



telergon
gorlan team

Switch - disconnectors
and changeover switches
general catalogue

AC DC



Presentation

TELERGON is one of the leading companies in the field of electromechanical engineering. It designs and manufactures components and provides solutions for the isolation and protection of low voltage electrical equipment and components for electrical switching.

The experience and knowledge gained over the years working together in a spirit of continuous innovation and the talent of its staff, are the values that provide a reputation for the products manufactured by TELERGON.

The various ranges of TELERGON switch - disconnectors and changeover switches have numerous applications in the field of electrical engineering, including series specifically designed for use in renewable energy generating plants.

www.telergon.com

This catalogue is printed on paper coming from sustainable certified forestry









Amperes 10 12 16 20 25 32 40 50 63 80 100 125 160 200 250 315 400 500 630 800 1000 1250 1600 1800 2000 2500 3150 4000 5000 6300

Switch - disconnectors

cam switches 1P 12P		T TB TF TP Information Pages 4-7 Product 8-23 Accessories 40-47 Diagrams 48-59
modular 3P 3P+N 6P 8P		ZBK Information Pages 60-61 Product 62-71
load-break 3P 3P+N		S5 Information Pages 72-73 Product 74-89
load-break 6P 8P		S5M Information Pages 72-73 Product 90-99
load-break 2P 3P 3P+N		S6 Information Pages 72-73 Product 100-103
enclosed load-break 3P 3P+N		CIS Information Pages 72-73 Product 104-115
for transformer secondary protection		IPT Information Pages 72-73 Product 116-117
with fuses 2P 3P 3P+N		M11 M21 Information Pages 118-119 Product 120-129
enclosed with fuses 3P 3P+N		CIF Information Pages 118-119 Product 130-139

Changeover switches

cam switches 1P 4P		T TB TF TP Information Pages 4-7 Product 24-39 Accessories 40-47 Diagrams 48-59
modular 3P 3P+N		ZBK Information Pages 60-61 Product 68-69
load-break in line 3P 3P+N		S5L Information Pages 140-141 Product 142-145
back to back 3P 3P+N		S5F Information Pages 140-141 Product 144-145 152-155
load-break compact 3P 3P+N		CCF CCP Information Pages 140-141 Product 146-151
load-break by-pass 3P 3P+N		S5B Information Pages 140-141 Product 156-165
enclosed load-break 3P 3P+N		CTR Information Pages 140-141 Product 166-179

Motorized unit Kit

for switch - disconnector
or changeover switch

	UM Information Pages 180-181 Product 182-185
---	---

DC switch - disconnectors

modular

	ZFV Information Pages 186-187 Product 188-189
---	--

load-break

	S5 DC Information Pages 186-187 Product 190-201
---	--

load-break
multi-string or 1500 Vdc

	S5M DC Information Pages 186-187 Product 202-217
---	---

load-break

	S6 DC Information Pages 186-187 Product 218-225
---	--

load-break
1500 Vdc

	S6N DC Information Pages 186-187 Product 226-227
---	---

Pages	Reference-page index 228-231	General information 232-233
-------	------------------------------	-----------------------------

Cam switches and changeover switches

series
T|TB|TF|TP

Cam switches available in different construction models over a wide current range with a large variety of accessories.

According to:
IEC/EN 60947-3
UL508 - CAN/CSA C22.2 N° 14
RoHS

Testing and approvals:



Cam switches are manufactured in different series under strict quality controls to provide a reliable product that meets the most demanding requirements.

They consist of chambers, each containing up to two double break contacts of positive opening. These contacts silver alloy plated providing a long electromechanical life.

In sizes 0 - 1 and 2, the terminals are equipped with captive clamp screws to facilitate installation work, and all the connections themselves are covered to provide an IP20 protection rating.

The different configurations of contacts available provide flexible, faster and safer solutions for several electrical operations at a highly competitive cost.

Range coding:

Standard products

They are listed in this section and are encoded according to the 16-digit bar logic explained below. This descriptive method will be used on all pages in the cam switches range for your convenience and better understanding.

Special products

They are made according to customer specifications or to comply with a diagram or special scheme. In these cases, the code is formed by the corresponding series (T-TB-TF-TP), the amperage and an order number assigned to the scheme (see blank diagrams form on page 49).

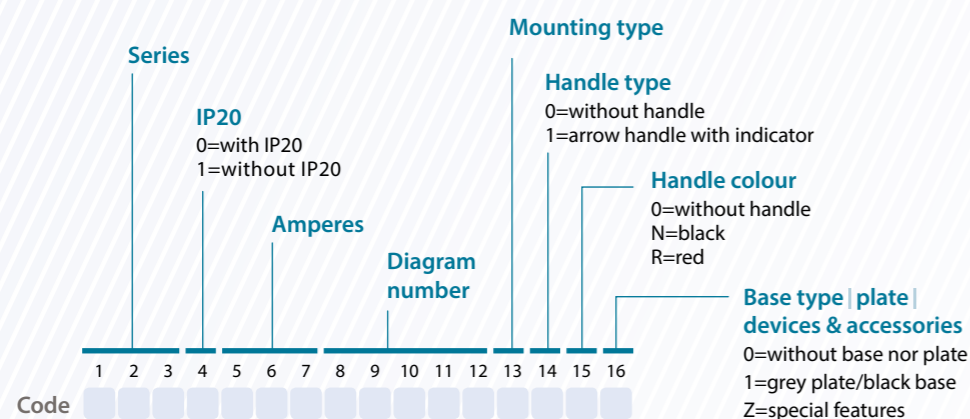

Example **T-0010000012E1N1**

T series | 100 amperes | 012 diagram | E fixing |
Standard handle | Black colour |
Grey plate/black base |

series
T



Wide range of sizes and ratings.
Supplied with IP20 removable terminals protection on sizes 0 - 1 - 2.
Wide range of devices and accessories.

series
TB



Side access to all terminal screws (up and down).
Two different bodies depending on mounting type: door or base mounting.
Wide range of devices and accessories.

series
TF



Square body, smooth sides, axial access to terminal screws.
Two different bodies depending on mounting type: door or base mounting.
Wide range of devices and accessories.

series
TP



Reduce-sized body. Door mounting only.
Wide range of devices and accessories.

series | type
TIP



> Cam switch in plastic enclosure for gland entry.
> From 12 up to 40 A.
> Padlockable handle under request.

series | type
T-TFIR



> Cam switch in plastic enclosure for gland entry.
> From 25 up to 100 A.
> Padlockable handle under request.

series | type
T-TBIA-C



> Cam switch in metal enclosure of cast aluminium
A From 12 up to 63 A.
> In sheet steel enclosure
C From 100 A upwards.
> Gland entry.
> Several enclosure sizes.
> Padlockable handle under request.

series | type
T-TBIF-L



> Cam switch in metal enclosure of cast aluminium
L with fuse holders, from 16 up to 63A.
> In sheet steel enclosure
F with fuse holders, from 100A upwards.
> Gland entry.
> Several enclosure sizes.
> Fuses not included.
> Padlockable handle under request.

>> Ask for more information about these applications with enclosure.

TP | T | TB | TF

Door mounting

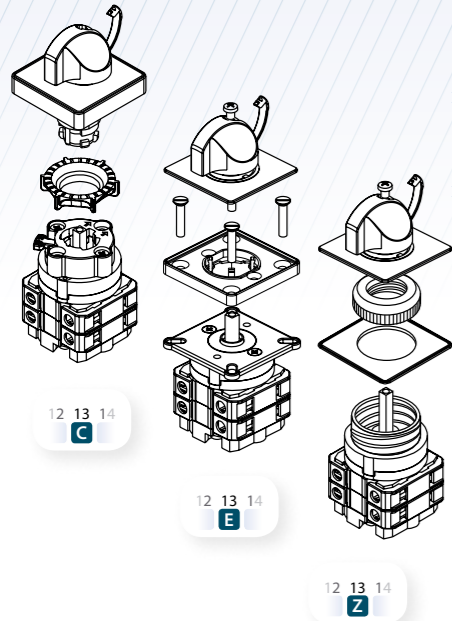

Fixing with screws | E type

For T - TB - TF - TP series

- > Frontal fixing plate for 4 screws, reversible mounting plate in T series (except T175 & size 3).
- > Door mounting with arrow handle, indicating plate, escutcheon and fixing plate IP65.

Central quick fixing $\varnothing 22$ | C type

For T - TB - TF series

- > Door mounting for $\varnothing 22$ mm available for sizes 0 and 1.
- > For arrow handle with indicator or padlockable handle.
- > Maximum number of chambers supported
Size 0 = 6
Size 1 = 4

Central fixing with metal nut $\varnothing 22$ | Z type

For T - TF series

- > Door mounting for metal nut $\varnothing 22$ mm available for sizes 0 and 1.
(also $\varnothing 30$ mm under request).

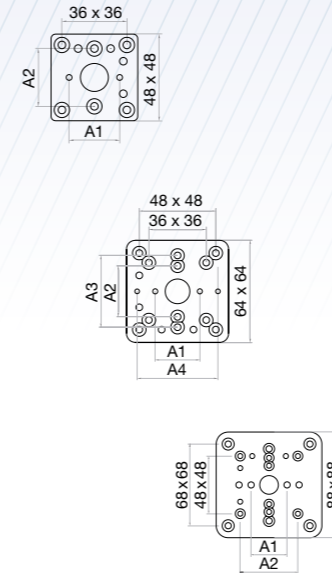

Size	Models		
0	A1 = 28 mm	A2 = 32 mm	M
	A1 = 30 mm	A2 = 34 mm	N
	A1 = 35 mm	A2 = 38 mm	O
1	A1 = 28 mm A4 = 46 mm	A2 = 32 mm	M
	A1 = 33 mm A3 = 47 mm	A2 = 30 mm A4 = 50 mm	N
	A1 = 32 mm A3 = 45 mm	A2 = 32 mm A4 = 45 mm	P
2	A1 = 38 mm	A3 = 40 mm	M
	A1 = 30 mm	A2 = 50 mm	P

Multi-distance fixing plates with screws

For T - TB - TF series

- > Multidrill plates for different fixing distances.
- > Fixing with two screws for mounting without base nor indicating plate.
- > Available for sizes 0 - 1 - 2.
(size 0 also supports multi-fixing plate size 1).

Base mounting

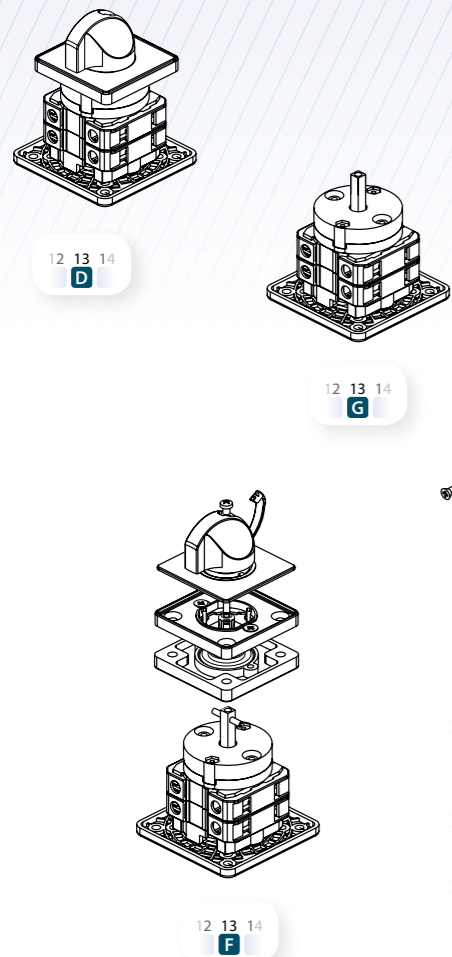

Base mounting by screws with direct handle | D type

For T series

- > Rear fixing plate for 4 screws, reversible mounting plate in T series (except size 3).

Base mounting by screws without plate and handle | G type

For TB - TF series

- > Fixed rear support plate as standard.
- > Serie TB for 4 screws.
- > Serie TF for two screws (also DIN rail).

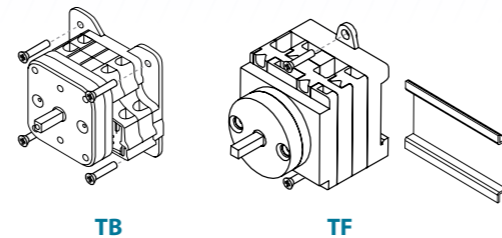
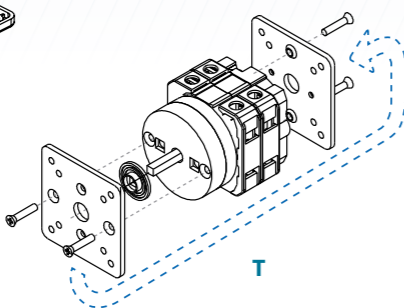

Base mounting with clutch device and door handle | F type

For T - TB - TF series

- > Rear fixing plate for 4 screws in T - TB series or two screws and DIN rail in TF series.
- > With clutch device and door lock, according to series and sizes.
- > The clutch device (D501) for size 0, if it is combined with other accessory, must be size 1.
- > The clutch device (D501) and shaft extension are supplied separately (as accessories) or incorporated with the cam switch (size 3 is always incorporated with the cam switch).
- > Specify useful depth of the space available when ordering.

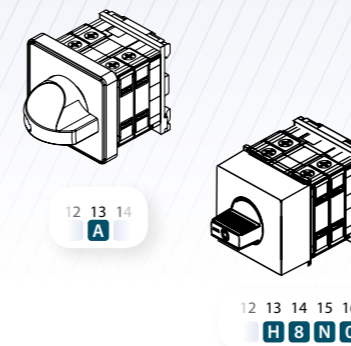

DIN rail mounting with direct handle | A type

For T series

- > Rear fixing support (D904) for T series sizes 0 and 1.
- > DIN rail is included in TF series.

DIN rail mounting with modular handle | H type

For TF series

- > Rear fixing support and modular handle tape (D905) for T - TF series size 0.

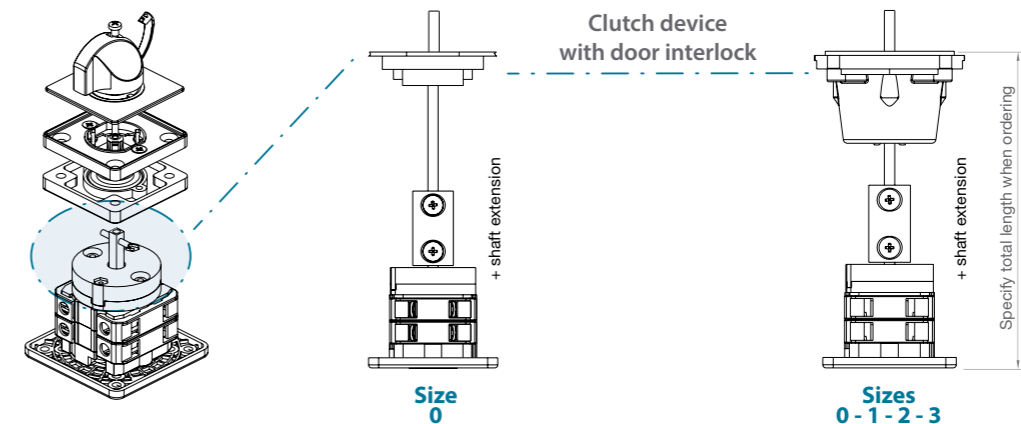

TP|T|TB|TF Door mounting switch

1P up to 12P

Size 0
A 10|12|16|20|25|32



Technical information



According to IEC/EN 60947-3
UL508 - CAN/CSA C22.2 N° 14

According to IEC 60947-3		TP10	T12	T20	TB20	TB25	TB32	TF12	TF16	TF25	
Rated thermal current	I _{th}	A	12	16	25	20	25	20	25	32	
Rated insulation voltage	U _i	V	500	500	500	500	500	690	690	690	
Rated impulse withstand voltage	U _{imp}	kV	4	6	6	6	6	6	6	6	
AC rated operational current	I _e	Ue 415V AC13A	A	10	-	-	-	-	-	-	-
		Ue 415V AC21A	A	12	16	25	20	25	32	20	25
		Ue 415V AC22A	A	12	16	25	20	25	32	20	25
		Ue 415V AC23A	A	10	-	-	20	25	32	-	-
		Ue 500V AC21A	A	-	16	20	20	25	32	-	-
		Ue 500V AC22A	A	-	16	20	20	25	32	-	-
		Ue 500V AC23A	A	-	-	-	16	20	25	-	-
		Ue 690V AC21A	A	-	-	-	-	-	16	25	32
		Ue 690V AC22A	A	-	-	-	-	-	16	25	25
		Ue 690V AC23A	A	-	-	-	-	-	-	16	25
AC rated operational power (Rated operational frequency 50/60 Hz)	P _e	3x240V AC23A	kW	3	4	4	5,4	6,7	8,6	4	5,5
		3x240V AC3	kW	2,2	3	4	3,7	4,6	5,9	4	5,5
		3x240V AC4	kW	-	1,1	1,5	2,9	3,7	4,6	1,5	2,2
		1x240V AC3	kW	-	1,5	2,2	2,1	2,7	4	2,2	3
		1x240V AC4	kW	-	0,37	0,55	1	1,25	1,5	0,55	0,75
		3x415V AC23A	kW	4,6	5,5	7,5	9,3	11,7	15	7,5	11
		3x415V AC3	kW	4	4	5,5	6,4	8	10,3	5,5	7,5
		3x415V AC4	kW	-	2,2	3	3,1	3,8	5,5	3	4
		1x400V AC3	kW	-	2,2	3	3,6	4,5	5,7	3	4
		1x400V AC4	kW	-	0,75	1,1	1,7	2,2	3	1,1	1,5
		3x500V AC23A	kW	-	5,5	7,5	9	11	14	7,5	11
		3x500V AC3	kW	-	4	7,5	7,8	9,7	12,5	7,5	11
3x690V AC23A	kW	-	-	-	-	-	-	7,5	11		
3x690V AC3	kW	-	-	-	-	-	-	5,5	7,5		
3x690V AC4	kW	-	-	-	-	-	-	3	4		
Rated conditional short-circuit current		kA	5	10	10	5	5	5	5	5	
Rated maximum current	gL-gG	A	16	25	25	35	35	20	25	32	
Rated breaking capacity	400V; cos φ=0,45	A	80	80	100	160	200	256	100	160	
Rated short-time withstand current (1 sec)		A	100	240	400	240	400	500	400	500	
Mechanical durability (thousand of operations)			2000	1000	1000	1000	1000	1000	1000	1000	
Rigid copper conductor		mm ²	2x4	2x4	2x4	1x10 2x6	1x10 2x6	1x10 2x6	1x10	1x10	
Flexible copper conductor		mm ²	2x2,5	2x2,5	2x2,5	1x6 2x4	1x6 2x4	1x6 2x4	1x6	1x6	
According to UL508 - CAN / CSA C22.2 N° 14			T12	T20				TF12	TF16	TF25	
Rated thermal current	I _{th}	A	-	12	20	-	-	16	20	25	
General use rating		Vac	-	300	300	-	-	600	600	600	
AC rated operational power	3x240V	HP	-	2	5	-	-	2	5	7,5	
	3x480V	HP	-	-	-	-	-	5	10	12	
	3x600V	HP	-	-	-	-	-	5	10	15	

Normal service conditions:

Ambient air temperature (°C): -5°...+40°. Maximum altitude: 2.000 m. Maximum humidity: 90%. Pollution degree: 3 (standard for industrial applications). Rated frequency at AC utilization categories: 50/60 Hz.

Rated duties at utilization categories AC21A, AC22A and AC23A: Continuing (8 hours); uninterrupted.

Rated duties at utilization categories AC3 and AC4: Intermittent; temporary.



Series | Amp

- TP-0010
- T-00012
- T-00020
- TB-0020
- TB-0025
- TB-0032
- TF-0012
- TF-0016
- TF-0025

Diagram

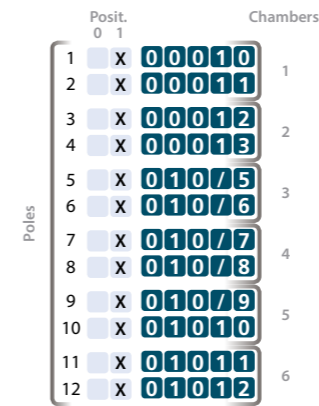

Type

Model or fixing

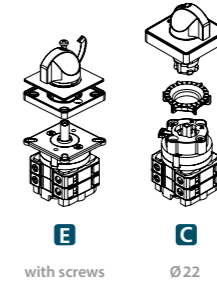
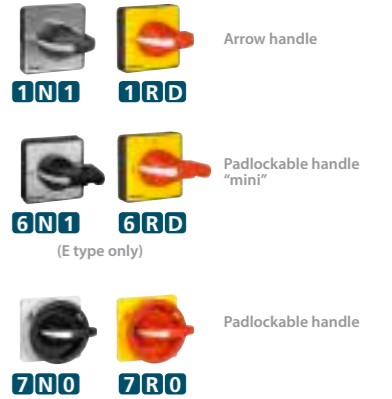
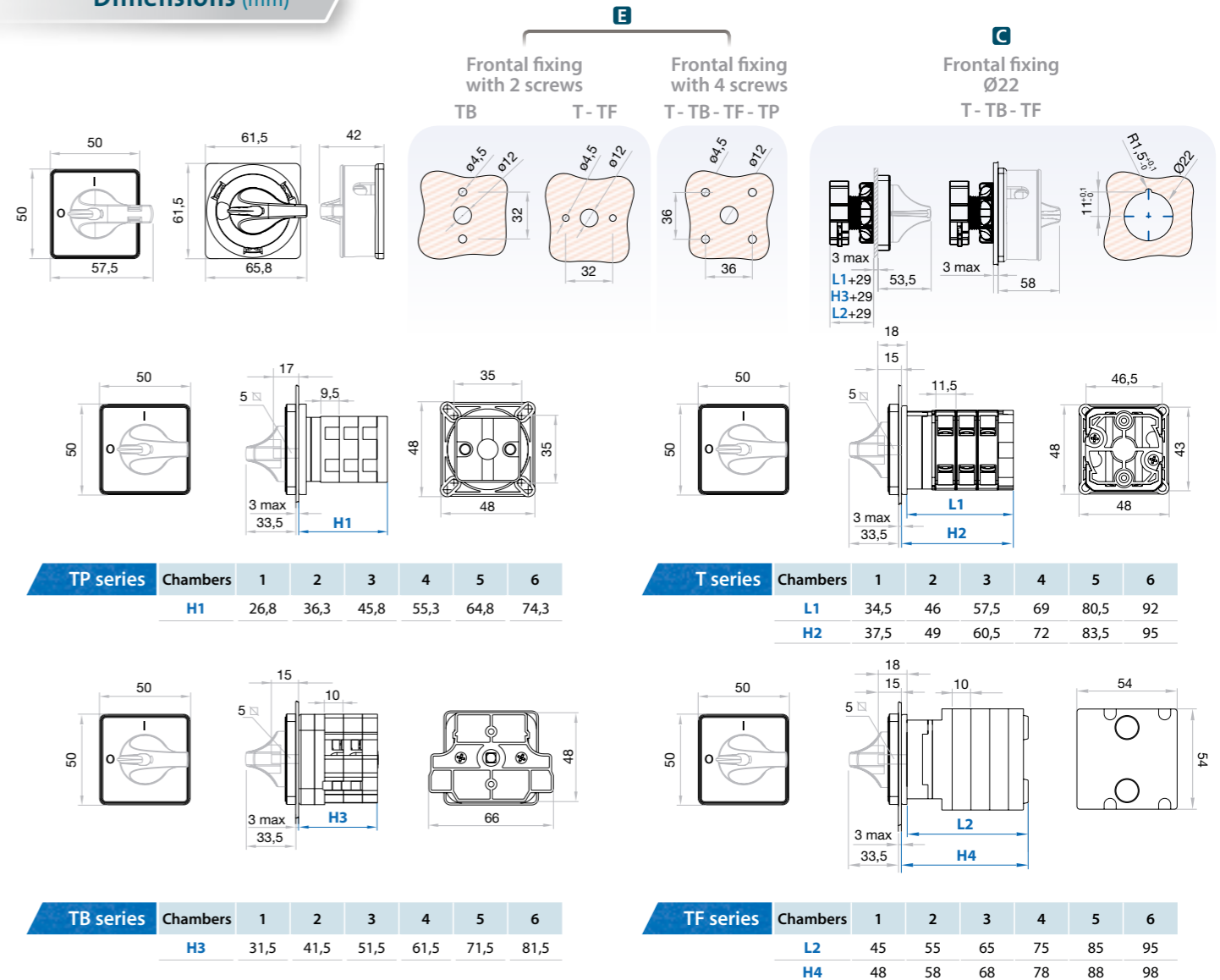

Plate and handle



Dimensions (mm)



T|TB|TF Base mounting switch with clutch device 1P up to 12P

Size 0
A 12|16|20|25|32

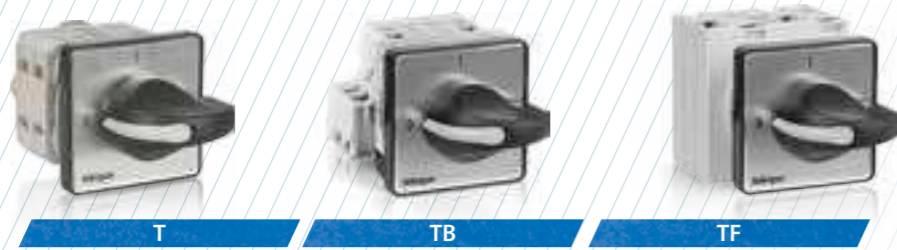

Technical information



According to IEC/EN 60947-3
UL508 - CAN/CSA C22.2 N° 14

According to IEC 60947-3		T12	T20	TB20	TB25	TB32	TF12	TF16	TF25		
Rated thermal current	I _{th}	A	16	25	20	25	20	25	32		
Rated insulation voltage	U _i	V	500	500	500	500	690	690	690		
Rated impulse withstand voltage	U _{imp}	kV	6	6	6	6	6	6	6		
AC rated operational current	I _e	Ue 415V AC21A	A	16	25	20	25	32	20	25	32
		Ue 415V AC22A	A	16	25	20	25	32	20	25	32
		Ue 415V AC23A	A	-	-	20	25	32	-	-	-
		Ue 500V AC21A	A	16	20	20	25	32	-	-	-
		Ue 500V AC22A	A	16	20	20	25	32	-	-	-
		Ue 500V AC23A	A	-	-	16	20	25	-	-	-
		Ue 690V AC21A	A	-	-	-	-	-	16	25	32
		Ue 690V AC22A	A	-	-	-	-	-	16	25	25
		3x240V AC23A	kW	4	4	5,4	6,7	8,6	4	5,5	7,5
		3x240V AC3	kW	3	4	3,7	4,6	5,9	4	5,5	5,5
AC rated operational power (Rated operational frequency 50/60 Hz)	P _e	3x240V AC4	kW	1,1	1,5	2,9	3,7	4,6	1,5	2,2	3
		1x240V AC3	kW	1,5	2,2	2,1	2,7	4	2,2	3	4
		1x240V AC4	kW	0,37	0,55	1	1,25	1,5	0,55	0,75	1,1
		3x415V AC23A	kW	5,5	7,5	9,3	11,7	15	7,5	11	11
		3x415V AC3	kW	4	5,5	6,4	8	10,3	5,5	7,5	7,5
		3x415V AC4	kW	2,2	3	3,1	3,8	5,5	3	4	5,5
		1x400V AC3	kW	2,2	3	3,6	4,5	5,7	3	4	5,5
		1x400V AC4	kW	0,75	1,1	1,7	2,2	3	1,1	1,5	1,5
		3x500V AC23A	kW	5,5	7,5	9	11	14	7,5	11	11
		3x500V AC4	kW	4	7,5	7,8	9,7	12,5	7,5	7,5	11
Rated conditional short-circuit current	kA	T12	10	10	5	5	5	5	5		
		T20	10	10	5	5	5	5	5		
		TF12	10	10	5	5	5	5	5		
Rated maximum current	gL-gG	A	25	25	35	35	35	20	25	32	
Rated breaking capacity	400V; cos φ=0,45	A	80	100	160	200	256	100	160	200	
Rated short-time withstand current (1 sec)	A	240	400	240	400	500	350	400	500		
Mechanical durability (thousand of operations)		1000	1000	1000	1000	1000	1000	1000	1000		
Rigid copper conductor	mm ²	2x4	2x4	1x10 2x6	1x10 2x6	1x10 2x6	1x10	1x10	1x10		
Flexible copper conductor	mm ²	2x2,5	2x2,5	1x6 2x4	1x6 2x4	1x6 2x4	1x6	1x6	1x6		
According to UL508 - CAN / CSA C22.2 N° 14											
Rated thermal current	I _{th}	A	12	20	-	-	16	20	25		
General use rating	Vac	300	300	-	-	-	600	600	600		
AC rated operational power	HP	3x240V	2	5	-	-	2	5	7,5		
		3x480V	-	-	-	-	5	10	12		
		3x600V	-	-	-	-	5	10	15		

Normal service conditions:

Ambient air temperature (°C): -5°...+40°. Maximum altitude: 2.000 m. Maximum humidity: 90%. Pollution degree: 3 (standard for industrial applications). Rated frequency at AC utilization categories: 50/60 Hz.
Rated duties at utilization categories AC21A, AC22A and AC23A: Continuing (8 hours); uninterrupted.
Rated duties at utilization categories AC3 and AC4: Intermittent; temporary.

Series | Amp

- T-000112
- T-00020
- TB-0020
- TB-0025
- TB-0032
- TF-0012
- TF-0016
- TF-0025



Diagram

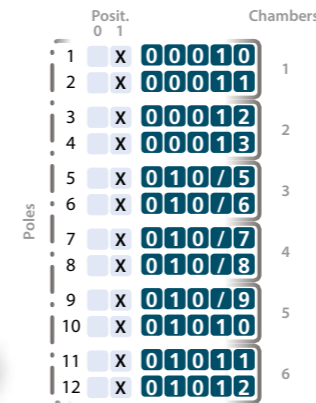

Type



Plate and handle

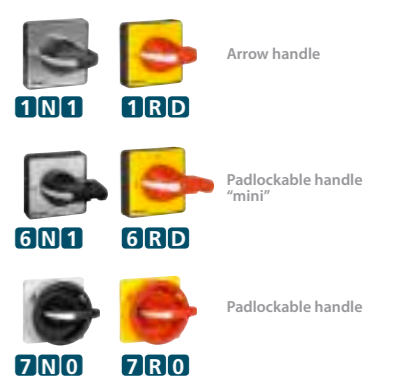

Dimensions (mm)

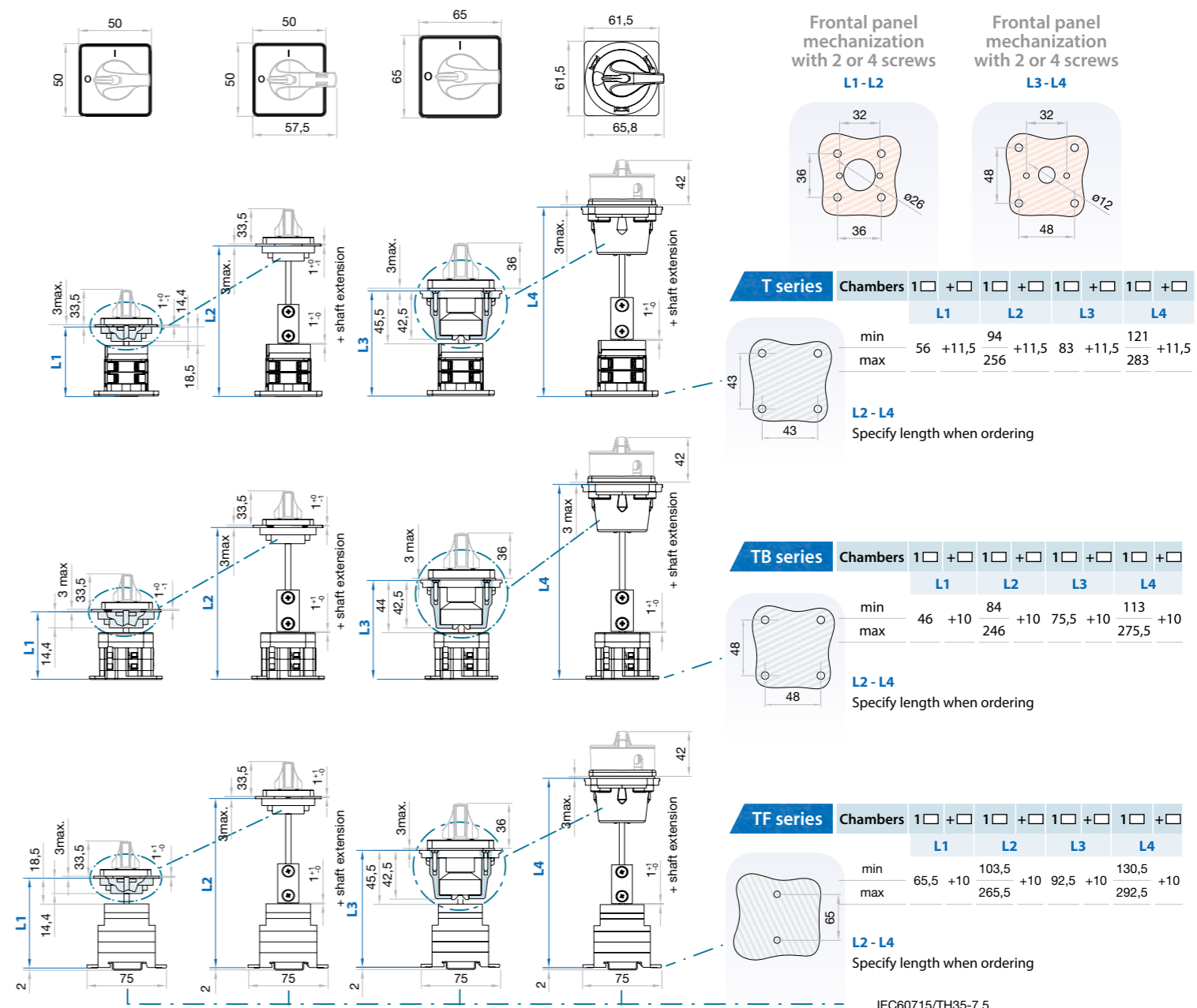

IEC60715/TH35-7,5
DIN46277

For more information of these series; accessories see pages 40-47 | diagrams see pages 50-59

T Door mounting switch

1P up to 12P

Size 1
A 16|25|32|40



Technical information



According to IEC/EN 60947-3
UL508 - CAN/CSA C22.2 N° 14

According to IEC 60947-3			T16	T25	T32	T40	
Rated thermal current	Ith	A	25	32	40	50	
Rated insulation voltage	Ui	V	690	690	690	690	
Rated impulse withstand voltage	Uimp	kV	6	6	8	8	
AC rated operational current	Ue 415V	AC21A	A	25	32	40	50
		AC22A	A	25	32	40	50
	Ue 690V	AC21A	A	25	32	40	50
		AC22A	A	25	25	40	40
	3x240V	AC23A	kW	5,5	7,5	11	15
	3x240V	AC3	kW	5,5	5,5	7,5	11
	3x240V	AC4	kW	2,2	3	4	4
	1x240V	AC3	kW	3	4	5,5	5,5
	1x240V	AC4	kW	0,75	1,1	1,5	2,2
	3x415V	AC23A	kW	11	11	15	18,5
AC rated operational power (Rated operational frequency 50/60 Hz)	3x415V	AC3	kW	7,5	7,5	11	15
		AC4	kW	4	5,5	5,5	7,5
	1x400V	AC3	kW	4	5,5	7,5	7,5
		AC4	kW	1,5	1,5	2,2	3
	3x500V	AC23A	kW	11	11	15	18,5
	3x500V	AC3	kW	7,5	11	11	15
	3x500V	AC4	kW	4	5,5	5,5	7,5
	3x690V	AC23A	kW	11	15	18,5	30
	3x690V	AC3	kW	7,5	11	15	22
	3x690V	AC4	kW	4	5,5	5,5	7,5
Rated conditional short-circuit current		kA	10	10	10	10	
Rated maximum current	gL-gG	A	32	32	50	50	
Rated breaking capacity	400V; cos φ=0,45	A	160	200	256	320	
Rated short-time withstand current (1 sec)		A	500	650	725	800	
Mechanical durability (thousand of operations)			1000	1000	1000	1000	
Rigid copper conductor		mm ²	2x6	2x6	2x10	2x10	
Flexible copper conductor		mm ²	2x4	2x4	2x6	2x6	
According to UL508 - CAN / CSA C22.2 N° 14			T16	T25	T32	T40	
Rated thermal current	Ith	A	16	25	32	40	
General use rating		Vac	600	600	600	600	
AC rated operational power	3x240V	HP	5,3	7,5	10	15	
	3x480V	HP	15	15	20	25	
	3x600V	HP	20	20	25	30	

Normal service conditions:
Ambient air temperature (°C): -5°...+40°. Maximum altitude: 2.000 m. Maximum humidity: 90%. Pollution degree: 3 (standard for industrial applications). Rated frequency at AC utilization categories: 50/60 Hz.
Rated duties at utilization categories AC21A, AC22A and AC23A: Continuing (8 hours); uninterrupted.
Rated duties at utilization categories AC3 and AC4: Intermittent; temporary.

Series | Amp
T-000016
T-000025
T-000032
T-000040

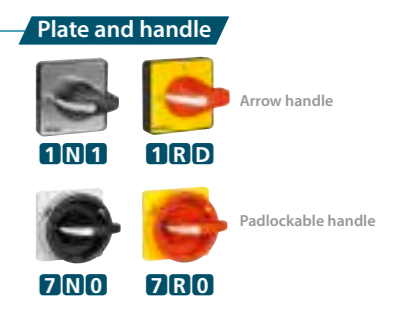
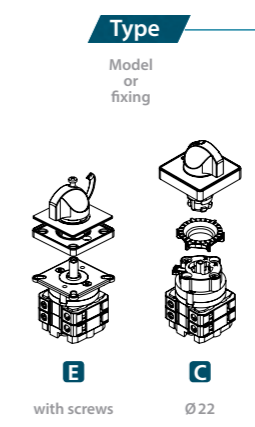
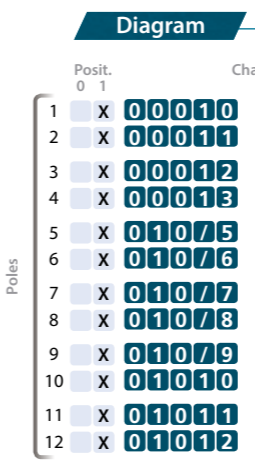

Dimensions (mm)

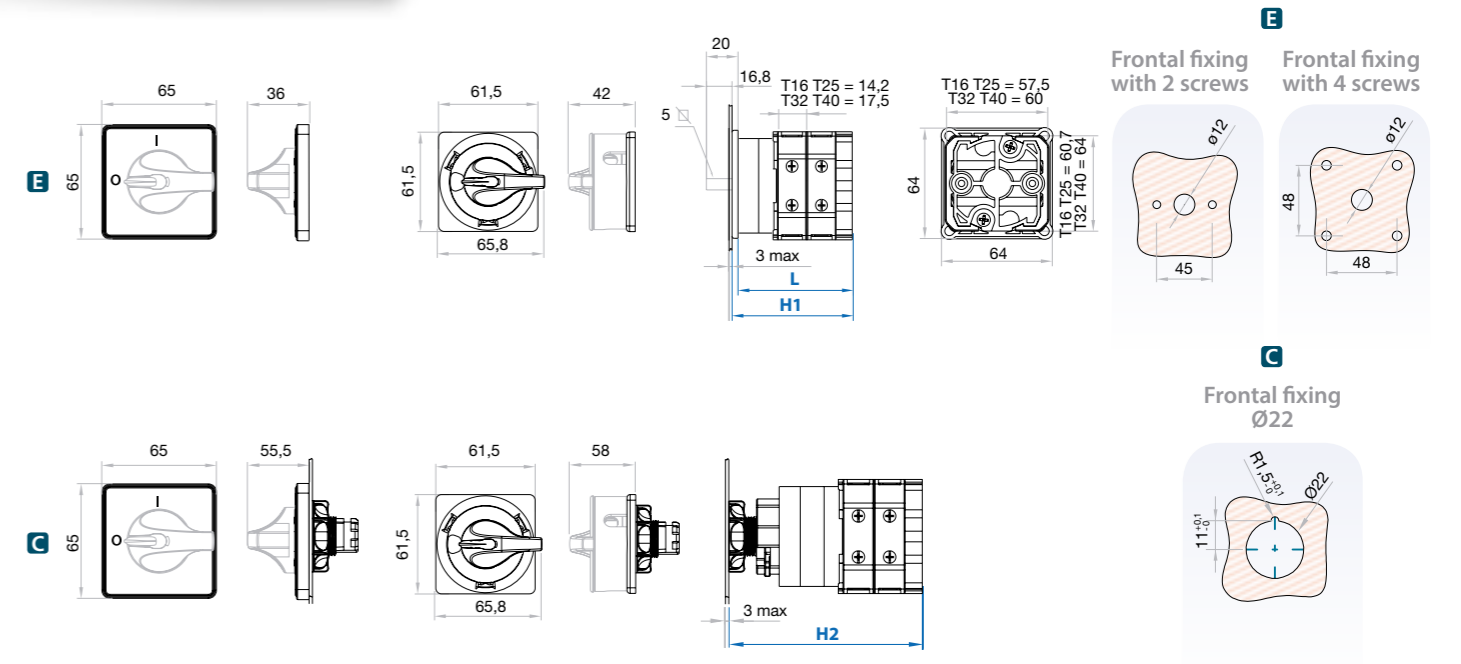

T series	Chambers	1□	2□	3□	4□	5□	6□
T16 T25	L	46,4	60,6	74,8	89	103,2	117,4
	H1	49,6	63,8	78	92,2	106,4	120,6
	H2	75,5	89,5	103,7	117,9	132,1	146,3
T32 T40	L	49,8	67,3	84,8	102,3	119,8	137,3
	H1	53	70,5	88	105,5	123	140,5
	H2	78,8	96,3	113,8	131,3	148,8	166,3

T Base mounting switch with clutch device 1P up to 12P

Size 1
A 16|25|32|40



T

Technical information



According to IEC/EN 60947-3
UL508 - CAN/CSA C22.2 N° 14

According to IEC 60947-3			T16	T25	T32	T40	
Rated thermal current	Ith	A	25	32	40	50	
Rated insulation voltage	Ui	V	690	690	690	690	
Rated impulse withstand voltage	Uimp	kV	6	6	8	8	
AC rated operational current	Ue 415V	AC21A	A	25	32	40	50
		AC22A	A	25	32	40	50
	Ue 690V	AC21A	A	25	32	40	50
		AC22A	A	25	25	40	40
	3x240V	AC23A	kW	5,5	7,5	11	15
		AC3	kW	5,5	5,5	7,5	11
		AC4	kW	2,2	3	4	4
		AC3	kW	3	4	5,5	5,5
		AC4	kW	0,75	1,1	1,5	2,2
		AC23A	kW	11	11	15	18,5
AC rated operational power (Rated operational frequency 50/60 Hz)	3x415V	AC3	kW	7,5	7,5	11	15
		AC4	kW	4	5,5	5,5	7,5
	1x400V	AC3	kW	4	5,5	7,5	7,5
		AC4	kW	1,5	1,5	2,2	3
	3x500V	AC23A	kW	11	11	15	18,5
		AC3	kW	7,5	11	11	15
		AC4	kW	4	5,5	5,5	7,5
		AC23A	kW	11	15	18,5	30
		AC3	kW	7,5	11	15	22
		AC4	kW	4	5,5	5,5	7,5
Rated conditional short-circuit current		kA	10	10	10	10	
Rated maximum current	gL-gG	A	32	32	50	50	
Rated breaking capacity	400V; cos φ=0,45	A	160	200	256	320	
Rated short-time withstand current (1 sec)		A	500	650	725	800	
Mechanical durability (thousand of operations)			1000	1000	1000	1000	
Rigid copper conductor		mm ²	2x6	2x6	2x10	2x10	
Flexible copper conductor		mm ²	2x4	2x4	2x6	2x6	
According to UL508 - CAN / CSA C22.2 N° 14			T16	T25	T32	T40	
Rated thermal current	Ith	A	16	25	32	40	
General use rating		Vac	600	600	600	600	
AC rated operational power	3x240V	HP	5,3	7,5	10	15	
	3x480V	HP	15	15	20	25	
	3x600V	HP	20	20	25	30	

Normal service conditions:
Ambient air temperature (°C): -5°...+40°. Maximum altitude: 2.000 m. Maximum humidity: 90%. Pollution degree: 3 (standard for industrial applications). Rated frequency at AC utilization categories: 50/60 Hz.
Rated duties at utilization categories AC21A, AC22A and AC23A: Continuing (8 hours); uninterrupted.
Rated duties at utilization categories AC3 and AC4: Intermittent; temporary.

Series | Amp

T-000016
T-000025
T-000032
T-000040

Code 1 2 3 4 5 6 7 8 9 10 11 12 13 14 15 16

Diagram

Posit. 0 1	Chambers	Diagram
1	X	00010
2	X	00011
3	X	00012
4	X	00013
5	X	01075
6	X	01076
7	X	01077
8	X	01078
9	X	01079
10	X	01010
11	X	01011
12	X	01012

Type

Model or fixing

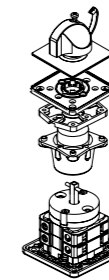
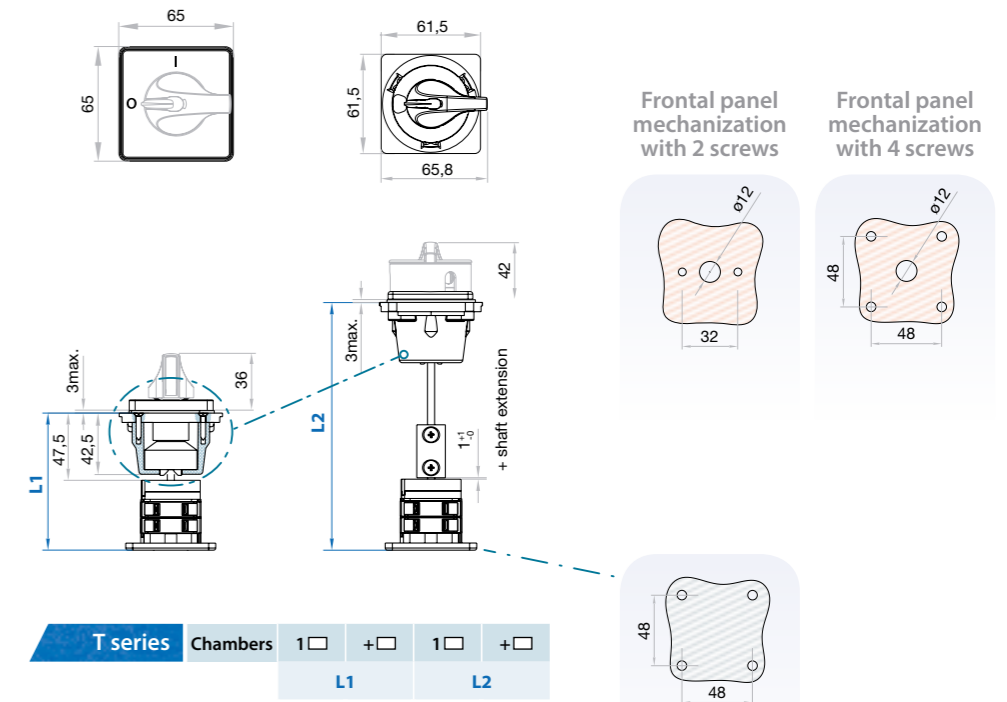

Plate and handle



Dimensions (mm)



T series	Chambers	1 □	+ □	1 □	+ □
		L1		L2	
T16 T25	min	97,1	+14,2	135,1	+14,2
	max			297,1	
T32 T40	min	100,5	+17,5	138,5	+17,5
	max			300,5	

L2
Specify length when ordering

T Door mounting switch

1P up to 12P

Size 2
A 50|63|80|100|125|175

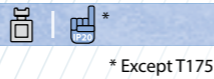

T

Technical information



According to IEC/EN 60947-3
UL508 - CAN/CSA C22.2 N° 14

According to IEC 60947-3			T50	T63	T80	T100	T125	T175	
Rated thermal current	Ith	A	63	80	80	125	125	200	
Rated insulation voltage	Ui	V	690	690	690	690	690	1000	
Rated impulse withstand voltage	Uimp	kV	8	8	8	8	8	8	
AC rated operational current	Ie	Ue 415V AC21A	A	63	80	80	125	125	200
		Ue 415V AC22A	A	63	80	80	115	115	200
		Ue 690V AC21A	A	63	80	80	115	115	175
		Ue 690V AC22A	A	63	63	63	100	100	160
		3x240V AC23A	kW	18,5	22	22	30	30	55
		3x240V AC3	kW	15	18,5	18,5	30	30	37
AC rated operational power (Rated operational frequency 50/60 Hz)	Pe	3x240V AC4	kW	5,5	7,5	7,5	11	11	15
		1x240V AC3	kW	7,5	11	11	15	15	18,5
		1x240V AC4	kW	3	3	3	4	4	5,5
		3x415V AC23A	kW	30	37	37	45	45	90
		3x415V AC3	kW	22	30	30	37	37	75
		3x415V AC4	kW	11	11	11	15	15	18,5
		1x400V AC3	kW	15	18,5	18,5	18,5	18,5	20
		1x400V AC4	kW	4	5,5	5,5	7,5	7,5	11
		3x500V AC23A	kW	30	37	37	55	55	110
		3x500V AC3	kW	22	30	30	45	45	75
		3x500V AC4	kW	11	11	11	15	15	18,5
		3x690V AC23A	kW	37	45	45	55	55	75
3x690V AC3	kW	37	45	45	45	45	55		
3x690V AC4	kW	11	11	11	15	15	18,5		
Rated conditional short-circuit current		kA	15	15	15	15	15	15 ⁽²⁾	
Rated maximum current	gL-gG	A	80	80	80	125	125	160	
Rated breaking capacity	400V; cos φ=0,45	A	504	504	504	640	640	1600	
Rated short-time withstand current (1 sec)		A	1600	1600	1600	2500	2500	3500	
Mechanical durability (thousand of operations)			1000	1000	1000	1000	1000	1000	
Rigid copper conductor		mm ²	16/25 ⁽¹⁾	16/25 ⁽¹⁾	16/25 ⁽¹⁾	35/50 ⁽¹⁾	35/50 ⁽¹⁾	95	
Flexible copper conductor		mm ²	10/16 ⁽¹⁾	10/16 ⁽¹⁾	10/16 ⁽¹⁾	16/35 ⁽¹⁾	16/35 ⁽¹⁾	95	
According to UL508 - CAN / CSA C22.2 N° 14			T50	T63	T80	T100	T125	T175	
Rated thermal current	Ith	A	63	63	63	100	100		
General use rating		Vac	600	600	600	600	600		
AC rated operational power	3x240V	HP	20	20	20	30	30	Certification in progress	
	3x480V	HP	40	40	40	50	50		
	3x600V	HP	40	40	40	50	50		

*⁽¹⁾ With terminals for connection

*⁽²⁾ Mounting without connection terminals or terminals + phase barriers DT-90025

Normal service conditions:

Ambient air temperature (°C): -5°...+40°. Maximum altitude: 2.000 m. Maximum humidity: 90%. Pollution degree: 3 (standard for industrial applications). Rated frequency at AC utilization categories: 50/60 Hz.

Rated duties at utilization categories AC21A, AC22A and AC23A: Continuing (8 hours); uninterrupted.

Rated duties at utilization categories AC3 and AC4: Intermittent; temporary.



Series | Amp

T-00050
T-00063
T-00080
T-00100
T-00125
T-00175

Diagram

Posit. 0 1	Chambers	Type
1 X	00010	1
2 X	00011	2
3 X	00012	3
4 X	00013	4
5 X	01075	5
6 X	01076	6
7 X	01077	7
8 X	01078	8
9 X	01079	9
10 X	01010	10
11 X	01011	11
12 X	01012	12

Type

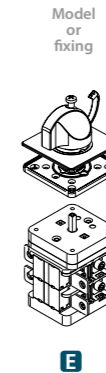
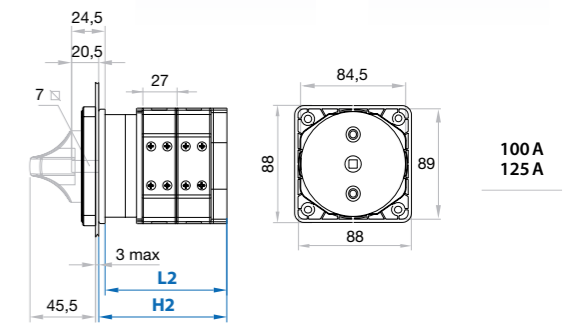
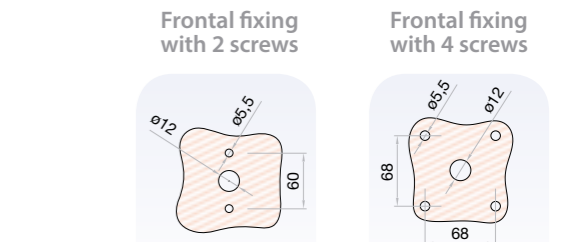
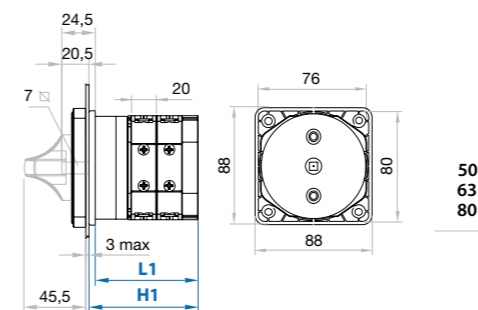
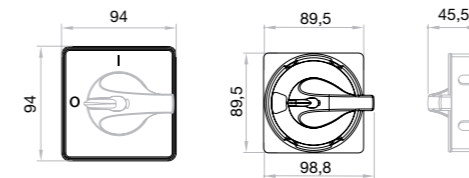

Plate and handle



Dimensions (mm)



T series	Chambers	1	2	3	4	5	6
T100	L2	67	94	121	148	175	202
T125	H2	71	98	125	152	179	206

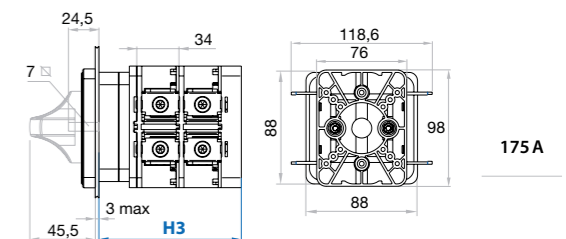

T series	Chambers	1	2	3	4	5	6
T175	H3	80,8	114,8	148,8	182,8	216,8	250,8

T series	Chambers	1	2	3	4	5	6
T50	L1	58,5	78,5	98,5	118,5	138,5	158,5
T63	H1	62,5	82,5	102,5	122,5	142,5	162,5
T80							

>> For more information of these series; accessories see pages 40-47 | diagrams see pages 50-59

T Base mounting switch with clutch device 1P up to 12P

Size 2
A 50|63|80|100|125|175



* Except T175



T

Technical information



According to IEC/EN 60947-3
UL508 - CAN/CSA C22.2 N° 14

According to IEC 60947-3		T50	T63	T80	T100	T125	T175		
Rated thermal current	Ith	A	63	80	80	125	125	200	
Rated insulation voltage	Ui	V	690	690	690	690	690	1000	
Rated impulse withstand voltage	Uimp	kV	8	8	8	8	8	8	
AC rated operational current	Ie	Ue 415V AC21A	A	63	80	80	125	125	200
		Ue 415V AC22A	A	63	80	80	115	115	200
		Ue 690V AC21A	A	63	80	80	115	115	175
		Ue 690V AC22A	A	63	63	63	100	100	160
		3x240V AC23A	kW	18,5	22	22	30	30	55
		3x240V AC3	kW	15	18,5	18,5	30	30	37
AC rated operational power (Rated operational frequency 50/60 Hz)	Pe	3x240V AC4	kW	5,5	7,5	7,5	11	11	15
		1x240V AC3	kW	7,5	11	11	15	15	18,5
		1x240V AC4	kW	3	3	3	4	4	5,5
		3x415V AC23A	kW	30	37	37	45	45	90
		3x415V AC3	kW	22	30	30	37	37	75
		3x415V AC4	kW	11	11	11	15	15	18,5
		1x400V AC3	kW	15	18,5	18,5	18,5	18,5	20
		1x400V AC4	kW	4	5,5	5,5	7,5	7,5	11
		3x500V AC23A	kW	30	37	37	55	55	110
		3x500V AC3	kW	22	30	30	45	45	75
		3x500V AC4	kW	11	11	11	15	15	18,5
		3x690V AC23A	kW	37	45	45	55	55	75
3x690V AC3	kW	37	45	45	45	45	55		
3x690V AC4	kW	11	11	11	15	15	18,5		
Rated conditional short-circuit current		kA	15	15	15	15	15	15 ⁽²⁾	
Rated maximum current	gL-gG	A	80	80	80	125	125	160	
Rated breaking capacity	400V; cos φ=0,45	A	504	504	504	640	640	1600	
Rated short-time withstand current (1 sec)		A	1600	1600	1600	2500	2500	3500	
Mechanical durability (thousand of operations)			1000	1000	1000	1000	1000	1000	
Rigid copper conductor		mm ²	16/25 ⁽¹⁾	16/25 ⁽¹⁾	16/25 ⁽¹⁾	35/50 ⁽¹⁾	35/50 ⁽¹⁾	95	
Flexible copper conductor		mm ²	10/16 ⁽¹⁾	10/16 ⁽¹⁾	10/16 ⁽¹⁾	16/35 ⁽¹⁾	16/35 ⁽¹⁾	95	
According to UL508 - CAN / CSA C22.2 N° 14		T50	T63	T80	T100	T125	T175		
Rated thermal current	Ith	A	63	63	63	100	100		
General use rating	Vac		600	600	600	600	600		
AC rated operational power	3x240V	HP	20	20	20	30	30	Certification in progress	
	3x480V	HP	40	40	40	50	50		
	3x600V	HP	40	40	40	50	50		

*⁽¹⁾ With terminals for connection

*⁽²⁾ Mounting without connection terminals or terminals + phase barriers DT-90025

Normal service conditions:

Ambient air temperature (°C): -5°...+40°. Maximum altitude: 2.000 m. Maximum humidity: 90%. Pollution degree: 3 (standard for industrial applications). Rated frequency at AC utilization categories: 50/60 Hz.

Rated duties at utilization categories AC21A, AC22A and AC23A: Continuing (8 hours); uninterrupted.

Rated duties at utilization categories AC3 and AC4: Intermittent; temporary.



Series | Amp

T-00050
T-00063
T-00080
T-00100
T-00125
T-00175

Diagram

Posit.	0	1	Chambers
1	X	00010	1
2	X	00011	2
3	X	00012	3
4	X	00013	4
5	X	01075	5
6	X	01076	6
7	X	01077	7
8	X	01078	8
9	X	01079	9
10	X	01010	10
11	X	01011	11
12	X	01012	12

Type

Model or fixing

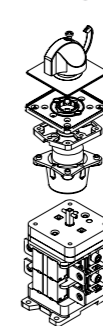
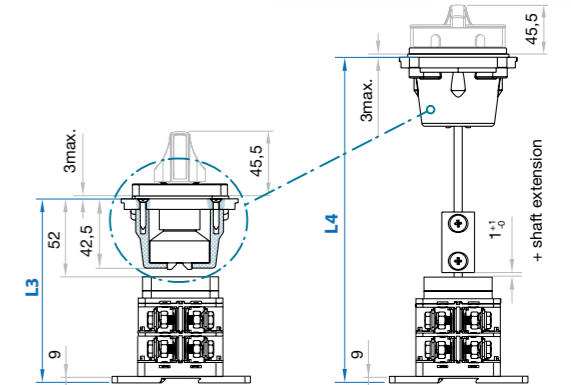
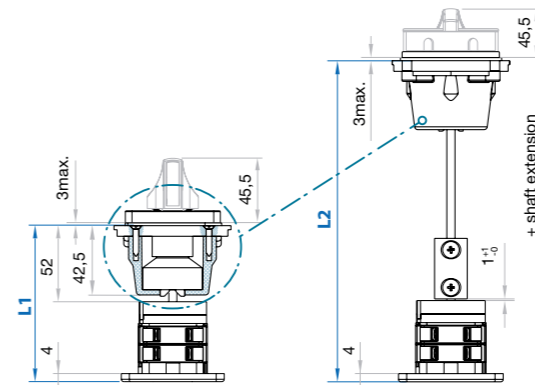
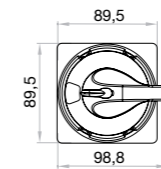
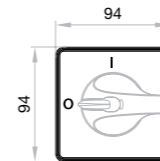

Plate and handle



Dimensions (mm)



T series	Chambers	1 □ + □	1 □ + □
		L1	L2
T50 T63 T80	min	114,5	152,5
	max	20	314,5
T100 T125	min	123	161
	max	27	323

T series	Chambers	1 □ + □	1 □ + □
		L3	L4
T175	min	141,8	179,8
	max	34	341,8

L2 Specify length when ordering

DIN rail support

Code DT-90421 (1 unit)

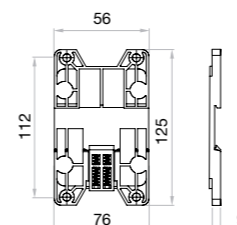

IEC60715/TH35-7,5
DIN46277

DIN rail or 4 screws included in the D or F fixing T175 types

The maximum number of chambers advisable is 3, for further conditions please consult

For more information of these series; accessories see pages 40-47 | diagrams see pages 50-59

T Door mounting switch

1P up to 12P

Size 3
A 200|250|315



Technical information



According to IEC/EN 60947-3
UL508 - CAN/CSA C22.2 N° 14

According to IEC 60947-3			T200	T250	T315	
Rated thermal current	Ith	A	200	250	315	
Rated insulation voltage	Ui	V	690	690	690	
Rated impulse withstand voltage	Uimp	kV	8	8	8	
AC rated operational current	Ie	Ue 415V AC21A	A	200	250	315
		Ue 415V AC22A	A	200	250	315
	Ue 690V AC21A	A	200	220	250	
	Ue 690V AC22A	A	200	200	200	
	3x240V AC23A	kW	55	67	75	
	3x240V AC3	kW	45	54	61	
	3x240V AC4	kW	15	18	20	
	1x240V AC3	kW	22	22	22	
	1x240V AC4	kW	7,5	9	10	
	3x415V AC23A	kW	90	115	130	
AC rated operational power (Rated operational frequency 50/60 Hz)	Pe	3x415V AC3	kW	75	95	108
		3x415V AC4	kW	22	28	31
	1x400V AC3	kW	37	47	53	
	1x400V AC4	kW	11	14	16	
	3x500V AC23A	kW	110	130	145	
	3x500V AC3	kW	90	106	118	
	3x500V AC4	kW	22	26	29	
	3x690V AC23A	kW	132	155	175	
	3x690V AC3	kW	110	129	145	
	3x690V AC4	kW	22	25	29	
Rated conditional short-circuit current		kA	25	15	15	
Rated maximum current	gL-gG	A	200	250	315	
Rated breaking capacity	400V; cos φ=0,45	A	1450	2000	2240	
Rated short-time withstand current (1 sec)		A	4400	4400	4400	
Mechanical durability (thousand of operations)			1000	1000	1000	
Rigid copper conductor		mm ²	95	120	185	
Flexible copper conductor		mm ²	95	120	185	
According to UL508 - CAN / CSA C22.2 N° 14			T200	T250	T315	
Rated thermal current	Ith	A	200	200	200	
General use rating		Vac	600	600	600	
AC rated operational power		HP	60	60	60	
	3x240V	HP	60	60	60	
	3x480V	HP	75	75	75	
	3x600V	HP	60	60	60	

Normal service conditions:
Ambient air temperature (°C): -5°...+40°. Maximum altitude: 2.000 m. Maximum humidity: 90%. Pollution degree: 3 (standard for industrial applications). Rated frequency at AC utilization categories: 50/60 Hz.
Rated duties at utilization categories AC21A, AC22A and AC23A: Continuing (8 hours); uninterrupted.
Rated duties at utilization categories AC3 and AC4: Intermittent; temporary.



Series | Amp

- T-00200
- T-00250
- T-00315

Diagram

Posit.	0	1	Chambers
1	X	00010	1
2	X	00011	1
3	X	00012	2
4	X	00013	2
5	X	01075	3
6	X	01076	3
7	X	01077	4
8	X	01078	4
9	X	01079	5
10	X	01010	5
11	X	01011	6
12	X	01012	6

Type

Model or fixing



Plate and handle

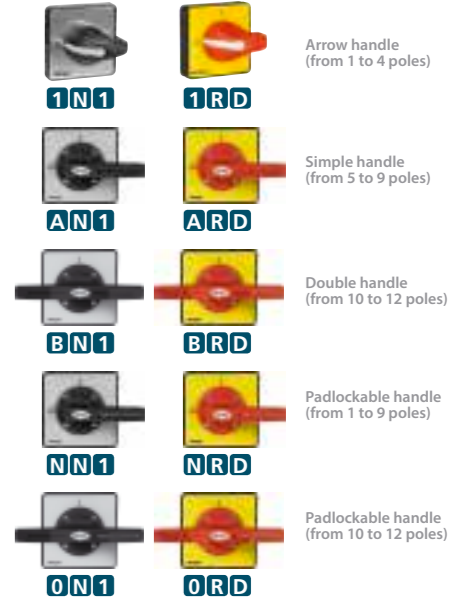

Dimensions (mm)

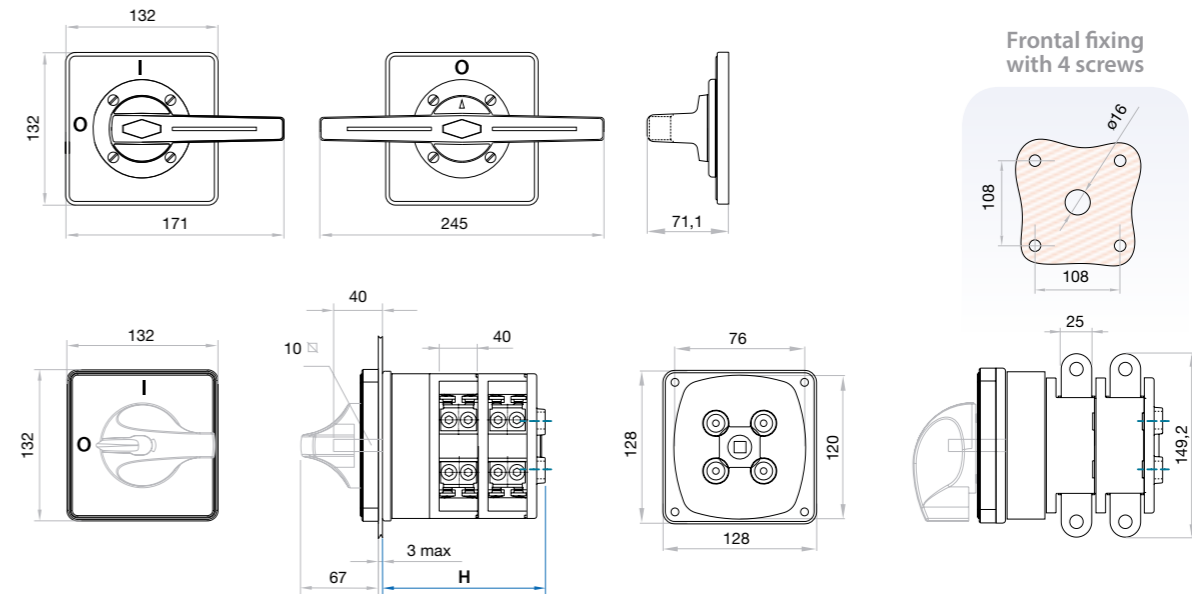

Terminal extensions according to UL.

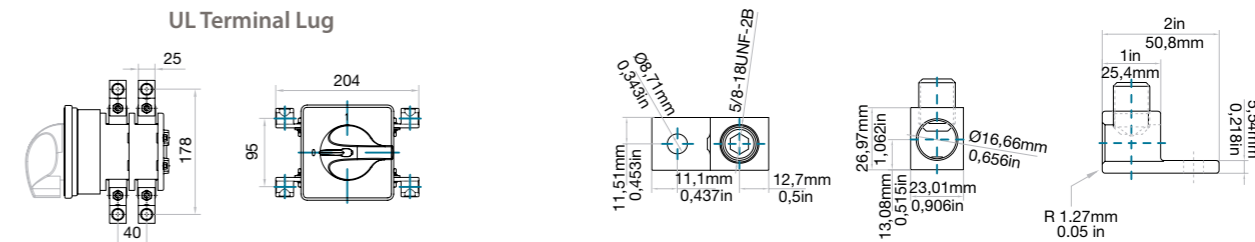

T series	Chambers	1	2	3	4	5	6		
T200	T250	T315	H	95	135	175	215	255	295

Wire size	Wires per lug	Wire type	kit reference
150 mm ² / 300 kcmil	1	Cu/Al	DS-TL01 (2 pieces)

Note: The hardware needed to complete the wiring is supplied as standard.

T Base mounting switch with clutch device

1P up to 12P



Size 3
A 200|250|315

Technical information



According to IEC/EN 60947-3
UL508 - CAN/CSA C22.2 N° 14

According to IEC 60947-3			T200	T250	T315	
Rated thermal current	Ith	A	200	250	315	
Rated insulation voltage	Ui	V	690	690	690	
Rated impulse withstand voltage	Uimp	kV	8	8	8	
AC rated operational current	Ie	Ue 415V AC21A	A	200	250	315
		Ue 415V AC22A	A	200	250	315
	Ue 690V AC21A	A	200	220	250	
	Ue 690V AC22A	A	200	200	200	
	3x240V AC23A	kW	55	67	75	
	3x240V AC3	kW	45	54	61	
	3x240V AC4	kW	15	18	20	
	1x240V AC3	kW	22	22	22	
	1x240V AC4	kW	7,5	9	10	
	3x415V AC23A	kW	90	115	130	
AC rated operational power (Rated operational frequency 50/60 Hz)	Pe	3x415V AC3	kW	75	95	108
		3x415V AC4	kW	22	28	31
	1x400V AC3	kW	37	47	53	
	1x400V AC4	kW	11	14	16	
	3x500V AC23A	kW	110	130	145	
	3x500V AC3	kW	90	106	118	
	3x500V AC4	kW	22	26	29	
	3x690V AC23A	kW	132	155	175	
	3x690V AC3	kW	110	129	145	
	3x690V AC4	kW	22	25	29	
Rated conditional short-circuit current		kA	25	15	15	
Rated maximum current	gL-gG	A	200	250	315	
Rated breaking capacity	400V; cos φ=0,45	A	1450	2000	2240	
Rated short-time withstand current (1 sec)		A	4400	4400	4400	
Mechanical durability (thousand of operations)			1000	1000	1000	
Rigid copper conductor		mm ²	95	120	185	
Flexible copper conductor		mm ²	95	120	185	
According to UL508 - CAN / CSA C22.2 N° 14			T200	T250	T315	
Rated thermal current	Ith	A	200	200	200	
General use rating		Vac	600	600	600	
AC rated operational power		HP	60	60	60	
	3x240V	HP	60	60	60	
	3x480V	HP	75	75	75	
	3x600V	HP	60	60	60	

Normal service conditions:

Ambient air temperature (°C): -5°...+40°. Maximum altitude: 2.000 m. Maximum humidity: 90%. Pollution degree: 3 (standard for industrial applications). Rated frequency at AC utilization categories: 50/60 Hz.
Rated duties at utilization categories AC21A, AC22A and AC23A: Continuing (8 hours); uninterrupted.
Rated duties at utilization categories AC3 and AC4: Intermittent; temporary.



Series | Amp

T-00200
T-00250
T-00315

Diagram

Posit. 0 1	Chambers	Type
1 X	00010	1
2 X	00011	2
3 X	00012	3
4 X	00013	4
5 X	01075	5
6 X	01076	6
7 X	01077	7
8 X	01078	8
9 X	01079	9
10 X	01010	10
11 X	01011	11
12 X	01012	12

Type

Model or fixing

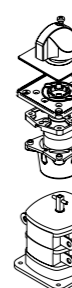
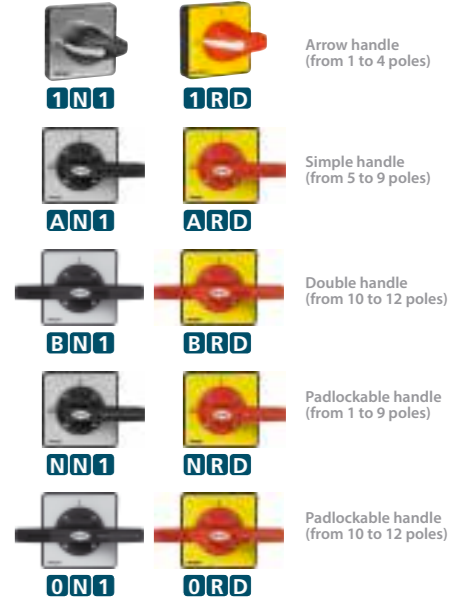
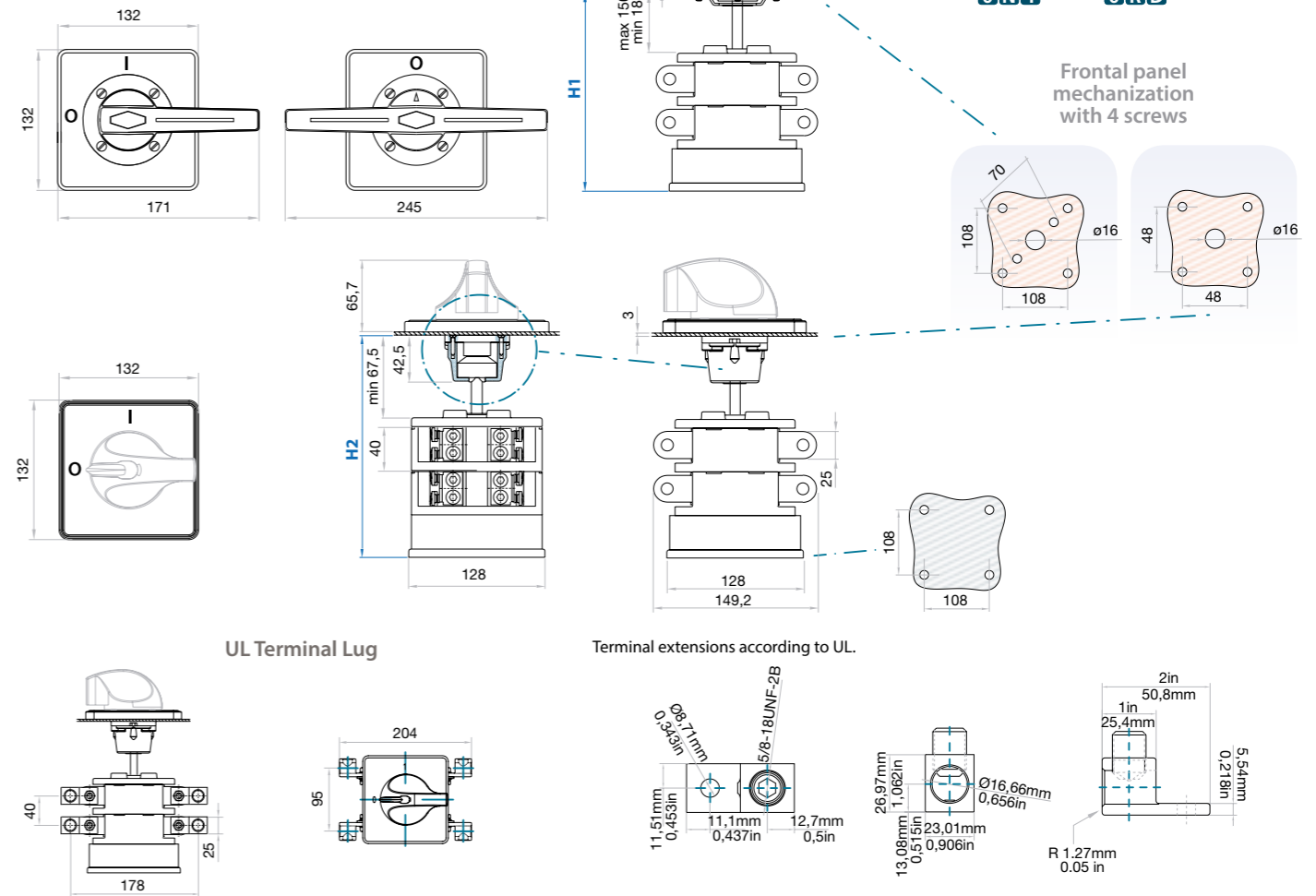

Plate and handle



Dimensions (mm)



UL Terminal Lug

Terminal extensions according to UL

T series	Chambers	1	2	3	4	5	6
T200 T250 T315	H1	139,3	179,3	219,3	259,3	299,3	339,3
	H2	162,5	202,5	242,5	282,5	322,5	362,5

Wire size	Wires per lug	Wire type	kit reference
150 mm ² / 300 kcmil	1	Cu/Al	DS-TL01 (2 pieces)

Note: The hardware needed to complete the wiring is supplied as standard.

H1-H2
Specify length when ordering

» For more information of these series; accessories see pages 40-47 | diagrams see pages 50-59

TP|T|TB|TF

Door mounting changeover

1P up to 4P

Size 0
A 10|12|16|20|25|32

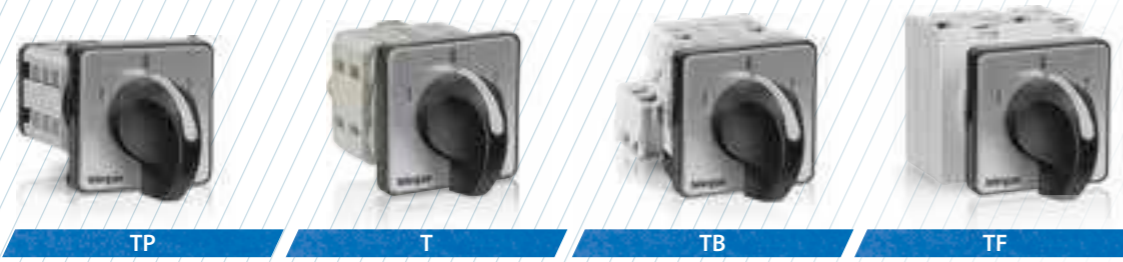

Technical information



According to IEC/EN 60947-3
UL508 - CAN/CSA C22.2 N° 14

According to IEC 60947-3		TP10	T12	T20	TB20	TB25	TB32	TF12	TF16	TF25	
Rated thermal current	I _{th}	A	12	16	25	20	25	32	20	25	
Rated insulation voltage	U _i	V	500	500	500	500	500	690	690	690	
Rated impulse withstand voltage	U _{imp}	kV	4	6	6	6	6	6	6	6	
AC rated operational current	I _e	Ue 415V AC13A	A	10	-	-	-	-	-	-	-
		Ue 415V AC21A	A	12	16	25	20	25	32	20	25
		Ue 415V AC22A	A	12	16	25	20	25	32	20	25
		Ue 415V AC23A	A	10	-	-	20	25	32	-	-
		Ue 500V AC21A	A	-	16	20	20	25	32	-	-
		Ue 500V AC22A	A	-	16	20	20	25	32	-	-
		Ue 500V AC23A	A	-	-	-	16	20	25	-	-
		Ue 690V AC21A	A	-	-	-	-	-	16	25	32
		Ue 690V AC22A	A	-	-	-	-	-	16	25	25
		Ue 690V AC23A	A	-	-	-	-	-	16	25	25
AC rated operational power (Rated operational frequency 50/60 Hz)	P _e	3x240V AC23A	kW	3	4	4	5,4	6,7	8,6	4	5,5
		3x240V AC3	kW	2,2	3	4	3,7	4,6	5,9	4	5,5
		3x240V AC4	kW	-	1,1	1,5	2,9	3,7	4,6	1,5	2,2
		1x240V AC3	kW	-	1,5	2,2	2,1	2,7	4	2,2	3
		1x240V AC4	kW	-	0,37	0,55	1	1,25	1,5	0,55	0,75
		3x415V AC23A	kW	4,6	5,5	7,5	9,3	11,7	15	7,5	11
		3x415V AC3	kW	4	4	5,5	6,4	8	10,3	5,5	7,5
		3x415V AC4	kW	-	2,2	3	3,1	3,8	5,5	3	4
		1x400V AC3	kW	-	2,2	3	3,6	4,5	5,7	3	4
		1x400V AC4	kW	-	0,75	1,1	1,7	2,2	3	1,1	1,5
		3x500V AC23A	kW	-	5,5	7,5	9	11	14	7,5	11
		3x500V AC3	kW	-	4	7,5	7,8	9,7	12,5	7,5	11
3x500V AC4	kW	-	2,2	3	3,3	4,7	5,5	3	4		
3x690V AC23A	kW	-	-	-	-	-	-	7,5	11		
3x690V AC3	kW	-	-	-	-	-	-	5,5	7,5		
3x690V AC4	kW	-	-	-	-	-	-	3	4		
Rated conditional short-circuit current	kA	5	10	10	5	5	5	5	5	5	
Rated maximum current	gL-gG	A	16	25	25	35	35	35	20	25	
Rated breaking capacity	400V; cos φ=0,45	A	80	80	100	160	200	256	100	160	
Rated short-time withstand current (1 sec)	A	100	240	400	240	400	500	350	400	500	
Mechanical durability (thousand of operations)		2000	1000	1000	1000	1000	1000	1000	1000	1000	
Rigid copper conductor	mm ²	2x4	2x4	2x4	1x10 2x6	1x10 2x6	1x10 2x6	1x10	1x10	1x10	
Flexible copper conductor	mm ²	2x2,5	2x2,5	2x2,5	1x6 2x4	1x6 2x4	1x6 2x4	1x6	1x6	1x6	
According to UL508 - CAN / CSA C22.2 N° 14			T12	T20				TF12	TF16	TF25	
Rated thermal current	I _{th}	A	12	20	-	-	-	16	20	25	
General use rating	Vac		300	300	-	-	-	600	600	600	
AC rated operational power	3x240V	HP	2	5	-	-	-	2	5	7,5	
	3x480V	HP	-	-	-	-	-	5	10	12	
	3x600V	HP	-	-	-	-	-	5	10	15	

Normal service conditions:

Ambient air temperature (°C): -5°...+40°. Maximum altitude: 2.000 m. Maximum humidity: 90%. Pollution degree: 3 (standard for industrial applications). Rated frequency at AC utilization categories: 50/60 Hz.

Rated duties at utilization categories AC21A, AC22A and AC23A: Continuing (8 hours); uninterrupted.
Rated duties at utilization categories AC3 and AC4: Intermittent; temporary.



Series | Amp

- TP-0010
- T-00012
- T-00020
- TB-00020
- TB-00025
- TB-00032
- TF-00012
- TF-00016
- TF-00025

Diagram

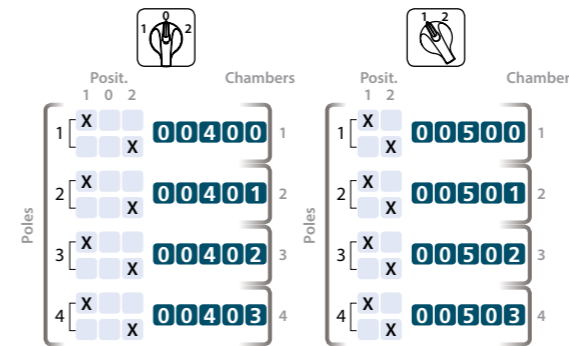

Type

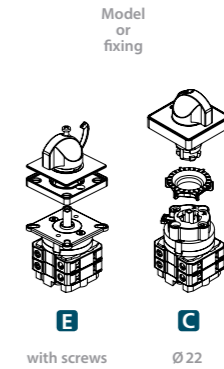
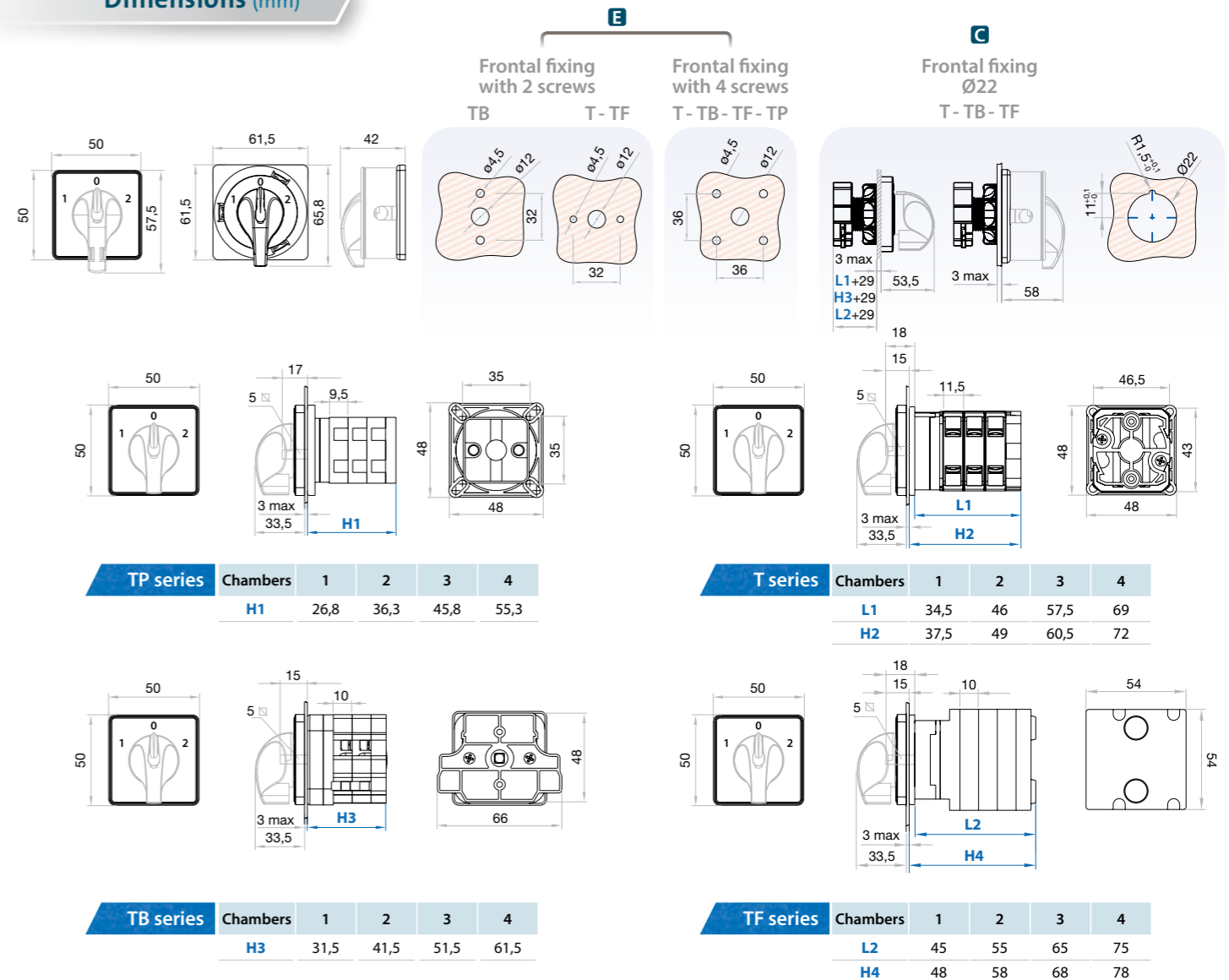

Plate and handle



Dimensions (mm)



T|TB|TF

Base mounting changeover with clutch device 1P up to 4P

Size 0
A 12|16|20|25|32

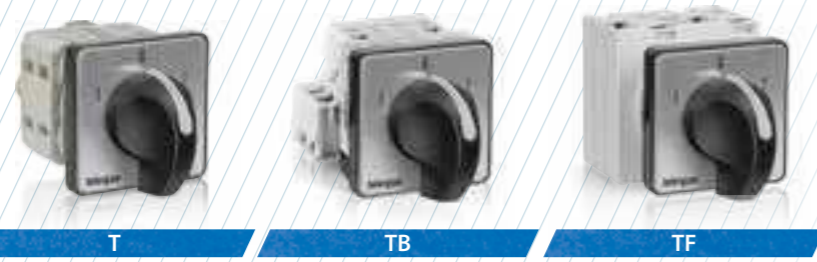

Technical information



According to IEC/EN 60947-3
UL508 - CAN/CSA C22.2 N° 14

According to IEC 60947-3			T12	T20	TB20	TB25	TB32	TF12	TF16	TF25	
Rated thermal current	I _{th}	A	16	25	20	25	32	20	25	32	
Rated insulation voltage	U _i	V	500	500	500	500	500	690	690	690	
Rated impulse withstand voltage	U _{imp}	kV	6	6	6	6	6	6	6	6	
AC rated operational current	I _e	Ue 415V AC21A	A	16	25	20	25	32	20	25	32
		Ue 415V AC22A	A	16	25	20	25	32	20	25	32
		Ue 415V AC23A	A	-	-	20	25	32	-	-	-
		Ue 500V AC21A	A	16	20	20	25	32	-	-	-
		Ue 500V AC22A	A	16	20	20	25	32	-	-	-
		Ue 500V AC23A	A	-	-	16	20	25	-	-	-
		Ue 690V AC21A	A	-	-	-	-	-	16	25	32
		Ue 690V AC22A	A	-	-	-	-	-	16	25	25
		3x240V AC23A	kW	4	4	5,4	6,7	8,6	4	5,5	7,5
		3x240V AC3	kW	3	4	3,7	4,6	5,9	4	5,5	5,5
AC rated operational power	P _e	3x240V AC4	kW	1,1	1,5	2,9	3,7	4,6	1,5	2,2	3
		1x240V AC3	kW	1,5	2,2	2,1	2,7	4	2,2	3	4
		1x240V AC4	kW	0,37	0,55	1	1,25	1,5	0,55	0,75	1,1
		3x415V AC23A	kW	5,5	7,5	9,3	11,7	15	7,5	11	11
		3x415V AC3	kW	4	5,5	6,4	8	10,3	5,5	7,5	7,5
		3x415V AC4	kW	2,2	3	3,1	3,8	5,5	3	4	5,5
		1x400V AC3	kW	2,2	3	3,6	4,5	5,7	3	4	5,5
		1x400V AC4	kW	0,75	1,1	1,7	2,2	3	1,1	1,5	1,5
		3x500V AC23A	kW	5,5	7,5	9	11	14	7,5	11	11
		3x500V AC4	kW	4	7,5	7,8	9,7	12,5	7,5	7,5	11
Rated conditional short-circuit current	I _{cs}	3x690V AC23A	kW	-	-	-	-	7,5	11	15	
		3x690V AC3	kW	-	-	-	-	5,5	7,5	11	
		3x690V AC4	kW	-	-	-	-	3	4	5,5	
Rated maximum current	I _g -gG	A	25	25	35	35	35	20	25	32	
Rated breaking capacity	I _b	A	80	100	160	200	256	100	160	200	
Rated short-time withstand current (1 sec)	I _{st}	A	240	400	240	400	500	350	400	500	
Mechanical durability (thousand of operations)			1000	1000	1000	1000	1000	1000	1000	1000	
Rigid copper conductor		mm ²	2x4	2x4	1x10 2x6	1x10 2x6	1x10 2x6	1x10	1x10	1x10	
Flexible copper conductor		mm ²	2x2,5	2x2,5	1x6 2x4	1x6 2x4	1x6 2x4	1x6	1x6	1x6	
According to UL508 - CAN / CSA C22.2 N° 14			T12	T20				TF12	TF16	TF25	
Rated thermal current	I _{th}	A	12	20	-	-	-	16	20	25	
General use rating		Vac	300	300	-	-	-	600	600	600	
AC rated operational power	P _e	3x240V	HP	2	5	-	-	-	2	5	7,5
		3x480V	HP	-	-	-	-	-	5	10	12
		3x600V	HP	-	-	-	-	-	5	10	15

Normal service conditions:

Ambient air temperature (°C): -5°...+40°. Maximum altitude: 2.000 m. Maximum humidity: 90%. Pollution degree: 3 (standard for industrial applications). Rated frequency at AC utilization categories: 50/60 Hz.
Rated duties at utilization categories AC21A, AC22A and AC23A: Continuing (8 hours); uninterrupted.
Rated duties at utilization categories AC3 and AC4: Intermittent; temporary.



Series | Amp

- TP-0010
- T-00012
- T-00020
- TB-0020
- TB-0025
- TB-0032
- TF-0012
- TF-0016
- TF-0025

Diagram

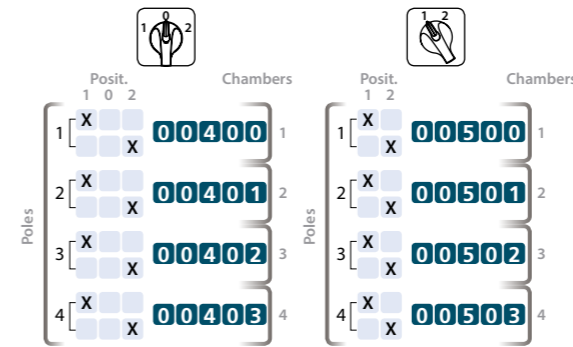
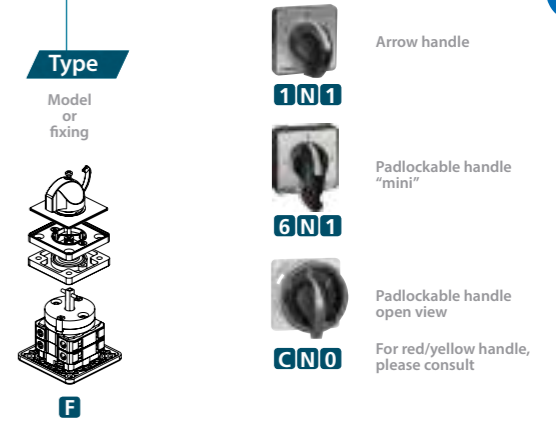
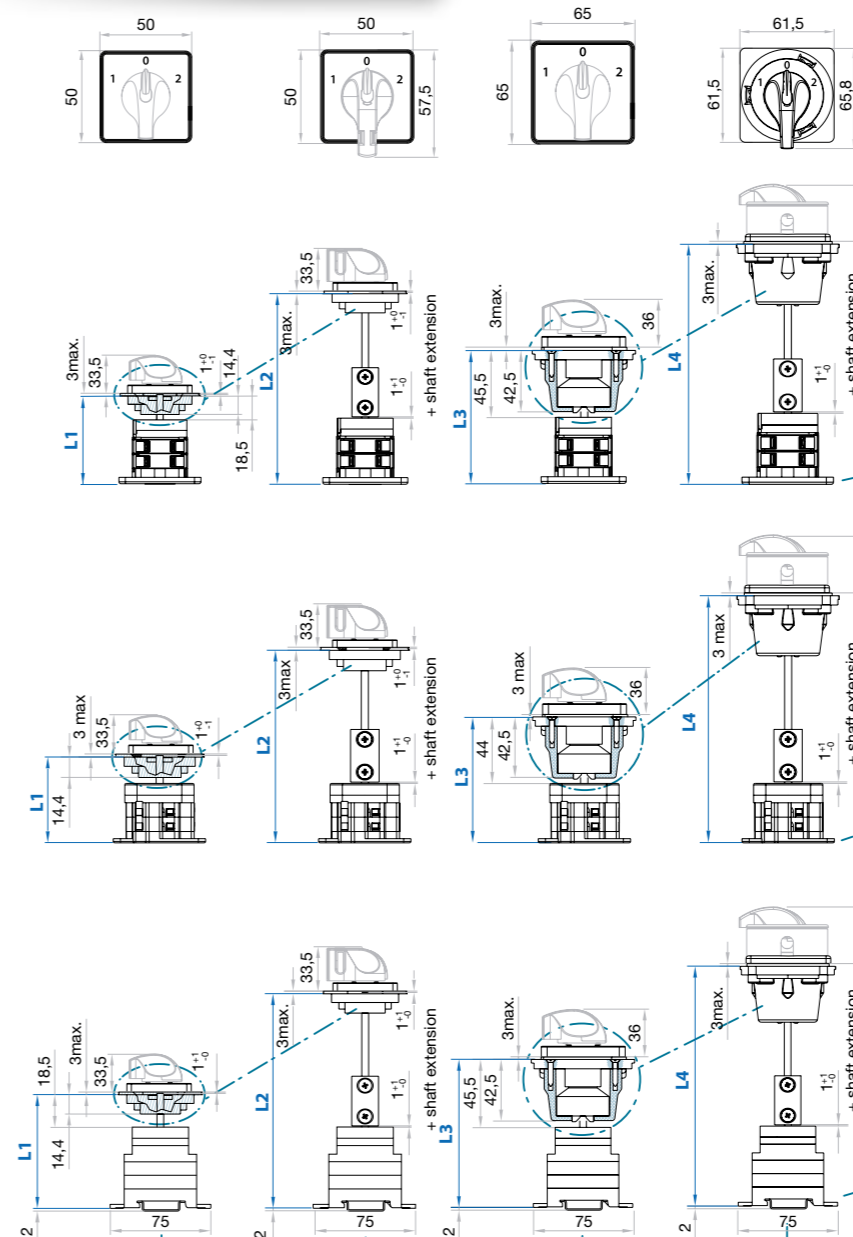

Plate and handle



Dimensions (mm)



Frontal panel mechanization with 2 or 4 screws

L1-L2

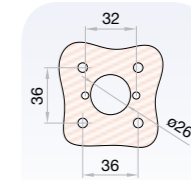

Frontal panel mechanization with 2 or 4 screws

L3-L4

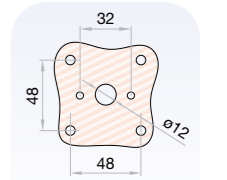

T series	Chambers	1	+	1	+	1	+	1	+
		L1		L2		L3		L4	
min		56	+11,5	94	+11,5	83	+11,5	121	+11,5
max				256				283	

L2 - L4 Specify length when ordering

TB series	Chambers	1	+	1	+	1	+	1	+
		L1		L2		L3		L4	
min		46	+10	84	+10	75,5	+10	113	+10
max				246				275,5	

L2 - L4 Specify length when ordering

TF series	Chambers	1	+	1	+	1	+	1	+
		L1		L2		L3		L4	
min		65,5	+10	103,5	+10	92,5	+10	130,5	+10
max				265,5				292,5	

L2 - L4 Specify length when ordering

IEC60715/TH35-7,5
DIN46277

» For more information of these series; accessories see pages 40-47 | diagrams see pages 50-59

T Door mounting changeover

1P up to 4P

Size 1
A 16|25|32|40



T

Technical information



According to IEC/EN 60947-3
 UL508 - CAN/CSA C22.2 N° 14

According to IEC 60947-3			T16	T25	T32	T40	
Rated thermal current	I _{th}	A	25	32	40	50	
Rated insulation voltage	U _i	V	690	690	690	690	
Rated impulse withstand voltage	U _{imp}	kV	6	6	8	8	
AC rated operational current	I _e	U _e 415V AC21A	A	25	32	40	50
		U _e 415V AC22A	A	25	32	40	50
		U _e 690V AC21A	A	25	32	40	50
		U _e 690V AC22A	A	25	25	40	40
		3x240V AC23A	kW	5,5	7,5	11	15
		3x240V AC3	kW	5,5	5,5	7,5	11
AC rated operational power (Rated operational frequency 50/60 Hz)	P _e	3x240V AC4	kW	2,2	3	4	4
		1x240V AC3	kW	3	4	5,5	5,5
		1x240V AC4	kW	0,75	1,1	1,5	2,2
		3x415V AC23A	kW	11	11	15	18,5
		3x415V AC3	kW	7,5	7,5	11	15
		3x415V AC4	kW	4	5,5	5,5	7,5
		1x400V AC3	kW	4	5,5	7,5	7,5
		1x400V AC4	kW	1,5	1,5	2,2	3
		3x500V AC23A	kW	11	11	15	18,5
		3x500V AC3	kW	7,5	11	11	15
		3x500V AC4	kW	4	5,5	5,5	7,5
		3x690V AC23A	kW	11	15	18,5	30
3x690V AC3	kW	7,5	11	15	22		
3x690V AC4	kW	4	5,5	5,5	7,5		
Rated conditional short-circuit current		kA	10	10	10	10	
Rated maximum current	gL-gG	A	32	32	50	50	
Rated breaking capacity	400V; cos φ=0,45	A	160	200	256	320	
Rated short-time withstand current (1 sec)		A	500	650	725	800	
Mechanical durability (thousand of operations)			1000	1000	1000	1000	
Rigid copper conductor		mm ²	2x6	2x6	2x10	2x10	
Flexible copper conductor		mm ²	2x4	2x4	2x6	2x6	
According to UL508 - CAN / CSA C22.2 N° 14			T16	T25	T32	T40	
Rated thermal current	I _{th}	A	16	25	32	40	
General use rating		Vac	600	600	600	600	
AC rated operational power	3x240V	HP	5,3	7,5	10	15	
	3x480V	HP	15	15	20	25	
	3x600V	HP	20	20	25	30	

Normal service conditions:

Ambient air temperature (°C): -5°...+40°. Maximum altitude: 2.000 m. Maximum humidity: 90%. Pollution degree: 3 (standard for industrial applications). Rated frequency at AC utilization categories: 50/60 Hz.
 Rated duties at utilization categories AC21A, AC22A and AC23A: Continuing (8 hours); uninterrupted.
 Rated duties at utilization categories AC3 and AC4: Intermittent; temporary.

Code 1 2 3 4 5 6 7 8 9 10 11 12 13 14 15 16

Series | Amp
 T-00016
 T-00025
 T-00032
 T-00040

Diagram

Type
 Model or fixing
 with screws (E) Ø22 (C)

Plate and handle
 Arrow handle (1N1)
 Padlockable handle open view (CNO)
 For red/yellow handle, please consult

Dimensions (mm)

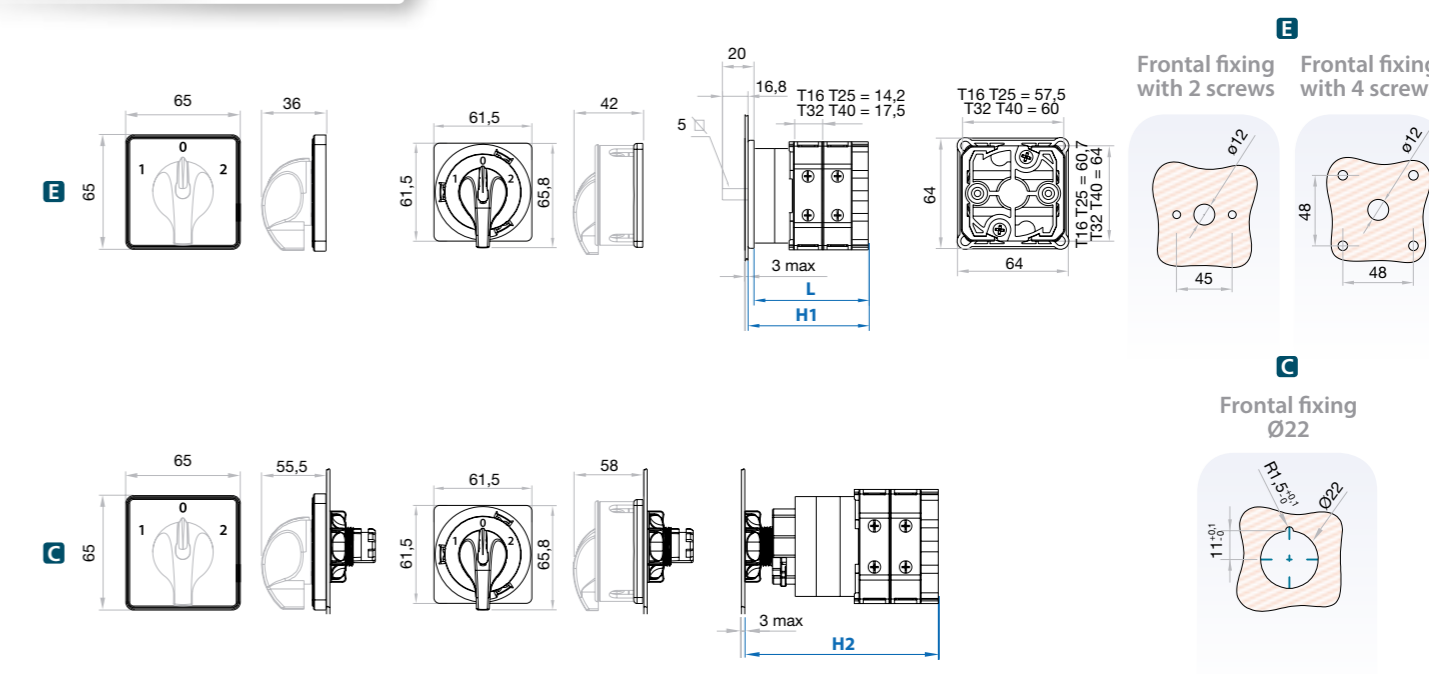

T series	Chambers	1□	2□	3□	4□
T16 T25	L	46,4	60,6	74,8	89
	H1	49,6	63,8	78	92,2
	H2	75,5	89,5	103,7	117,9
T32 T40	L	49,8	67,3	84,8	102,3
	H1	53	70,5	88	105,5
	H2	78,8	96,3	113,8	131,3

T Base mounting changeover with clutch device 1P up to 4P

Size 1
A 16|25|32|40



T

Technical information



According to IEC/EN 60947-3
UL508 - CAN/CSA C22.2 N° 14

According to IEC 60947-3			T16	T25	T32	T40	
Rated thermal current	Ith	A	25	32	40	50	
Rated insulation voltage	Ui	V	690	690	690	690	
Rated impulse withstand voltage	Uimp	kV	6	6	8	8	
AC rated operational current	Ie	Ue 415V AC21A	A	25	32	40	50
		Ue 415V AC22A	A	25	32	40	50
	Ue 690V AC21A	A	25	32	40	50	
	Ue 690V AC22A	A	25	25	40	40	
	3x240V AC23A	kW	5,5	7,5	11	15	
	3x240V AC3	kW	5,5	5,5	7,5	11	
	3x240V AC4	kW	2,2	3	4	4	
	1x240V AC3	kW	3	4	5,5	5,5	
	1x240V AC4	kW	0,75	1,1	1,5	2,2	
	3x415V AC23A	kW	11	11	15	18,5	
AC rated operational power (Rated operational frequency 50/60 Hz)	Pe	3x415V AC3	kW	7,5	7,5	11	15
		3x415V AC4	kW	4	5,5	5,5	7,5
	1x400V AC3	kW	4	5,5	7,5	7,5	
	1x400V AC4	kW	1,5	1,5	2,2	3	
	3x500V AC23A	kW	11	11	15	18,5	
	3x500V AC3	kW	7,5	11	11	15	
	3x500V AC4	kW	4	5,5	5,5	7,5	
	3x690V AC23A	kW	11	15	18,5	30	
	3x690V AC3	kW	7,5	11	15	22	
	3x690V AC4	kW	4	5,5	5,5	7,5	
Rated conditional short-circuit current		kA	10	10	10	10	
Rated maximum current	gL-gG	A	32	32	50	50	
Rated breaking capacity	400V; cos φ=0,45	A	160	200	256	320	
Rated short-time withstand current (1 sec)		A	500	650	725	800	
Mechanical durability (thousand of operations)			1000	1000	1000	1000	
Rigid copper conductor		mm ²	2x6	2x6	2x10	2x10	
Flexible copper conductor		mm ²	2x4	2x4	2x6	2x6	
According to UL508 - CAN / CSA C22.2 N° 14			T16	T25	T32	T40	
Rated thermal current	Ith	A	16	25	32	40	
General use rating		Vac	600	600	600	600	
AC rated operational power	3x240V	HP	5,3	7,5	10	15	
	3x480V	HP	15	15	20	25	
	3x600V	HP	20	20	25	30	

Normal service conditions:
Ambient air temperature (°C): -5°...+40°. Maximum altitude: 2.000 m. Maximum humidity: 90%. Pollution degree: 3 (standard for industrial applications). Rated frequency at AC utilization categories: 50/60 Hz.
Rated duties at utilization categories AC21A, AC22A and AC23A: Continuing (8 hours); uninterrupted.
Rated duties at utilization categories AC3 and AC4: Intermittent; temporary.

Series | Amp

T-00016
T-00025
T-00032
T-00040

Code 1 2 3 4 5 6 7 8 9 10 11 12 13 14 15 16

Diagram

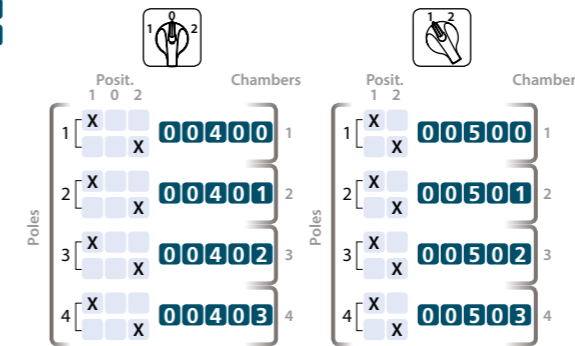

Type

Model or fixing

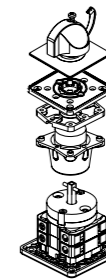

F

Plate and handle



Arrow handle

1N1



Padlockable handle open view

CN0

For red/yellow handle, please consult

Dimensions (mm)

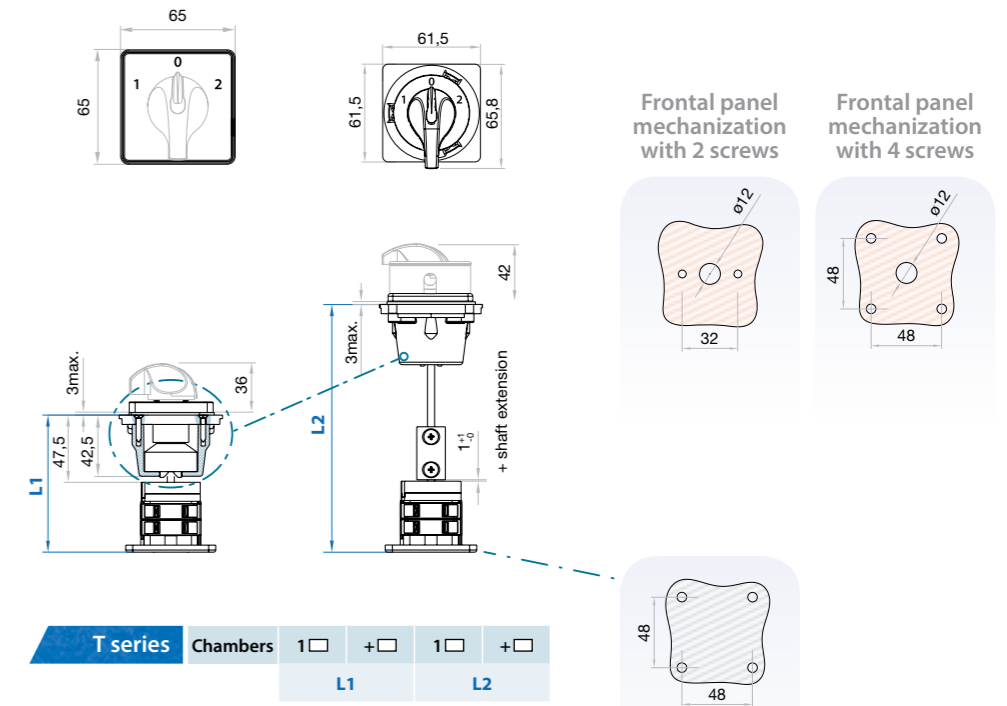

T series Chambers

	Chambers	1 □ + □		1 □ + □	
		L1	L2	L1	L2
T16 T25	min	97,1	+14,2	135,1	+14,2
	max			297,1	
T32 T40	min	100,5	+17,5	138,5	+17,5
	max			300,5	

L2
Specify length when ordering

T Door mounting changeover

1P up to 4P

Size 2
A 50|63|80|100|125|175

* Except T175



T

Technical information



According to IEC/EN 60947-3
UL508 - CAN/CSA C22.2 N° 14

According to IEC 60947-3		T50	T63	T80	T100	T125	T175		
Rated thermal current	Ith	A	63	80	80	125	125	200	
Rated insulation voltage	Ui	V	690	690	690	690	690	1000	
Rated impulse withstand voltage	Uimp	kV	8	8	8	8	8	8	
AC rated operational current	Ie	Ue 415V AC21A	A	63	80	80	125	125	200
		Ue 415V AC22A	A	63	80	80	115	115	200
		Ue 690V AC21A	A	63	80	80	115	115	175
		Ue 690V AC22A	A	63	63	63	100	100	160
		3x240V AC23A	kW	18,5	22	22	30	30	55
		3x240V AC3	kW	15	18,5	18,5	30	30	37
AC rated operational power (Rated operational frequency 50/60 Hz)	Pe	3x240V AC4	kW	5,5	7,5	7,5	11	11	15
		1x240V AC3	kW	7,5	11	11	15	15	18,5
		1x240V AC4	kW	3	3	3	4	4	5,5
		3x415V AC23A	kW	30	37	37	45	45	90
		3x415V AC3	kW	22	30	30	37	37	75
		3x415V AC4	kW	11	11	11	15	15	18,5
		1x400V AC3	kW	15	18,5	18,5	18,5	18,5	20
		1x400V AC4	kW	4	5,5	5,5	7,5	7,5	11
		3x500V AC23A	kW	30	37	37	55	55	110
		3x500V AC3	kW	22	30	30	45	45	75
		3x500V AC4	kW	11	11	11	15	15	18,5
		3x690V AC23A	kW	37	45	45	55	55	75
3x690V AC3	kW	37	45	45	45	45	55		
3x690V AC4	kW	11	11	11	15	15	18,5		
Rated conditional short-circuit current		kA	15	15	15	15	15	15 ⁽²⁾	
Rated maximum current	gL-gG	A	80	80	80	125	125	160	
Rated breaking capacity	400V; cos φ=0,45	A	504	504	504	640	640	1600	
Rated short-time withstand current (1 sec)		A	1600	1600	1600	2500	2500	3500	
Mechanical durability (thousand of operations)			1000	1000	1000	1000	1000	1000	
Rigid copper conductor		mm ²	16/25 ⁽¹⁾	16/25 ⁽¹⁾	16/25 ⁽¹⁾	35/50 ⁽¹⁾	35/50 ⁽¹⁾	95	
Flexible copper conductor		mm ²	10/16 ⁽¹⁾	10/16 ⁽¹⁾	10/16 ⁽¹⁾	16/35 ⁽¹⁾	16/35 ⁽¹⁾	95	
According to UL508 - CAN / CSA C22.2 N° 14			T50	T63	T80	T100	T125	T175	
Rated thermal current	Ith	A	63	63	63	100	100		
General use rating		Vac	600	600	600	600	600		
AC rated operational power	3x240V	HP	20	20	20	30	30		
	3x480V	HP	40	40	40	50	50		
	3x600V	HP	40	40	40	50	50		

⁽¹⁾ With terminals for connection

⁽²⁾ Mounting without connection terminals or terminals + phase barriers DT-90025

Normal service conditions:

Ambient air temperature (°C): -5°...+40°. Maximum altitude: 2.000 m. Maximum humidity: 90%. Pollution degree: 3 (standard for industrial applications). Rated frequency at AC utilization categories: 50/60 Hz.

Rated duties at utilization categories AC21A, AC22A and AC23A: Continuing (8 hours); uninterrupted.

Rated duties at utilization categories AC3 and AC4: Intermittent; temporary.



Series | Amp

T-00050
T-00063
T-00080
T-00100
T-00125
T-00175

Diagram

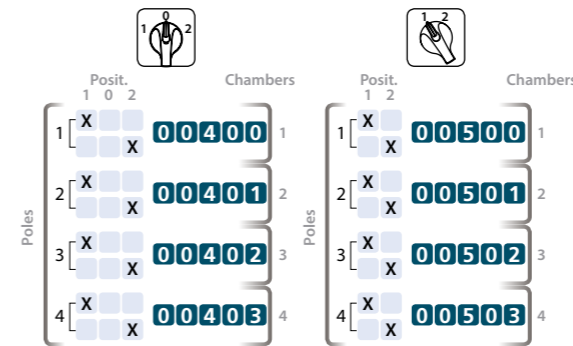

Type

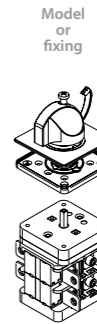

Plate and handle



Arrow handle

1N1

Padlockable handle open view

CNO

For red/yellow handle, please consult

E

Dimensions (mm)

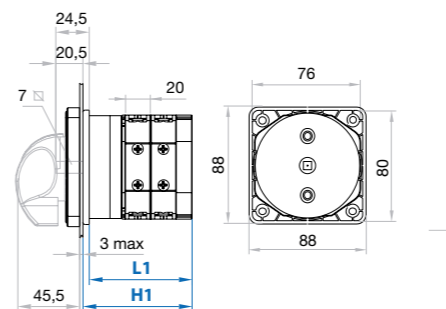
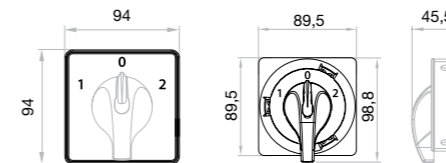

Frontal fixing with 2 screws

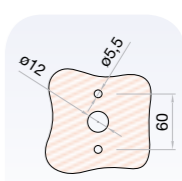

Frontal fixing with 4 screws

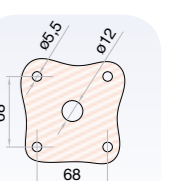

T series	Chambers	1□	2□	3□	4□
T100	L2	67	94	121	148
T125	H2	71	98	125	152

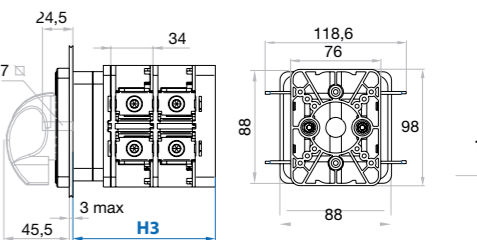

T series	Chambers	1□	2□	3□	4□
T175	H3	80,8	114,8	148,8	182,8

T series	Chambers	1□	2□	3□	4□
T50	L1	58,5	78,5	98,5	118,5
T63	H1	62,5	82,5	102,5	122,5
T80					

» For more information of these series; accessories see pages 40-47 | diagrams see pages 50-59

T Base mounting changeover with clutch device 1P up to 4P

Size 2
A 50|63|80|100|125|175

* Except T175



Technical information



According to IEC/EN 60947-3
UL508 - CAN/CSA C22.2 N° 14

According to IEC 60947-3		T50	T63	T80	T100	T125	T175		
Rated thermal current	Ith	A	63	80	80	125	125	200	
Rated insulation voltage	Ui	V	690	690	690	690	690	1000	
Rated impulse withstand voltage	Uimp	kV	8	8	8	8	8	8	
AC rated operational current	Ie	Ue 415V AC21A	A	63	80	80	125	125	200
		Ue 415V AC22A	A	63	80	80	115	115	200
	Ue 690V AC21A	A	63	80	80	115	115	175	
	Ue 690V AC22A	A	63	63	63	100	100	160	
	3x240V AC23A	kW	18,5	22	22	30	30	55	
	3x240V AC3	kW	15	18,5	18,5	30	30	37	
	3x240V AC4	kW	5,5	7,5	7,5	11	11	15	
	1x240V AC3	kW	7,5	11	11	15	15	18,5	
	1x240V AC4	kW	3	3	3	4	4	5,5	
	3x415V AC23A	kW	30	37	37	45	45	90	
AC rated operational power (Rated operational frequency 50/60 Hz)	Pe	3x415V AC3	kW	22	30	30	37	37	75
		3x415V AC4	kW	11	11	11	15	15	18,5
	1x400V AC3	kW	15	18,5	18,5	18,5	18,5	20	
	1x400V AC4	kW	4	5,5	5,5	7,5	7,5	11	
	3x500V AC23A	kW	30	37	37	55	55	110	
	3x500V AC3	kW	22	30	30	45	45	75	
	3x500V AC4	kW	11	11	11	15	15	18,5	
	3x690V AC23A	kW	37	45	45	55	55	75	
	3x690V AC3	kW	37	45	45	45	45	55	
	3x690V AC4	kW	11	11	11	15	15	18,5	
Rated conditional short-circuit current		kA	15	15	15	15	15	15 ⁽²⁾	
Rated maximum current	gL-gG	A	80	80	80	125	125	160	
Rated breaking capacity	400V; cos φ=0,45	A	504	504	504	640	640	1600	
Rated short-time withstand current (1 sec)		A	1600	1600	1600	2500	2500	3500	
Mechanical durability (thousand of operations)			1000	1000	1000	1000	1000	1000	
Rigid copper conductor		mm ²	16/25 ⁽¹⁾	16/25 ⁽¹⁾	16/25 ⁽¹⁾	35/50 ⁽¹⁾	35/50 ⁽¹⁾	95	
Flexible copper conductor		mm ²	10/16 ⁽¹⁾	10/16 ⁽¹⁾	10/16 ⁽¹⁾	16/35 ⁽¹⁾	16/35 ⁽¹⁾	95	
According to UL508 - CAN / CSA C22.2 N° 14		T50	T63	T80	T100	T125	T175		
Rated thermal current	Ith	A	63	63	63	100	100		
General use rating		Vac	600	600	600	600	600	Certification in progress	
AC rated operational power	3x240V	HP	20	20	20	30	30		
	3x480V	HP	40	40	40	50	50		
	3x600V	HP	40	40	40	50	50		

*⁽¹⁾ With terminals for connection

*⁽²⁾ Mounting without connection terminals or terminals + phase barriers DT-90025

Normal service conditions:

Ambient air temperature (°C): -5°...+40°. Maximum altitude: 2.000 m. Maximum humidity: 90%. Pollution degree: 3 (standard for industrial applications). Rated frequency at AC utilization categories: 50/60 Hz.

Rated duties at utilization categories AC21A, AC22A and AC23A: Continuing (8 hours); uninterrupted.

Rated duties at utilization categories AC3 and AC4: Intermittent; temporary.

Code 1 2 3 4 5 6 7 8 9 10 11 12 13 14 15 16

Series | Amp

T-00050
T-00063
T-00080
T-00100
T-00125
T-00175

Diagram

Type

Plate and handle

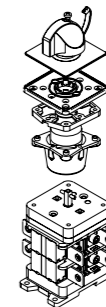
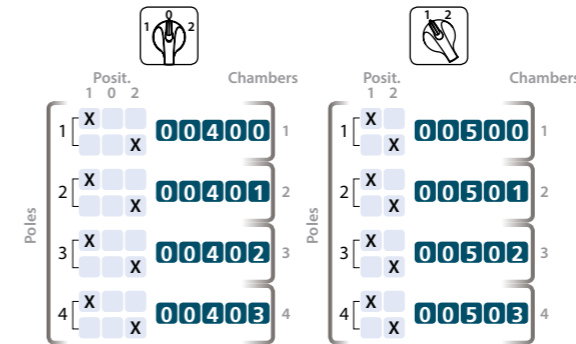

1N1



CN0 For red/yellow handle, please consult

Dimensions (mm)

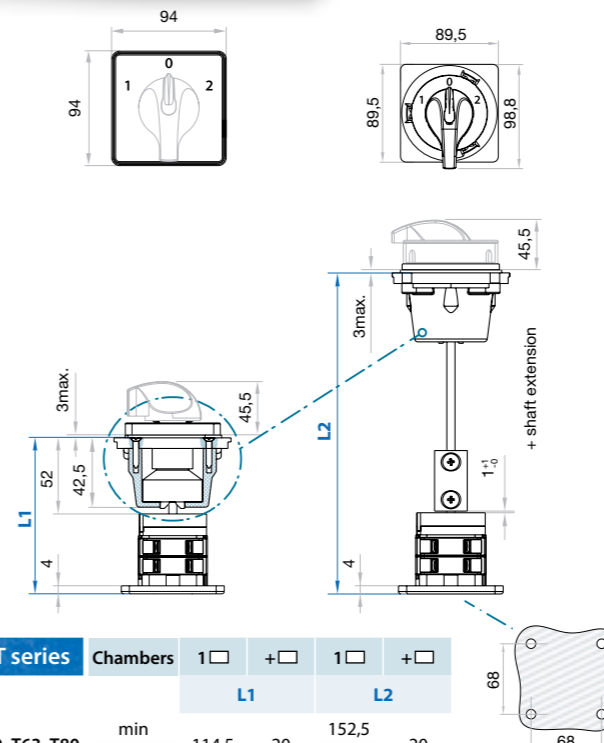

T series	Chambers	1	+	1	+
		L1		L2	
T50 T63 T80	min	114,5	20	152,5	20
	max			314,5	
T100 T125	min	123	27	161	27
	max			323	

T series	Chambers	1	+	1	+
		L3		L4	
T175	min	141,8	34	179,8	34
	max			341,8	

L4 Specify length when ordering

L2 Specify length when ordering

DIN rail support

Code DT-90421 (1 unit)

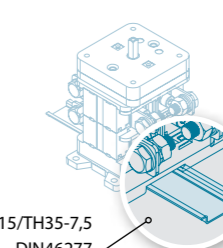
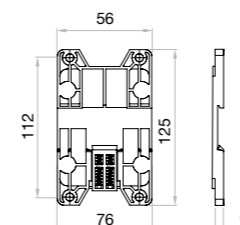

DIN rail or 4 screws included in the D or F fixing T175 types

The maximum number of chambers advisable is 3, for further conditions please consult

>> For more information of these series; accessories see pages 40-47 | diagrams see pages 50-59

T Door mounting changeover

1P up to 4P

Size 3
A 200|250|315



Technical information



According to IEC/EN 60947-3
UL508 - CAN/CSA C22.2 N° 14

According to IEC 60947-3			T200	T250	T315	
Rated thermal current	Ith	A	200	250	315	
Rated insulation voltage	Ui	V	690	690	690	
Rated impulse withstand voltage	Uimp	kV	8	8	8	
AC rated operational current	Ie	Ue 415V AC21A	A	200	250	315
		Ue 415V AC22A	A	200	250	315
	Ue 690V AC21A	A	200	220	250	
	Ue 690V AC22A	A	200	200	200	
	3x240V AC23A	kW	55	67	75	
	3x240V AC3	kW	45	54	61	
	3x240V AC4	kW	15	18	20	
	1x240V AC3	kW	22	22	22	
	1x240V AC4	kW	7,5	9	10	
	3x415V AC23A	kW	90	115	130	
AC rated operational power (Rated operational frequency 50/60 Hz)	Pe	3x415V AC3	kW	75	95	108
		3x415V AC4	kW	22	28	31
	1x400V AC3	kW	37	47	53	
	1x400V AC4	kW	11	14	16	
	3x500V AC23A	kW	110	130	145	
	3x500V AC3	kW	90	106	118	
	3x500V AC4	kW	22	26	29	
	3x690V AC23A	kW	132	155	175	
	3x690V AC3	kW	110	129	145	
	3x690V AC4	kW	22	25	29	
Rated conditional short-circuit current		kA	25	15	15	
Rated maximum current	gL-gG	A	200	250	315	
Rated breaking capacity	400V; cos φ=0,45	A	1450	2000	2240	
Rated short-time withstand current (1 sec)		A	4400	4400	4400	
Mechanical durability (thousand of operations)			1000	1000	1000	
Rigid copper conductor		mm ²	95	120	185	
Flexible copper conductor		mm ²	95	120	185	
According to UL508 - CAN / CSA C22.2 N° 14			T200	T250	T315	
Rated thermal current	Ith	A	200	200	200	
General use rating		Vac	600	600	600	
AC rated operational power		3x240V	HP	60	60	
		3x480V	HP	75	75	
		3x600V	HP	60	60	

Normal service conditions:
Ambient air temperature (°C): -5°...+40°. Maximum altitude: 2.000 m. Maximum humidity: 90%. Pollution degree: 3 (standard for industrial applications). Rated frequency at AC utilization categories: 50/60 Hz.
Rated duties at utilization categories AC21A, AC22A and AC23A: Continuing (8 hours); uninterrupted.
Rated duties at utilization categories AC3 and AC4: Intermittent; temporary.

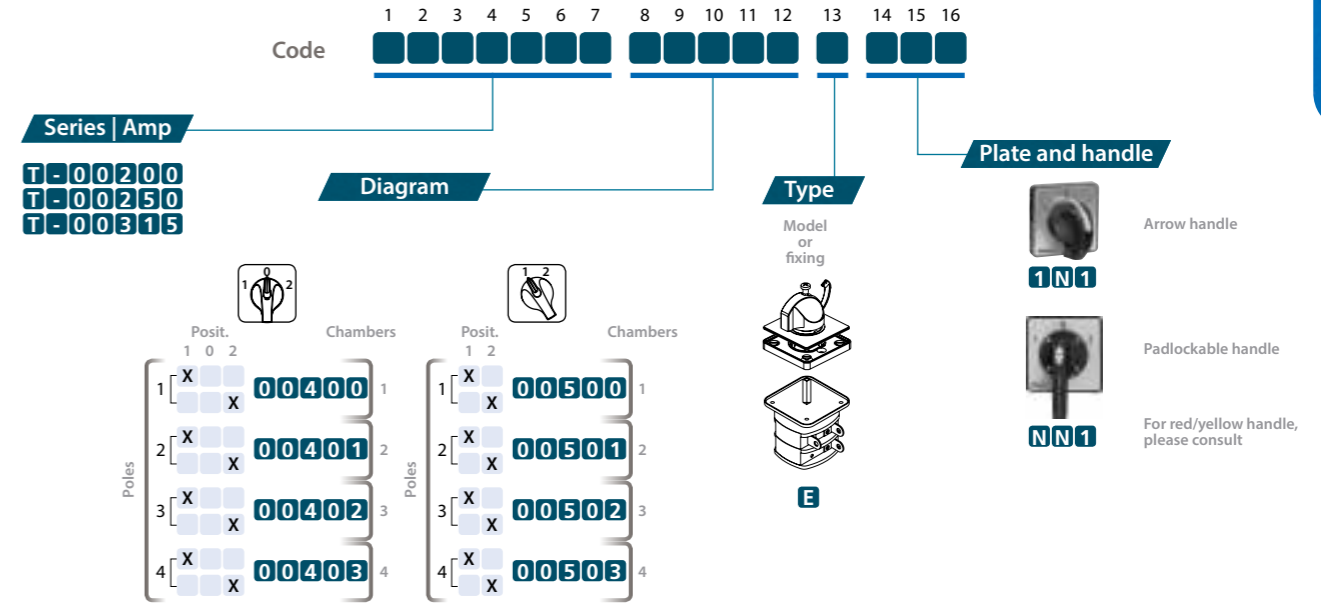

Dimensions (mm)

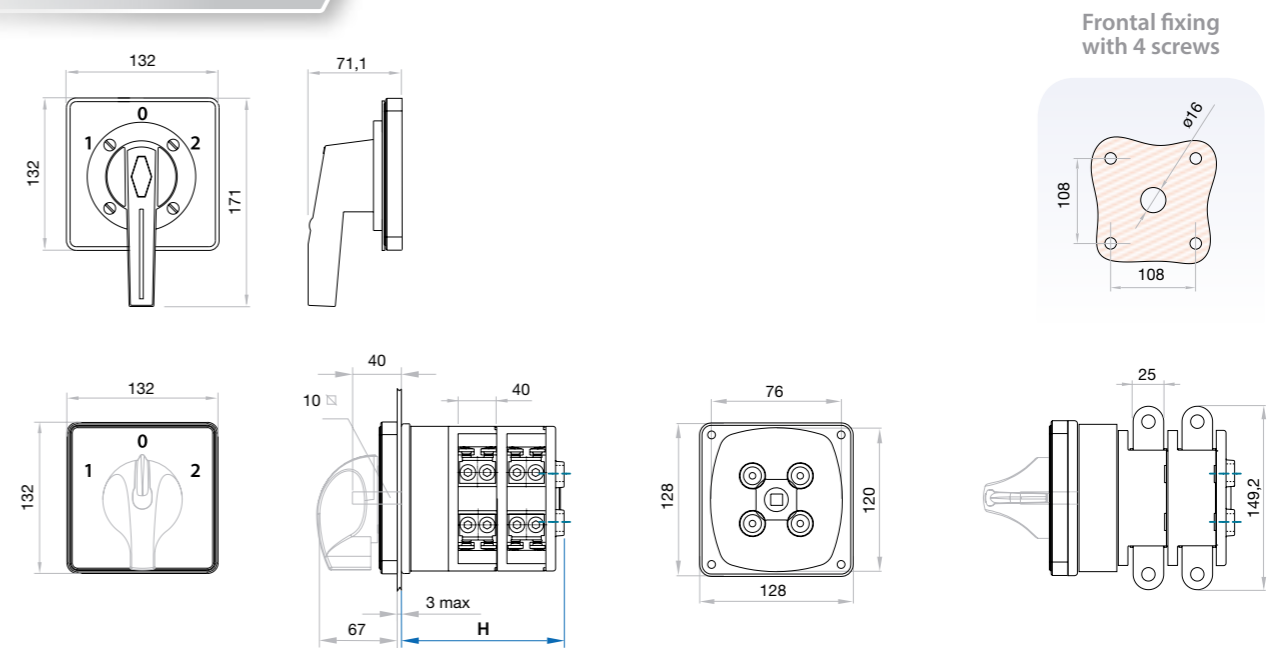

UL Terminal Lug

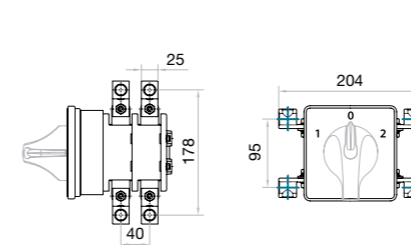

Terminal extensions according to UL.

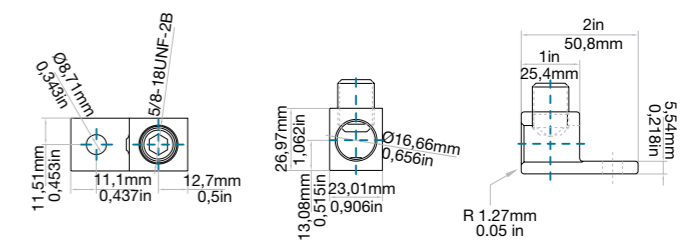

T series	Chambers	1	2	3	4
T200 T250 T315	H	95	135	175	215

Wire size	Wires per lug	Wire type	kit reference
150 mm ² / 300 kcmil	1	Cu/Al	DS-TL01 (2 pieces)

T Base mounting changeover with clutch device 1P up to 4P

Size 3
A 200|250|315



Technical information



According to IEC/EN 60947-3
UL508 - CAN/CSA C22.2 N° 14

According to IEC 60947-3			T200	T250	T315	
Rated thermal current	I _{th}	A	200	250	315	
Rated insulation voltage	U _i	V	690	690	690	
Rated impulse withstand voltage	U _{imp}	kV	8	8	8	
AC rated operational current	I _e	U _e 415V AC21A	A	200	250	315
		U _e 415V AC22A	A	200	250	315
	U _e 690V AC21A	A	200	220	250	
	U _e 690V AC22A	A	200	200	200	
	3x240V AC23A	kW	55	67	75	
	3x240V AC3	kW	45	54	61	
	3x240V AC4	kW	15	18	20	
	1x240V AC3	kW	22	22	22	
	1x240V AC4	kW	7,5	9	10	
	3x415V AC23A	kW	90	115	130	
AC rated operational power (Rated operational frequency 50/60 Hz)	P _e	3x415V AC3	kW	75	95	108
		3x415V AC4	kW	22	28	31
	1x400V AC3	kW	37	47	53	
	1x400V AC4	kW	11	14	16	
	3x500V AC23A	kW	110	130	145	
	3x500V AC3	kW	90	106	118	
	3x500V AC4	kW	22	26	29	
	3x690V AC23A	kW	132	155	175	
	3x690V AC3	kW	110	129	145	
	3x690V AC4	kW	22	25	29	
Rated conditional short-circuit current		kA	25	15	15	
Rated maximum current	g _L -g _G	A	200	250	315	
Rated breaking capacity	400V; cos φ=0,45	A	1450	2000	2240	
Rated short-time withstand current (1 sec)		A	4400	4400	4400	
Mechanical durability (thousand of operations)			1000	1000	1000	
Rigid copper conductor		mm ²	95	120	185	
Flexible copper conductor		mm ²	95	120	185	
According to UL508 - CAN / CSA C22.2 N° 14			T200	T250	T315	
Rated thermal current	I _{th}	A	200	200	200	
General use rating		Vac	600	600	600	
AC rated operational power		HP	60	60	60	
	3x240V	HP	60	60	60	
	3x480V	HP	75	75	75	
	3x600V	HP	60	60	60	

Normal service conditions:
Ambient air temperature (°C): -5°...+40°. Maximum altitude: 2.000 m. Maximum humidity: 90%. Pollution degree: 3 (standard for industrial applications). Rated frequency at AC utilization categories: 50/60 Hz.
Rated duties at utilization categories AC21A, AC22A and AC23A: Continuing (8 hours); uninterrupted.
Rated duties at utilization categories AC3 and AC4: Intermittent; temporary.

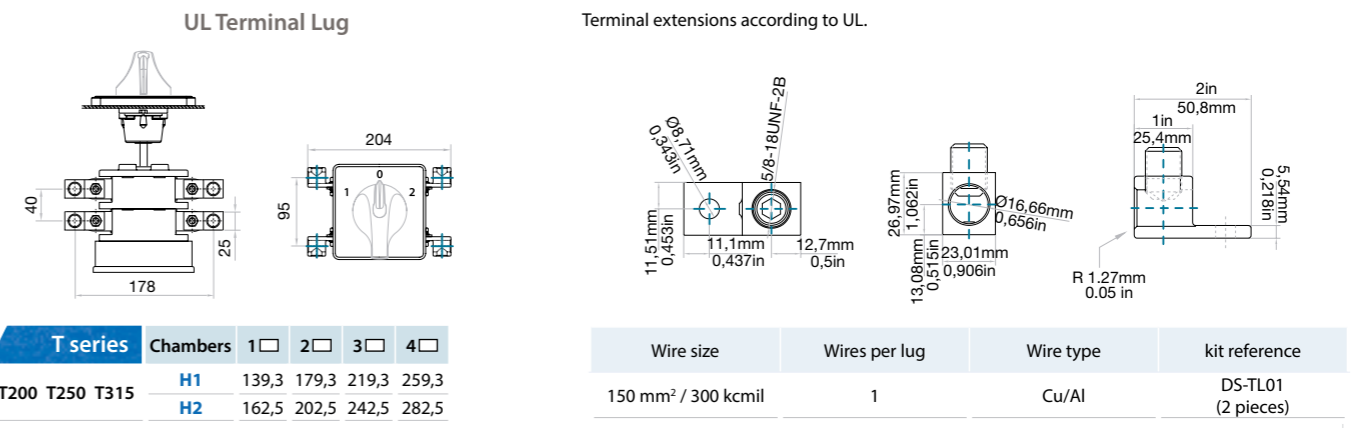
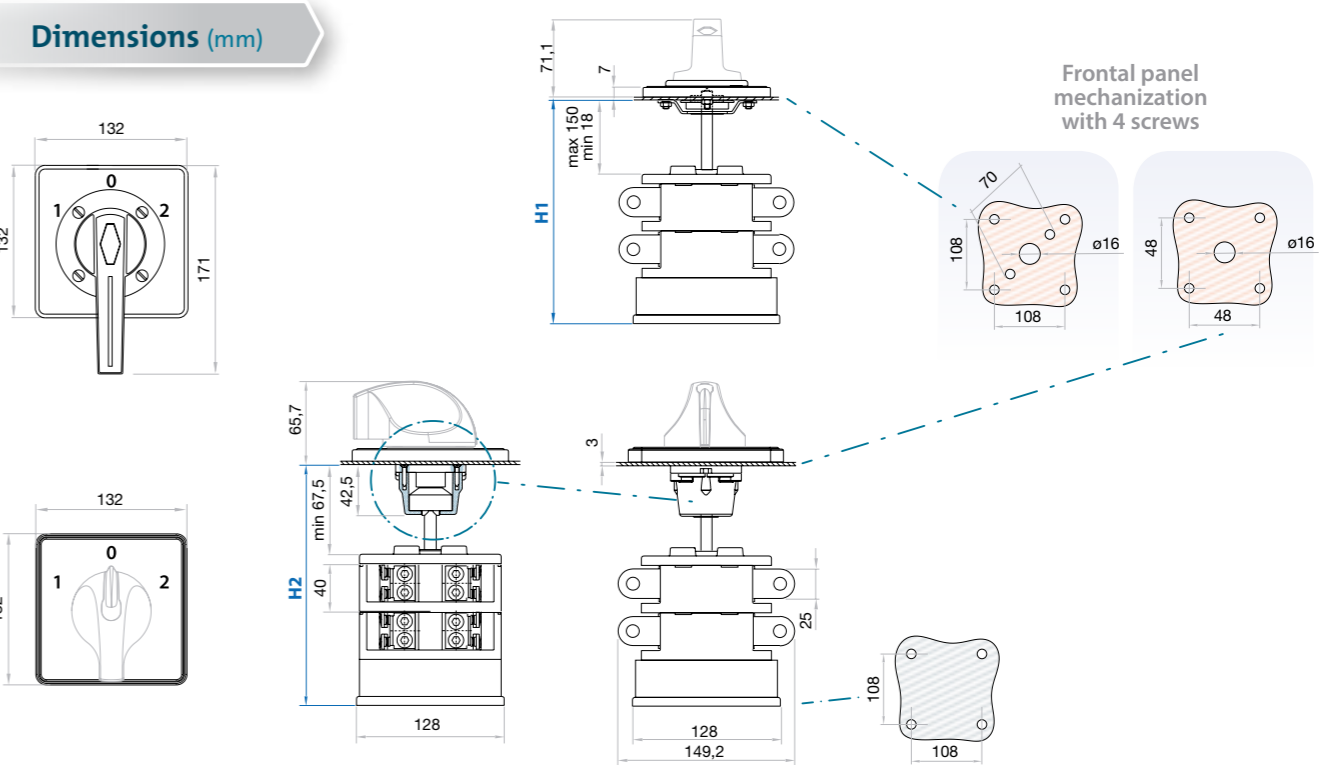
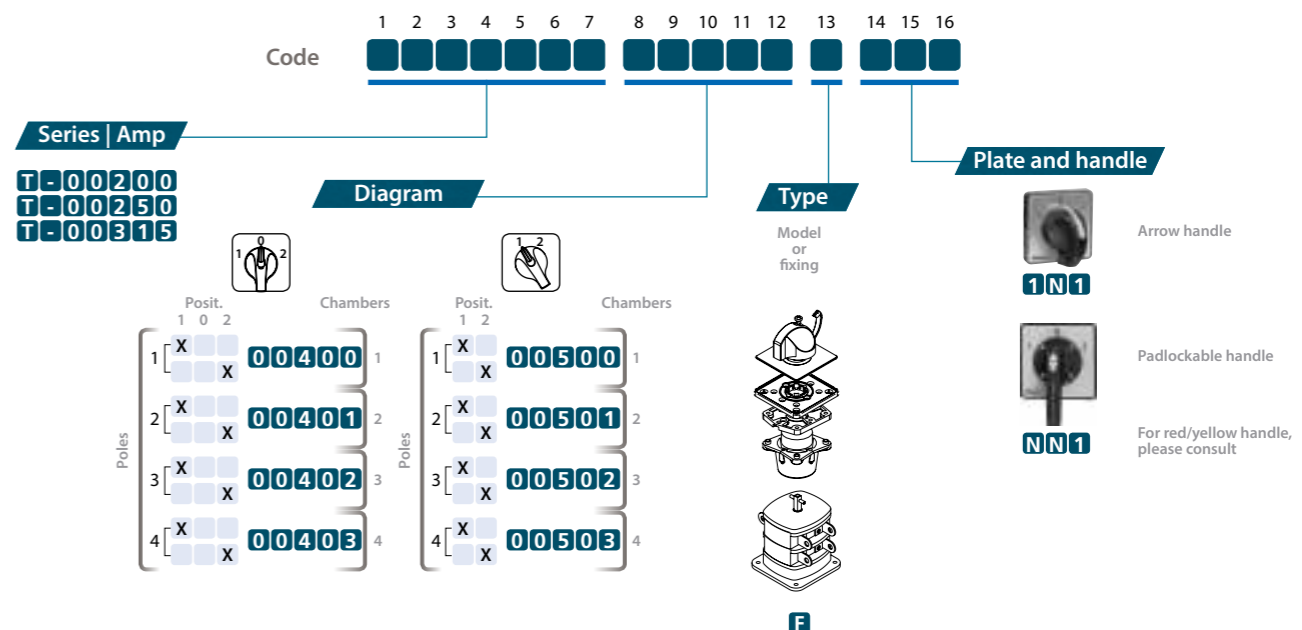

14 15 16
D100 4



Light with white neon lamp
D100

14 15 16
D101 5



Light with white neon lamp and inscription plate
D101

D101 Inscription plate included with text as requested.

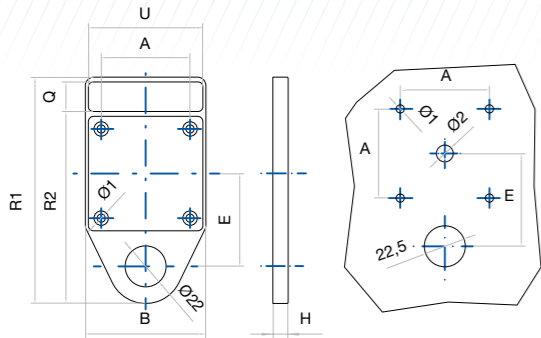

Supply	Size	For series	Code D100	Code D101
Spare or incorporated in the cam switch	0-1	T12-T20-TB20-TB25-TB32 TF12-TF16-TF25 T16-T25-T32-T40	DT-10011	DT-10111
	2	T50-T63-T100-T175	DT-10021	DT-10121
	3	T200	DT-10031	DT-10131

Series	B	R1	R2	H	E	U	Q	A	Ø1	Ø2
T12 T20 T16 T25 T32 T40 TB20 TB32 TF12 TF25	65	123	102	6,5	50	61	16	48	4,5	9
T50 T63 T100 T175	94	160	137	7,5	70	90	19	68	5,5	12
T200 T800	132	198	173	10	85	126	21	108	6,5	16

13 14 15 16
D201 E



Tandem drive operation*
D200 with two columns
D201 with three columns

13 14 15 16
D301 G



Blocking operation*
D300 with two columns
D301 with three columns

Supply	Size	For series
Only incorporated in the cam switch	0-1	T12-T20-TF12-TF16-TF25 T16-T25-T32-T40
	2	T50-T63-T100
	3	T175-T200

* T Series (without IP20 protections).

Series	Tandem		Blocking		A	B	D	R	U	Q	E	H	Ø				
	D200	D300	D201	D301													
T12 T20 T16 T25 T32 T40 TF12 TF16 TF25	D200	D300	D201	D301	56	70	143	157	210	224	64	128	195	67	22	22	4,5
T50 T63 T100	D200	D300	D201	D301	90	110	210	230	306	326	95	191	288	97	15	21	6,5
T175 T200	D200	D300	D201	D301	152	173	290	310	426	447	132	270	407	137	19	25	6,5

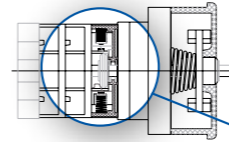
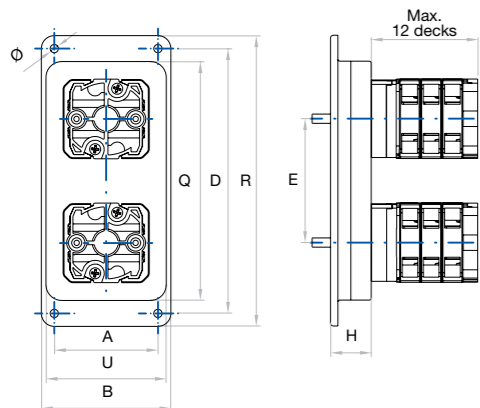

13 14 15 16
H



Push to turn
D401*

Before operating the handle must be pressed to unlock, simultaneously an auxiliary contact it is open or closed (e.g. for switching without load).

Supply	Size	For series
Only incorporated in the cam switch	0	T12-T20-TB20-TB25-TB32
	1	T16-T25-T32-T40

* for arrow handle with indicator, other combinations with special scheme



Locking voltage device
D420

The screw position, left or right, prevents the rotation of the handle.

This device always includes a mounting plate size 1.

Supply	Size	For series
Only incorporated in the cam switch	0-1	T12-T20-TB20-TB25-TB32 TF12-TF16-TF25 T16-T25-T32-T40

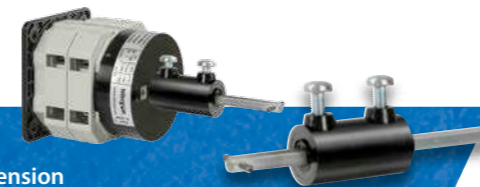
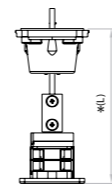

Shaft extension

To extend the shaft length to the depth required. To be complemented with the corresponding D501 device.

Supply	Size	Length (mm)	For series	Code
Spare or incorporated in the cam switch	0-1	200	T12-T20-TB20-TB25-TB32 TF12-TF16-TF25 T16-T25-T32-T40	DT-EPR11
		500		DT-EPR12
Spare or incorporated in the cam switch	2	200	T50-T63	DT-EPR21
		500	T100-T175	DT-EPR22
Only incorporated in the cam switch	3	según pedido	T200	-

*L1 Specify total length when ordering

13 14 15 16
I



One way rotation
D405

This device allows to rotate the handle in only one way.

Supply	Size	For series
Only incorporated in the cam switch	0-1	T12-T20-TB20-TB25-TB32 TF12-TF16-TF25 T16-T25-T32-T40



Clutch device with door interlock
D501

With door interlock in ON position (switch 0-1 to 90°) or according to the electrical diagram.

- 1 Size 0 with padlockable handle included.
- 2 Size 0 - 1 - 2 - 3.

Supply	Size	For series	Code	
Spare	D501 + 704 90°	0	T12-T20 TB20-TB25-TB32 TF12-TF16-TF25	DT-75401N07
			DT-75401R01	
Incorporated in the cam switch	90°	0	T12-T20 TB20-TB25-TB32 TF12-TF16-TF25	DT-50102
				DT-50101
Spare	60°	0-1	T12-T20-TB20-TB25-TB32 TF12-TF16-TF25 T16-T25-T32-T40	DT-50104
				DT-50124
				DT-50134
Spare	45°	0-1	T12-T20-TB20-TB25-TB32 TF12-TF16-TF25 T16-T25-T32-T40	DT-50103
				DT-50123
				DT-50133
Incorporated in the cam switch	90°	2	T50-T63-T100-T175	DT-50121
				DT-50131
Incorporated in the cam switch	90°	3	T200	DT-50122
				DT-50132

Coaxial coupling
D600



Simultaneous operation with only one handle of two or more cam switches (T series) with different ratings coupled together.

Key handle device
D701



Key handle device
D711



D701 Supplied as standard with ø22mm fixing; ø30 mm also available under request.

The key can be locked and removed on request at 60°, 90° or 180°.

Assembly limitation:
4 contacts actuating simultaneously.

D711 Supplied as standard with screw mounting and different types of keys that can be locked and removed at 90°.

Assembly limitation:
4 contacts actuating simultaneously.

Supply	Size	For series
Only incorporated in the cam switch	0	T12-T20-TB20-TB25-TB32 TF12-TF16-TF25
	1	T16-T25-T32-T40

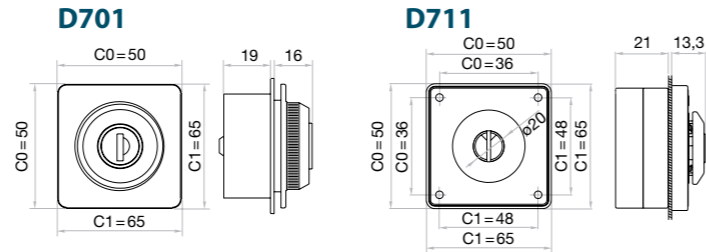

Key lock device
D702



Key lock device with inscription plate
D703



D702 The key lock device allows the adaptation of 1 or 2 auxiliary contacts (1NO + 1NC) operated by turning the key (like signalling or control contacts).

D703 Inscription plate included with text as requested.

Supply	Size	For series
Only incorporated in the cam switch	0-1	T12-T20-TB20-TB25-TB32 TF12-TF16-TF25 T16-T25-T32-T40
	2	T50-T63 T100-T175
	3	T200

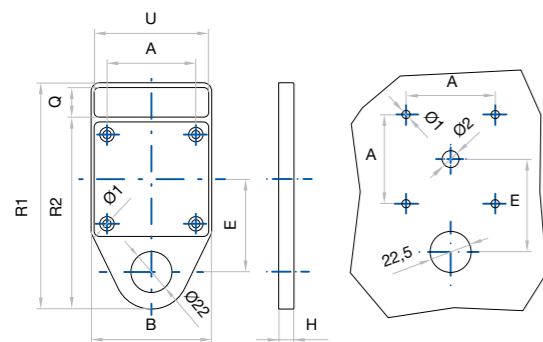

* Auxiliary contacts 1NO + 1NC

Series	B	R1	R2	H	E	U	Q	A	Ø1	Ø2
T12 T20 T16 T25 T32 T40 TB20 TB32 TF12 TF25	65	123	102	6,5	50	61	16	48	4,5	9
T50 T63 T100 T175	94	160	137	7,5	70	90	19	68	5,5	12
T200 T800	132	198	173	10	85	126	21	108	6,5	16

Padlockable handle
D704



- Allows the blockade of the handle in OFF position using padlock.
- Available in red colour on yellow background ¹⁵R or black colour on grey background ¹⁵N
- According to the machinery directive and the european standards, red & yellow handles ¹⁵R are intended to be used only in ON - OFF safety switches.
- For switches O-I specify version ¹⁵R or ¹⁵N, for the rest will be supplied ¹⁵N version (padlocks not included).

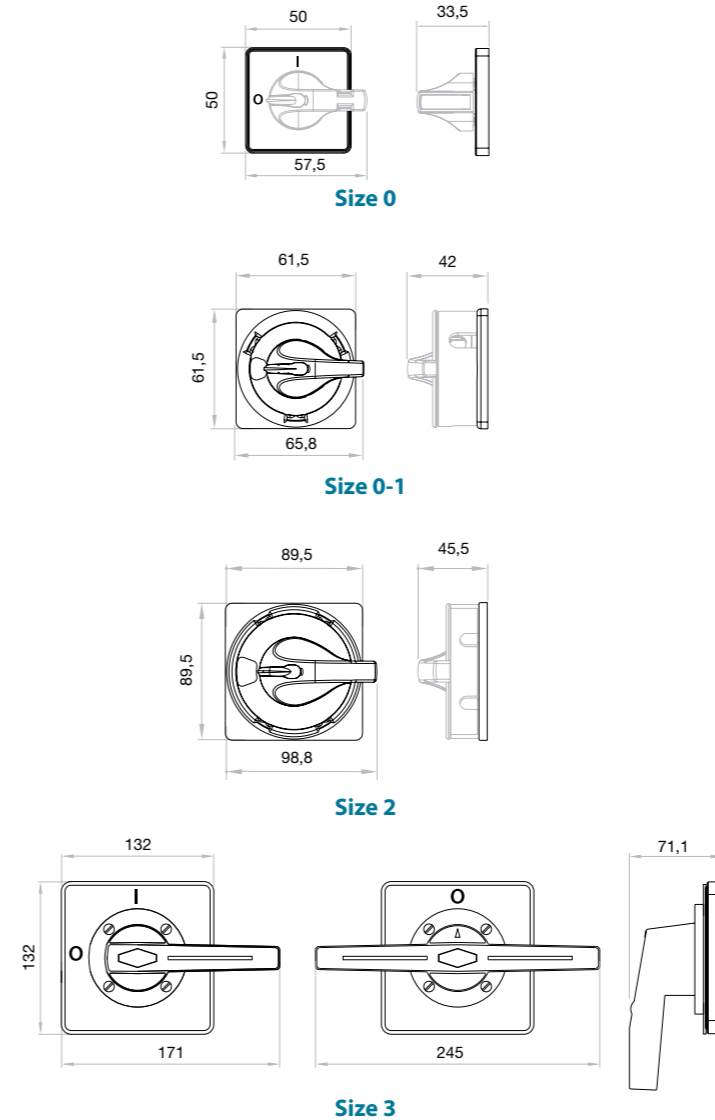

	Supply	Size	For series	Code
Square plate	Spare	0	T12-T20 TB20-TB25-TB32 TF12-TF16-TF25 TP10	DT-70401N07
	Incorporated in the cam switch			DT-70401R01*
Closed view	Spare	0 - 1	T12-T20 TB20-TB25-TB32 TF12-TF16-TF25 T16-T25-T32-T40	DT-7041CN02
	Incorporated in the cam switch			DT-7041CR02
Open view	Spare	0 - 1	T12-T20 TB20-TB25-TB32 TF12-TF16-TF25 T16-T25-T32-T40	DT-7041AN02
	Incorporated in the cam switch			DT-7041AR02
Closed view	Spare	2	T50-T63 T100-T175	DT-7042CN02
	Incorporated in the cam switch			DT-7042CR02
Open view	Spare	2	T50-T63 T100-T175	DT-7042AN02
	Incorporated in the cam switch			DT-7042AR02
Square plate (single handle)	Spare	3	T200	DT-70431
	Incorporated in the cam switch			DT-70433*
Square plate (double handle)	Spare	3	T200	DT-70432
	Incorporated in the cam switch			DT-70434*

*Yellow plate with 0 - 1 positions included

Padlockable handle with inscription plate D705



- Handle can be blocked in OFF position using padlocks.
- Available in red colour on yellow background ¹⁵R or black colour on grey background ¹⁵N
- Inscription plate included with text as requested.
- According to the machinery directive and the european standards, red & yellow handles ¹⁵R are intended to be used only in ON-OFF safety switches.
- For switches O-I specify version ¹⁵R or ¹⁵N, for the rest will be supplied ¹⁵N version (padlocks not included).

	Supply	Size	For series	Code
● Closed view	Only incorporated in the cam switch	0-1	T12-T20	¹³ 14 15 16 7 N 2
			TB20-TB25-TB32	¹³ 14 15 16 7 R 2
○ Open view	Only incorporated in the cam switch		TF12-TF16-TF25	¹³ 14 15 16 C N 2
			T16-T25	¹³ 14 15 16 C R 2
● Closed view	Only incorporated in the cam switch	2	T50-T63	¹³ 14 15 16 7 N 2
			T100-T175	¹³ 14 15 16 7 R 2
○ Open view	Only incorporated in the cam switch		T16-T25	¹³ 14 15 16 C N 2
			T32-T40	¹³ 14 15 16 C R 2
□ Square plate (single handle)	Only incorporated in the cam switch	3	T200	¹³ 14 15 16 N N 2
				¹³ 14 15 16 N R 2
□ Square plate (double handle)	Only incorporated in the cam switch			¹³ 14 15 16 O N 2
				¹³ 14 15 16 O R 2

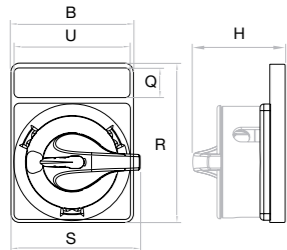

Size	B	H	Q	R	S	U
0-1	6,5	48,5	16	85	65,8	61
2	94	53,5	19	117	98,8	90
3	132	71,5	21	157	171	126

¹⁴ 15 16
D708 ⁸



Push button blocking system D708

D708 Available in two versions (specify when ordering):

- The handle is blocked in all positions.
- The handle is blocked only in OFF position.

The switch in version 2 can be used for emergency operation since the handle is not blocked in ON position. Both versions admit the adaptation of 1 and 2 changeover auxiliary contacts (1NO+1NC), which are activated when the button is pressed and it can be used as signalling and combined operation with contactors.

D709 Inscription plate included with text as requested.

¹⁴ 15 16
D709 ⁹



Push button blocking system with inscription plate D709

Supply	Size	For series
Only incorporated in the cam switch	0-1	T12-T20-TB20-TB25 TB32-TF12-TF16-TF25 T16-T25-T32-T40
	2	T50-T63-T100-T175
	3	T200

* Auxiliary contacts 1NO + 1NC 2NO + 2NC



Series	B	R1	R2	H	E	U	Q	A	Ø1	Ø2
T12 T20 T16 T25 T32 T40 TB20 TB32 TF12 TF25	65	123	102	6,5	50	61	16	48	4,5	9
T50 T63 T100 T175	94	160	137	7,5	70	90	19	68	5,5	12
T200 T800	132	198	173	10	85	126	21	108	6,5	16

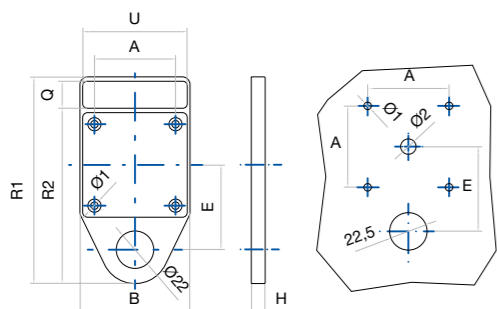

Return from one or two ways up to 120° D802

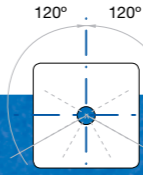

Supply	Size	For series
Only incorporated in the cam switch	0-1	T12-T20-TB20-TB25-TB32 TF12-TF16-TF25 T16-T25-T32-T40

¹⁴ 15 16
E



Terminal shrouds D900

Sizes 0-1 and 2 are supplied as standard with removable protected terminals (IP20).

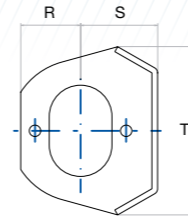

Series	R	S	S
T12 T20	21	27	59
T16 T25 T32 T40	28	34	72
T50 T63 T100	15	52	104
T200	40	155	130

Supply	Size	For series	Code
	0	T12-T20	DT-90002
	1	T16-T25-T32-T40	DT-90012
Spare	2	T50-T63	DT-90022
		T100	DT-90024
	3*	T200	DT-90031
		T400	DT-90032

* Max. 2 chambers

T175 terminal shrouds and phase barriers D900

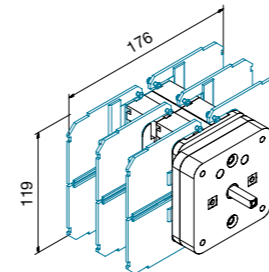

Phase barriers - Vertical
Code DT-90025 (4 units)

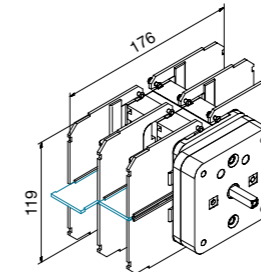

Phase barriers - Horizontal
Code DT-90026 (2 units)

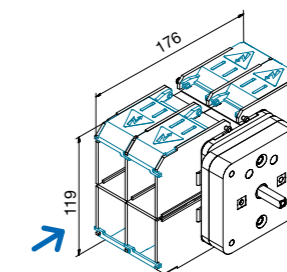

Terminal shrouds (L)
Code DT-90027 (4 units)

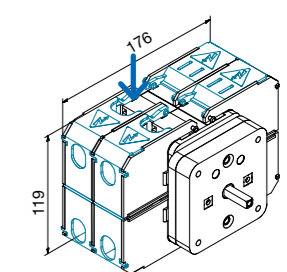

Terminal shrouds (S)
Code DT-90028 (4 units)

DIN rail mounting device D904

D904 Included as standard in D-F-G fixing types for TB-TF and T175 series.

D905 DIN rail mounting with frontal plate and handle for distribution boards.

Front plates for distribution boards D905

Supply	Size	For series	Code
Spare or incorporated in the cam switch	0-1	T12-T20-T16 T25-T32-T40	DT-90401
	2	T50-T63-T100-T175	DT-90421
Only incorporated in the cam switch	0	T12-T20 TF12-TF16-TF25	¹² 13 14 15 16 H 3 N 0

Handles

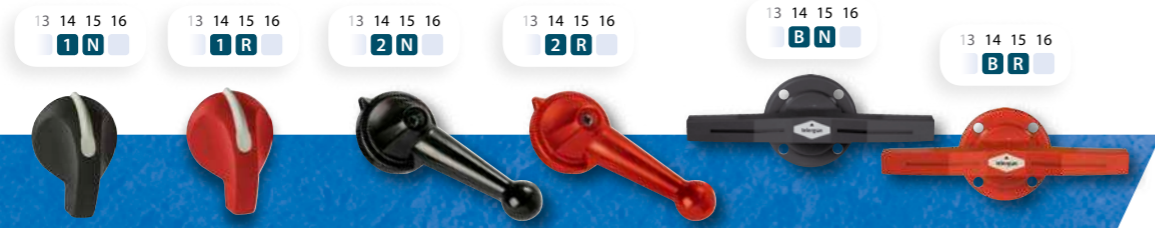

- 14 **1** Arrow handle with indicator.
- 14 **2** Ball lever handle for size 1 and 3.
- 14 **B** Double handle for cam switches size 3.

	Supply	Size	Code		
Arrow handle with indicator	Spare or incorporated in the cam switch	0	● 40110030 ● 40110031		
		1	● 40111034 ● 40111035		
		2	● 40112028 ● 40112029		
		3	● 40113023 ● 40113024		
		Ball lever	Spare or incorporated in the cam switch	1	● 40111002 ● 40111003
				3	● 40113002 ● 40113001
Double handle	Spare or incorporated in the cam switch			3	● 40113008 ● 40113007

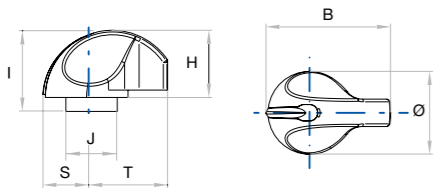

Arrow handle with indicator (sizes 0 - 1 - 2 - 3)

Size	B	H	I	J	S	T	Ø
0	39,3	26,8	30,5	14,5	13,5	24	27
1	50	28	33	14,5	18	32	36
2	66,5	36,5	-	-	22,5	44	45
3	100	54	-	-	38	62	76

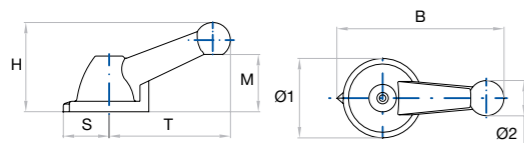

Ball lever (sizes 1 - 3)

Size	B	H	S	T	M	Ø1	Ø2
1	89	48	24	65	32,5	37	18
3	151,5	81	41,5	110	52	72	32

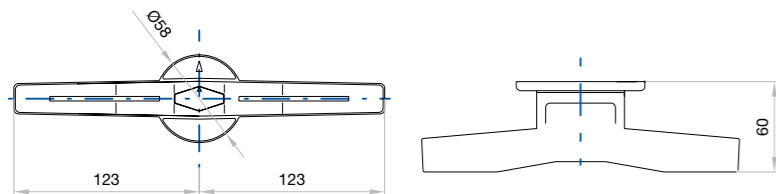

Double handle (size 3)

Neutral name plates and neutral inscription plates



- Plastic indicating plate on square base with black engraving
- Also in yellow colour available (emergency handle).
- Different engravings are available under request.
- PPA model with inscription plate.

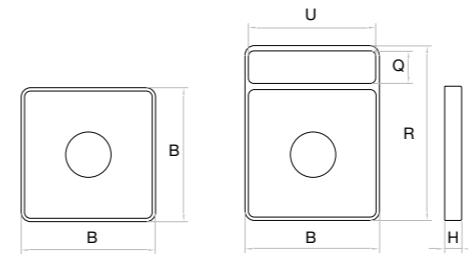

PPA

PRA

Size	B	R	H	U	Q
0	50	65	6,5	47	11
1	65	85	6,5	61	16
2	94	117	7	90	19
3	132	157	10	126	21

	Supply	Size	Code
PPA (neutral plate)	Spare or incorporated in the cam switch	0	■ 40140045 ■ 40140061 ■ 40110028
		1	■ 40141039 ■ 40141053 ■ 40111032
		2	■ 40142020 ■ 40142028 ■ 40142025
		3	■ 40143020 ■ 40143028 ■ 40143084
PRA (neutral plate)	Spare or incorporated in the cam switch	0	■ 40140203 ■ 40110029
		1	■ 40141188 ■ 40111033
		2	■ 40142095 ■ 40112026
		3	■ 40143088 ■ 40143086

Terminal extensions CP

Supply	Size	For series
Only incorporated in the cam switch	0	T12-T20
	1	T16-T25-T32-T40
	2	T50-T63-T100

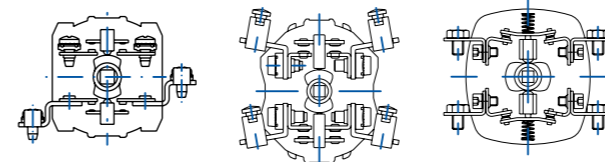

T12-T16-T20-T25

T32-T40-T63-T100

T200 standard connection as per drawing

Fast-on terminals 6,25 x 0,8

Supply	Size	For series
Only incorporated in the cam switch	0-1	T12-T20 T16-T25-T32-T40



TP | T | TB | TF Standard diagrams

For many switching operations that can be resolved using cam switches, we have a number of standard schemes applicable to the most common applications in electrical installations, equipment, machinery, etc. If you do not find what you are looking for in this selection, or have a special switching requirement, you can use the blank diagrams form on the next page and send it to our sales department. The descriptive logic representing and interpreting the circuits are explained below.

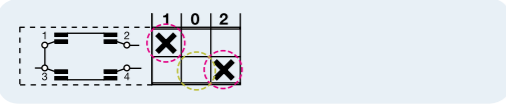

It represents "closed contact".

It represents "opened contact".

The contact 1/2 is closed in position 1 and opened in positions 0 & 2.

The contact 3/4 is closed in position 2 and opened in positions 0 & 1.

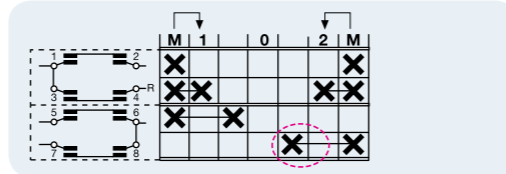

They represent "late break contact" or "early-make contact" in relation to others.

The contacts 5/6 & 7/8 close before the contacts 3/4 & 1/2 and they will also open after these contacts.

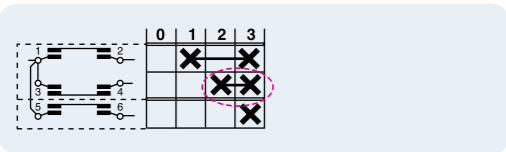

It represents closed contact "without interruption".

The contact 1/2 closes in position 1, and remains closed in position 2 & 3.

The contact 3/4 closes in position 2 and remains closed in position 3.

When passing from one position to another there is no contact interruption in any cases.

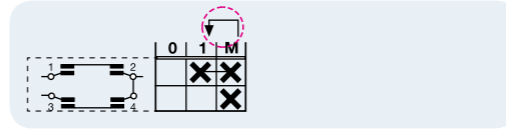

It represent "spring return" to previous position.

The M position is not fixed and it will return to position 1 when the handle is released.

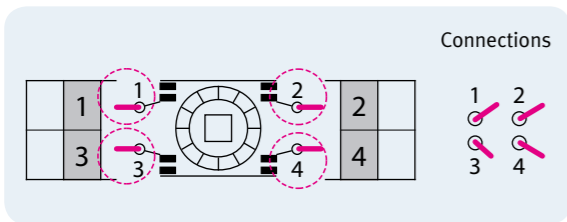

Connection point.

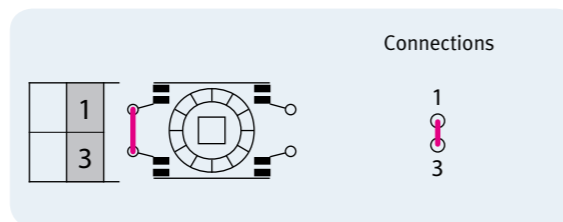

Vertical bridging link.

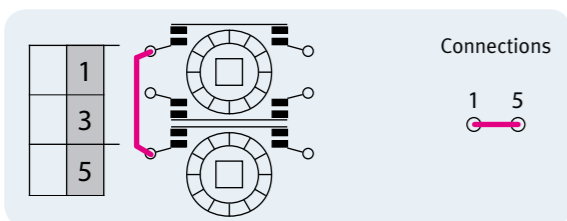

Horizontal bridging link.

Inscription plate
Name plate

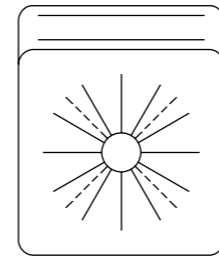

ORDER SHEET FOR NON-STANDARD CAM SWITCHES 10 TO 200 AMP.



Series

Code

- Contact closed
- Closed contact without interruption
- Late break contact
- Early-make contact
- Return from 30°

Rev.

Number of switch positions

1		2	
3		4	
5		6	
7		8	
9		10	
11		12	
13		14	
15		16	
17		18	
19		20	
21		22	
23		24	
25		26	
27		28	
29		30	
31		32	
33		34	
35		36	
37		38	
39		40	
41		42	
43		44	
45		46	
47		48	

Connections

1	5	9	13	17	21	25	29	33	37	41	45
○	○	○	○	○	○	○	○	○	○	○	○
○	○	○	○	○	○	○	○	○	○	○	○
3	7	11	15	19	23	27	31	35	39	43	47
○	○	○	○	○	○	○	○	○	○	○	○
○	○	○	○	○	○	○	○	○	○	○	○
46	42	38	34	30	26	22	18	14	10	6	2
○	○	○	○	○	○	○	○	○	○	○	○
○	○	○	○	○	○	○	○	○	○	○	○
48	44	40	36	32	28	24	20	16	12	8	4

T series

0	12	20			
1	16	25	32	40	
2	50	63	80	100	125
3	200	250	315	400	500

TB series

20	25	32	40
----	----	----	----

TF series

12	16	25	32	40
----	----	----	----	----

TP series

10

Type

E	C	Z	D	G	H	F
---	---	---	---	---	---	---

Handle

Indicator arrow	Black	Shaft extension mm
Ball lever handle	Red	
Double handle	Yellow	
Key	Keya	Kaba mini

Nameplate

Aluminium colour	Normal
Yellow colour	With inscription
Switching angle 30° -45° -60° -90°	

Materials

Chambers

Notes

Validity

Date

Signature

Special devices

On-Off switches

010 1 pole 1 chamber	010/5 5 poles	010/10 10 poles	010/15 15 poles	010/20 20 poles
010/6 6 poles	010/11 11 poles	010/16 16 poles	010/21 21 poles	010/26 26 poles
010/7 7 poles	010/12 12 poles	010/17 17 poles	010/22 22 poles	010/27 27 poles
010/8 8 poles	010/13 13 poles	010/18 18 poles	010/23 23 poles	010/28 28 poles
010/9 9 poles	010/14 14 poles	010/19 19 poles	010/24 24 poles	

To view these wiring diagrams please visit our download area on www.telergon.com

On-Off switches with contacts leading when making

020 3 poles 1 preclosed pole 2 chambers	021 4 poles 1 preclosed pole 2 chambers	022 4 poles 3 preclosed poles 2 chambers
--	--	---

Reversing switches

101 2 poles 2 chambers

Reversing switches

102 3 poles 3 chambers

Reversing switches with spring return

111 2 poles 2 chambers	112 3 poles 3 chambers	113 3 poles for use with reserving contactors 4 chambers
-------------------------------------	-------------------------------------	--

Control switches with spring return

201 Start switch 1 pole 1 chamber	202 Stop switch 1 pole 1 chamber	203 Start switch 2 poles 1 chamber	204 Stop switch 2 poles 1 chamber
--	---	---	--

Stop-Start switches

205 With contactor 1 chamber	206 With contactor and spring return 1 chamber	207 With spring return to run for 2 units 2 chambers
---	---	---

Start delta switches

300 Normal type 4 chambers	301 Auxiliary contact closed in "0" 5 chambers	302 Reversing 5 chambers	303 Rotary 0-λ-Δ-0-λ-Δ-0 5 chambers	304 Position λ return to 0 0-λ-Δ 4 chambers	305 Reversing. Return from λ to 0 Δ-λ-0-λ-Δ 5 chambers	308 Use with contactor 0-λ-Δ 4 chambers	309 Reversing for use with contactor Δ-λ-0-λ-Δ 7 chambers
---	---	---------------------------------------	---	---	--	---	---

To view these wiring diagrams please visit our download area on www.telergon.com

Start delta switches

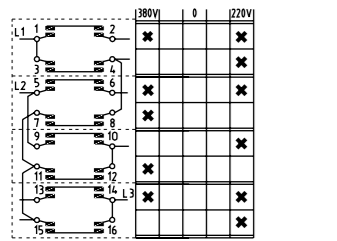
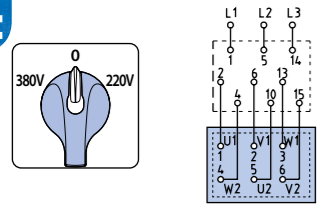

310
Selector $\lambda - \Delta$
380 - 0 - 220
4 chambers

Split phase starting switches

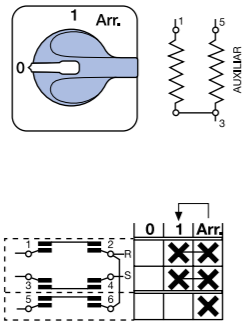

315
Start return to 1
2 chambers

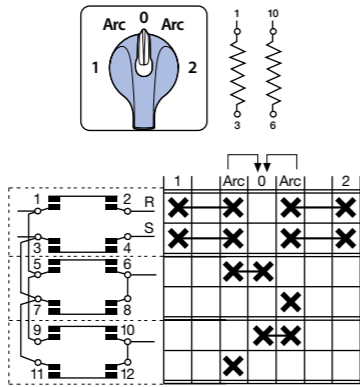

316
Reversing type of T315
1 - ARR - 0 - ARR - 2
3 chambers

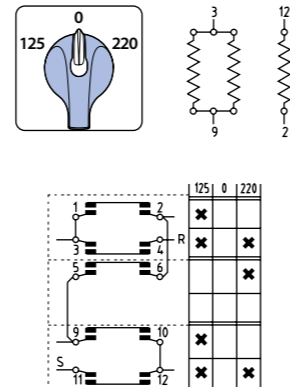

317
Start single phase 2 voltages
3 chambers

Dahlander multi-step switches

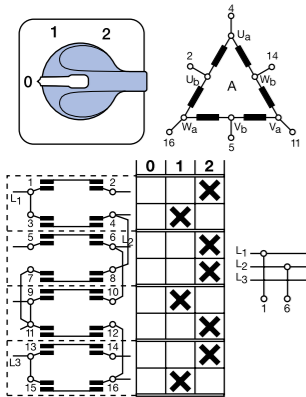

330
Dahlander $0 - \Delta_A - \lambda \lambda_A$
4 chambers

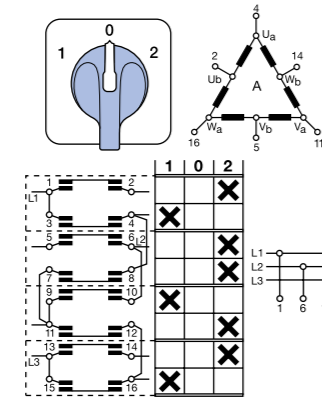

331
Dahlander $\Delta_A - 0 - \lambda \lambda_A$
4 chambers

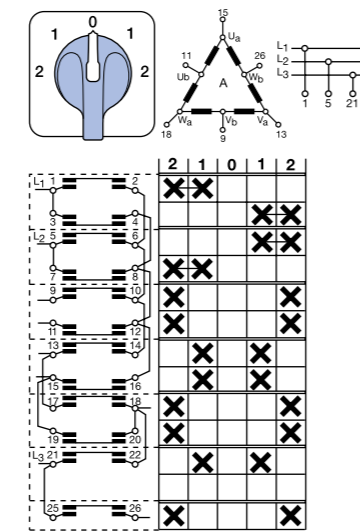

332
Reversing type of T330
7 chambers

333
Dahlander $0 - \Delta_A - \lambda \lambda_A - 0 - \Delta_A - \lambda \lambda_A - 0$
0 - 1 - 2 - 0 - 1 - 2
5 chambers
334
For use with contactor
0 - 1 - 2
5 chambers
335
Selector Dahlander
 $0 - \lambda - \Delta_A - \lambda \lambda_A$
6 chambers
336
Reversing Dahlander
 $\lambda \lambda_A - \Delta_A - \lambda - 0 - \lambda - \Delta_A - \lambda \lambda_A$
2 - 1 - λ - 0 - λ - 1 - 2
8 chambers

To view these wiring diagrams please visit our download area on www.telergon.com

Separate winding to speed

340
 $0 - \lambda_A - \Delta - \lambda_B$
 $0 - \lambda - 1 - 2$
6 chambers
341
 $0 - \Delta_A - \lambda_B$
 $0 - 1 - 2$
4 chambers

342
 $0 - A - B$ en λ or Δ
 $0 - 1 - 2$
3 chambers
343
Reversing del 342
 $2 - 1 - 0 - 1 - 2$
5 chambers

344
 $\Delta_B - \lambda_B - 0 - \lambda_A - \Delta_A$
 $1 - \lambda - 0 - \lambda - 2$
8 chambers
350
 $0 - \lambda_A - \Delta_B - \lambda \lambda_B$
 $0 - 1 - 2 - 3$
6 chambers

351
Reversing type of T350
 $3 - 2 - 1 - 0 - 1 - 2 - 3$
9 chambers

To view these wiring diagrams please visit our download area on www.telergon.com

Changeover switches with center "Off"

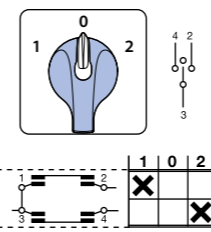

400
1 pole
1 chamber

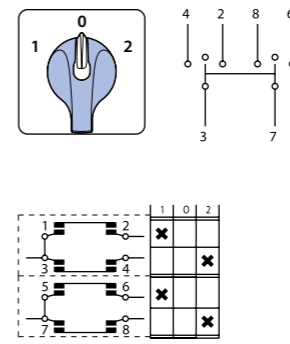

401
2 poles
2 chambers

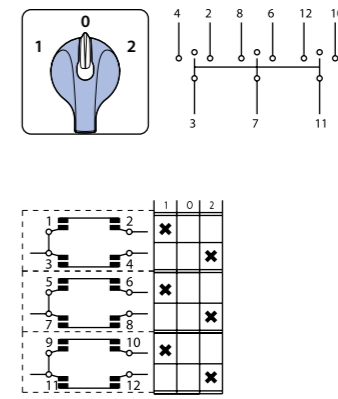

402
3 poles
3 chambers

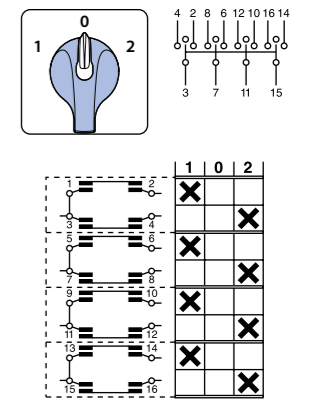

403
4 poles
4 chambers

	Poles	Positions	Chambers		Poles	Positions	Chambers		Poles	Positions	Chambers		Poles	Positions	Chambers				
400/5	5	3	5	00400	400/7	7	3	7	00401	400/9	9	3	9	00402	400/11	11	3	11	00403
400/6	6	3	6	00310	400/8	8	3	8	00404	400/10	10	3	10	00405	400/12	12	3	12	00406

To view these wiring diagrams please visit our download area on www.telergon.com

Changeover switches with spring return to center

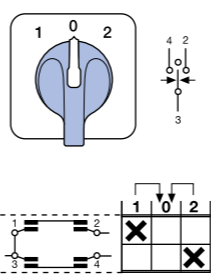

405
1 pole
1 chamber

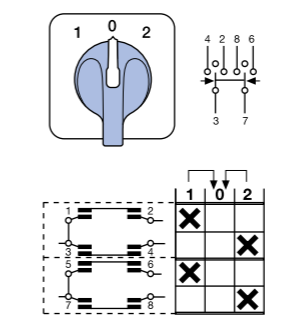

406
2 poles
2 chambers

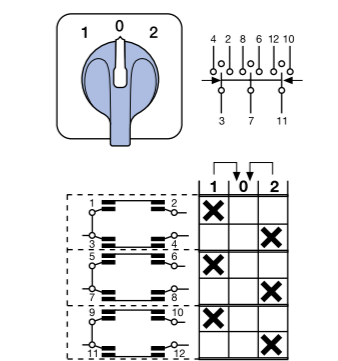

407
3 poles
3 chambers

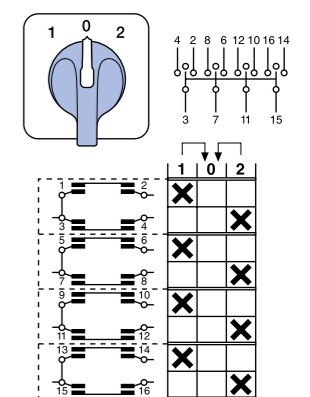

408
4 poles
4 chambers

Multi-step switches with "Off" position

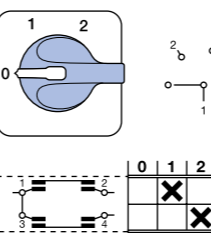

410
1 pole 2 positions
1 chamber

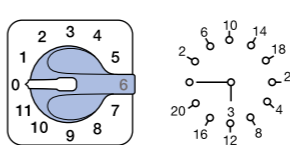

419
1 pole 11 positions
6 chambers

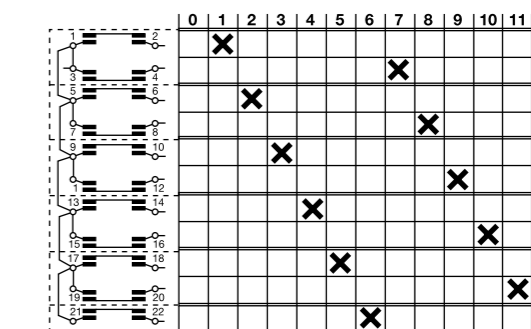

Multi-step switches with "Off" position

	Poles	Positions	Chambers		Poles	Positions	Chambers		Poles	Positions	Chambers		Poles	Positions	Chambers
411	1	3	2	422	2	4	4	432	3	4	6	452	5	4	10
412	1	4	2	423	2	5	5	433	3	5	9	460	6	2	6
413	1	5	3	424	2	6	7	434	3	6	12	461	6	3	9
414	1	6	4	425	2	7	8	435	3	7	12	462	6	4	12
415	1	7	4	426	2	8	9	440	4	2	4	470	7	2	7
416	1	8	5	427	2	9	10	441	4	3	6	471	7	3	11
417	1	9	5	428	2	10	11	442	4	4	8	480	8	2	8
418	1	10	6	429	2	11	12	443	4	5	10	481	8	3	12
420	2	2	2	430	3	2	3	450	5	2	5	490	9	2	9
421	2	3	3	431	3	3	5	451	5	3	8				

To view these wiring diagrams please visit our download area on www.telergon.com

Changeover switches without "Off"

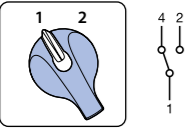
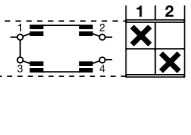
500
1 pole
1 chamber

501
2 poles
2 chambers

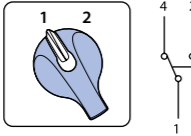
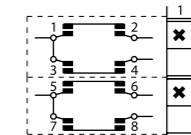
502
3 poles
3 chambers



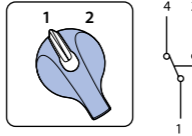
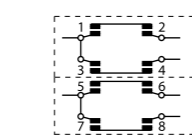

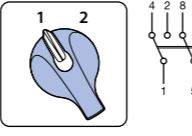
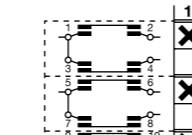
503
4 poles
4 chambers

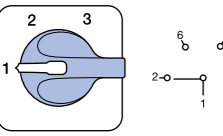
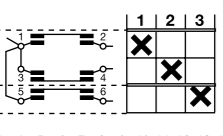

Poles	Positions	Chambers	Poles	Positions	Chambers	Poles	Positions	Chambers	Poles	Positions	Chambers				
500/5	5	2	5	500/7	7	2	7	500/9	9	2	9	500/11	11	2	11
500/6	6	2	6	500/8	8	2	8	500/10	10	2	10	500/12	12	2	12

To view these wiring diagrams please visit our download area on www.telergon.com

Multi-step switches without "Off" position

510
1 pole 3 positions
2 chambers

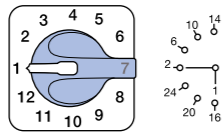
519
1 pole 12 positions
6 chambers

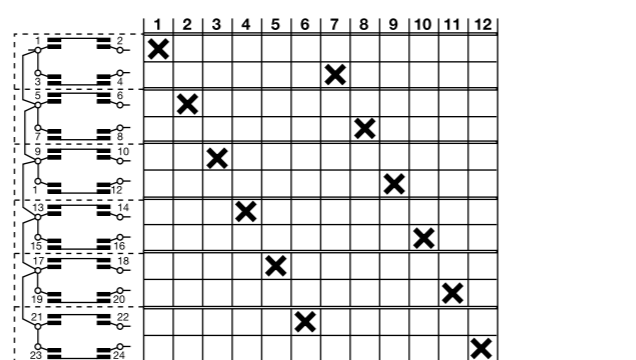

Multi-step switches without "Off" position

	Poles	Positions	Chambers		Poles	Positions	Chambers		Poles	Positions	Chambers		Poles	Positions	Chambers
511	1	4	2	521	2	4	4	530	3	3	5	543	4	6	12
512	1	5	3	522	2	5	5	531	3	4	6	550	5	3	8
513	1	6	3	523	2	6	6	532	3	5	8	551	5	4	10
514	1	7	4	524	2	7	7	533	3	6	9	552	5	5	13
515	1	8	4	525	2	8	8	534	3	7	11	560	6	3	9
516	1	9	5	526	2	9	9	535	3	8	12	561	6	4	12
517	1	10	5	527	2	10	10	540	4	3	6	570	7	3	11
518	1	11	6	528	2	11	11	541	4	4	8	580	8	3	12
520	2	3	3	529	2	12	12	542	4	5	10				

To view these wiring diagrams please visit our download area on www.telergon.com

Gang switches

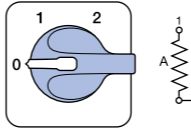
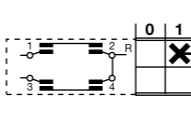
601
1 pole switching sequence
0 - A - (A+B)
1 chamber

602
2 poles switching sequence
0 - A - B - (A+B)
2 chambers

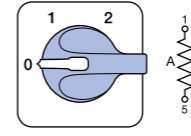
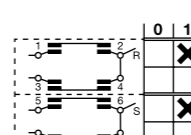
603
1 pole switching sequence
0 - A - B - (A+B)
1 chamber

604
2 poles switching sequence
0 - A - B - (A+B)
2 chambers

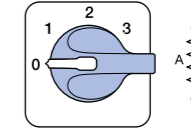
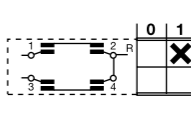
605
1 pole switching sequence
0 - A - (A+B) - (A+B+C)
2 chambers

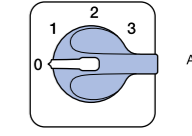
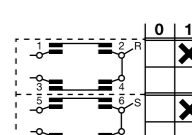
606
2 poles switching sequence
0 - A - (A+B) - (A+B+C)
3 chambers

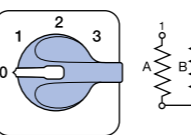
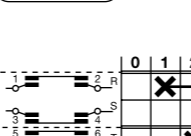
607
3 poles switching sequence
0 - A - (A+B)
3 chambers

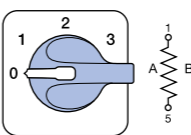
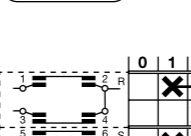
608
3 poles switching sequence
0 - A - B - (A + B)
3 chambers

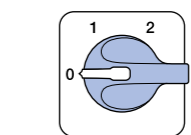
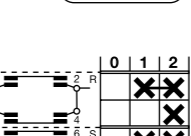
Gang switches

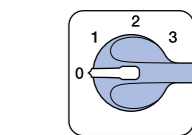
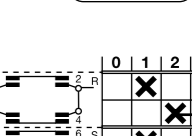
609
3 poles switching sequence
0 - A - (A+B) - (A+B+C)
5 chambers

610
Switching sequence
 λ 0 - A - (A+B) - (A+B+C)
2 chambers

611
Switching sequence
 Δ 0 - A - (A+B) - (A+B+C)
2 chambers

612
Switching sequence 0 - A + B series
A - B - (A + B) paralell
2 chambers

Kitchen and heating switches

613
3 positions switching sequence
0-A+B paralell; A or B-A+B series -0
3 chambers

614
3 positions switching sequence
0-A+B series; A or B-A+B paralell
2 chambers

Resistance elimination switches

620
3 phases, 3 points
2 chambers

621
3 phases, 3 points
3 chambers
With auxiliary contact

622
3 phases, 4 points
3 chambers

624
3 phases, 5 points
4 chambers

626
3 phases, 6 points
5 chambers

630
Switching sequence
0 - A - (A+B) - (A+B+C)
2 chambers

631
Switching sequence
0 - A - (A+B) - (A+B+C) - (A+B+C+D)
2 chambers

632
Switching sequence
0 - A - (A+B) - (A+B+C) - (A+B+C+D) - (A+B+C+D+E)
3 chambers

Voltmeter switches

700
2 phases C.A. or 2 poles C.C.
2 chambers

701
3 phases
2 chambers

702
3 phases to neutral
2 chambers

704
3 phases and 1 phase to neutral
3 chambers

703
4 lines with 2 wires C.A. o C.C.
4 chambers

705
3 phases a phase and 3 phases to neutral
3 chambers

706
2 líneas trifásicas (phase to phase)
4 chambers/chambers

Tabla equivalencias
11=1L1
12=1L2
13=1L3
21=2L1
22=2L2
23=2L3

Ammeter switches

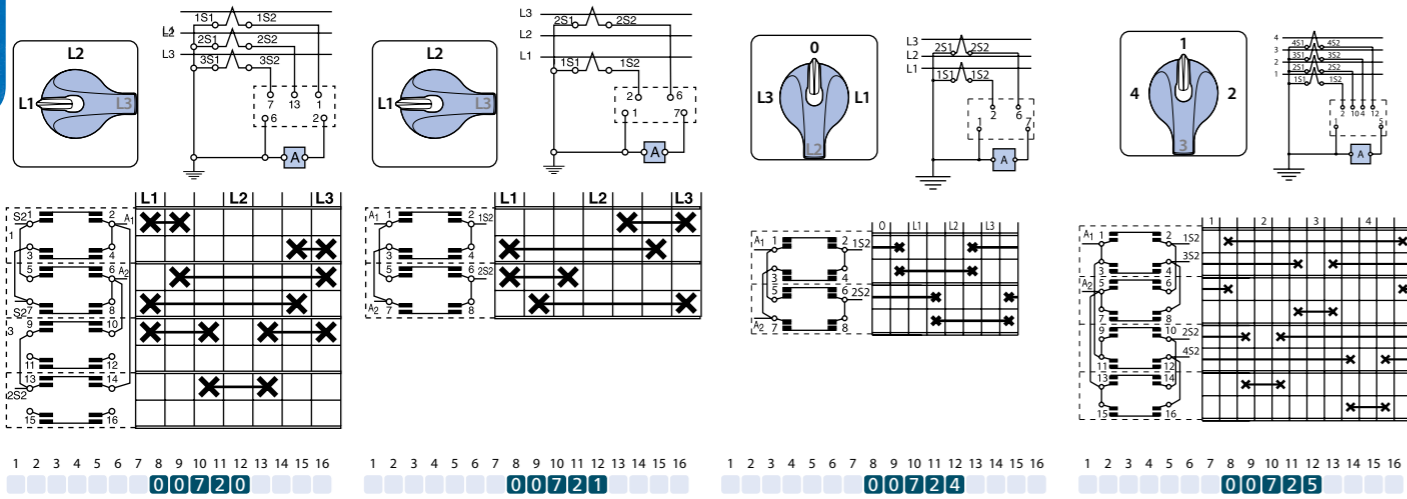

00720 00721 00724 00725

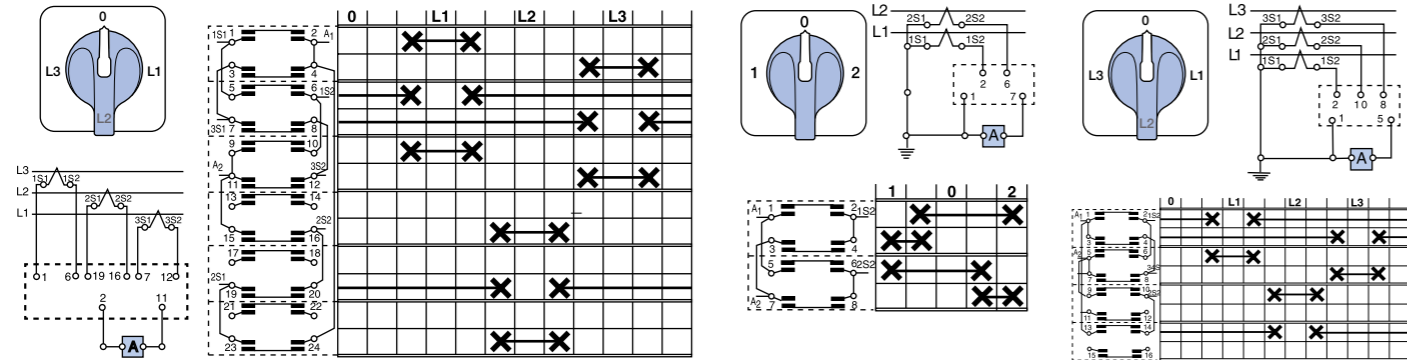

00727 00730 00731

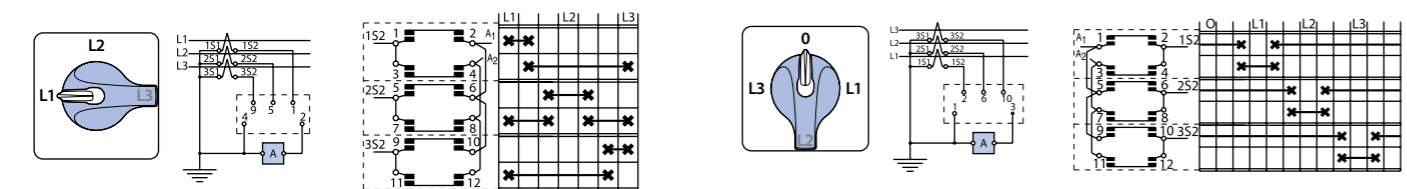

00732 00733 00733

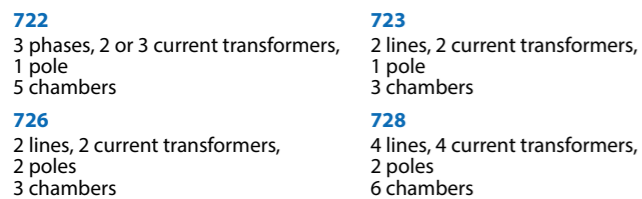

To view these wiring diagrams please visit our download area on www.telergon.com

Switches for B.C.D. codification with "Off"

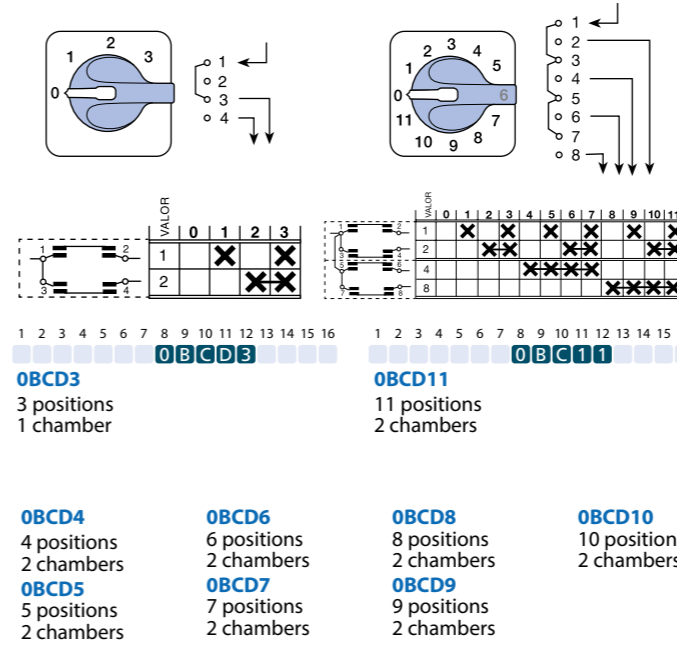

To view these wiring diagrams please visit our download area on www.telergon.com

Switches for B.C.D. codification without "Off"

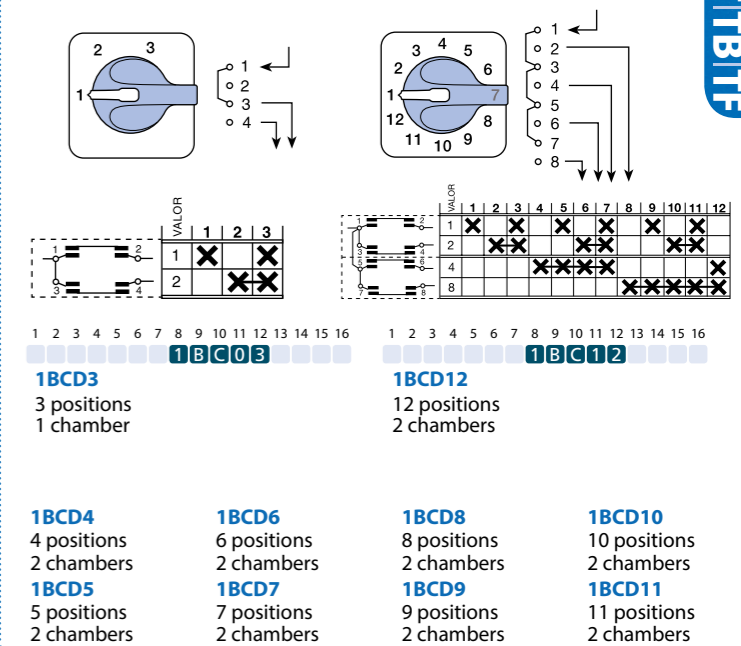

By-pass switches

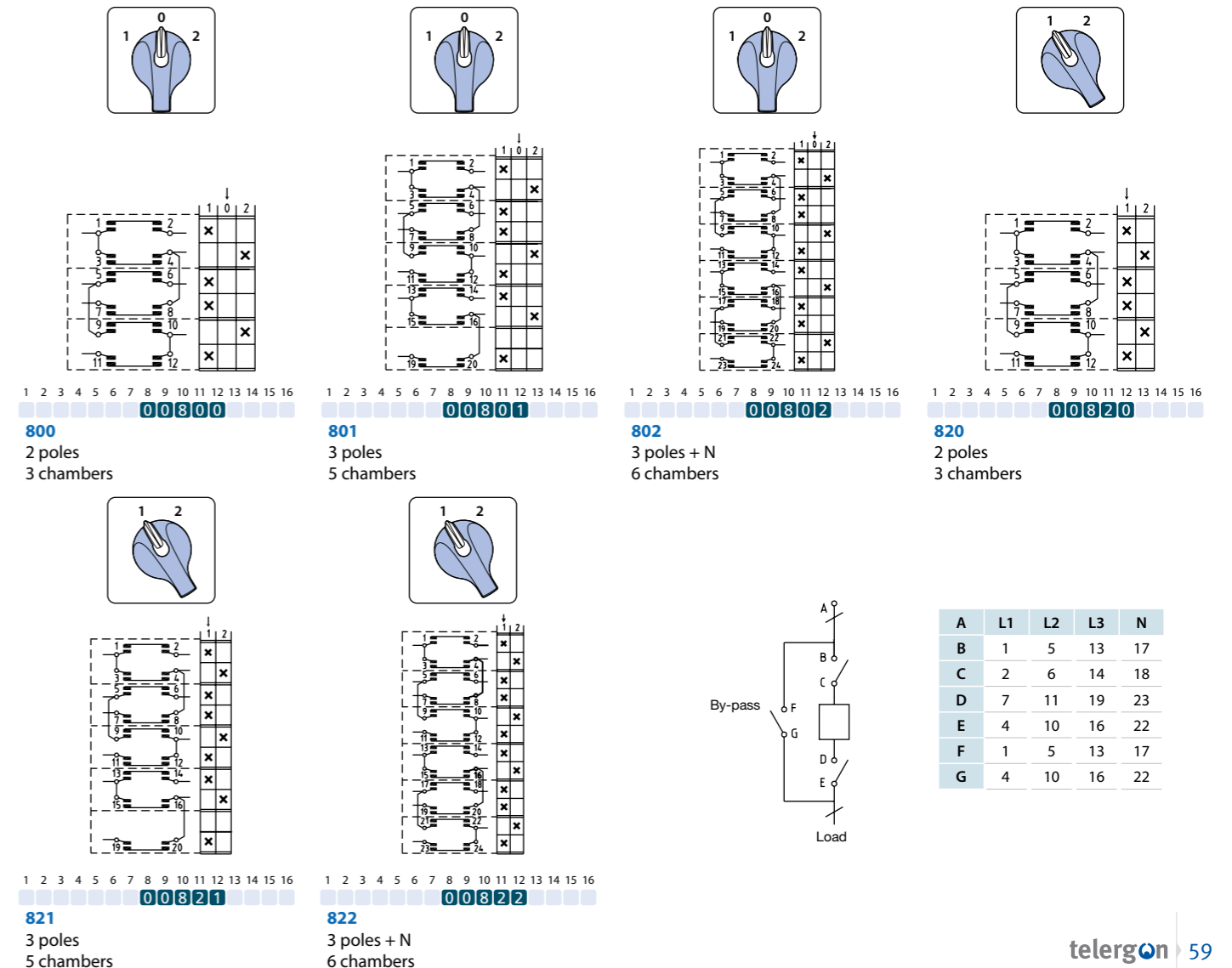

AC Modular switch - disconnectors and changeover switches

series
ZBK

Modular switch – disconnectors and changeover switches of reduced size, available in different fixation types with a wide range of currents and a variety of accessories.

According to:
VDE 0660, IEC/EN 60947-3, IEC/EN 60947-5-1
UL & cUL
RoHS



Testing and approvals:

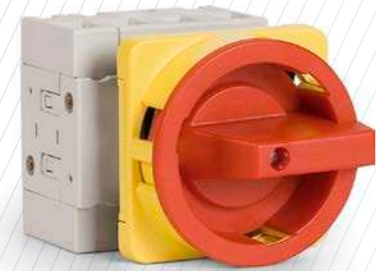

The ZBK switch - disconnectors are 3, 4, 6 and 8-pole modular devices with a high breaking capacity and contact pressure, which respond well to short circuits. They are designed for use in low voltage civil and industrial machines and facilities and made of different models depending on the type of mounting. Manufactured under strict quality controls to provide a reliable product that meets the most demanding requirements.

The ZBK series also includes a range of 1-0-2 changeover switches plus applications with plastic enclosures and various accessories.

ZBK O-I



Door mounting fixing by screws.
Two sizes of padlockable handles .
Auxiliary terminals and other accessories.



Base mounting fixing by screws or DIN rail and handle $\varnothing 22$
Two sizes of padlockable handles .
Shaft extension depth-adjustable.
Auxiliary terminals and other accessories.

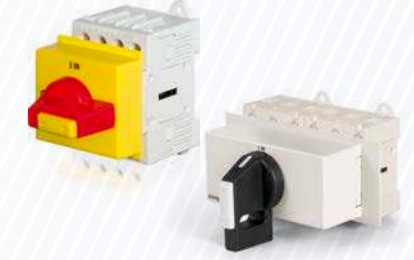

Base mounting fixing by screws or DIN rail.
Direct handle (modular) with lock .
Auxiliary terminals and other accessories.

ZBK I-O-2



Modular switch in plastic enclosure (sealable).
Padlockable handles .



Base mounting fixing by screws or DIN rail.
Direct handle (modular) with lock .
Supplied with bridging links included.
Auxiliary terminals and other accessories.

Range coding:

The ZBK series, are identified by a code that describes their most important characteristics as described below

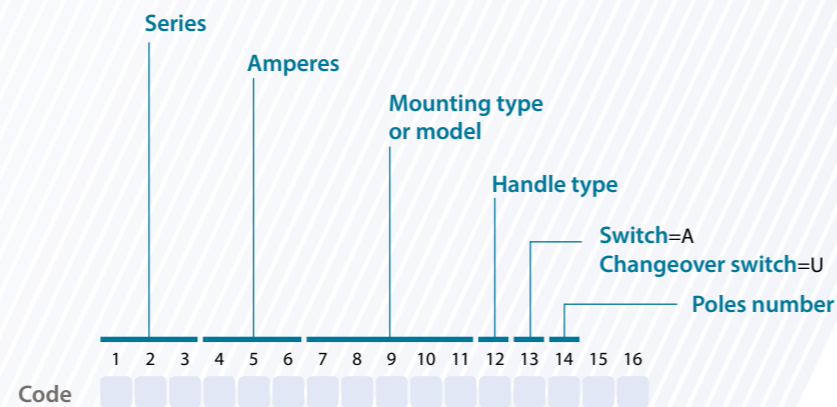

Accessories



Auxiliary contacts



PE - Terminal



N - Terminal



N - Terminal immovable

ZBK

Switch door mounting with padlockable handle IP66

3P - 3P+N

Size 0

A 20|25|40|63|80|125



		CODE - 20A	CODE - 25A	CODE - 40A	CODE - 63A	CODE - 80A	CODE - 125A
64	3P	ZBK20EHN4A3	ZBK25EHN4A3	ZBK40EHN4A3	ZBK63EHN4A3	ZBK80EHN4A3	ZBK125EHN4A3
	3P + N	ZBK20EHN4A4	ZBK25EHN4A4	ZBK40EHN4A4	ZBK63EHN4A4	ZBK80EHN4A4	ZBK125EHN4A4
48	3P	ZBK20EH4A3	ZBK25EH4A3	ZBK40EH4A3	ZBK63EH4A3	ZBK80EH4A3	ZBK125EH4A3
	3P + N	ZBK20EH4A4	ZBK25EH4A4	ZBK40EH4A4	ZBK63EH4A4	ZBK80EH4A4	ZBK125EH4A4
64	3P	ZBK20EHN1A3	ZBK25EHN1A3	ZBK40EHN1A3	ZBK63EHN1A3	ZBK80EHN1A3	-
	3P + N	ZBK20EHN1A4	ZBK25EHN1A4	ZBK40EHN1A4	ZBK63EHN1A4	ZBK80EHN1A4	-
48	3P	ZBK20EH1A3	ZBK25EH1A3	ZBK40EH1A3	ZBK63EH1A3	ZBK80EH1A3	-
	3P + N	ZBK20EH1A4	ZBK25EH1A4	ZBK40EH1A4	ZBK63EH1A4	ZBK80EH1A4	-

Technical information



According to VDE 0660, IEC/EN 60947-3, IEC/EN 60947-5-1

			20	25	40	63	80	125	
Rated thermal current	Ith	A	20	25	40	63	80	125	
Rated thermal current enclosed	Ithe	A	20	25	40	63	80	110	
Rated insulation voltage	Ui	V	690	690	690	690	690	1000	
Rated impulse withstand voltage	Uimp	kV	6	6	6	6	6	8	
AC rated operational current	Ie	AC21A	A	20	25	40	63	80	125
Making capacity	Ieff	3x380-440V	A	160	190	300	370	440	850
Breaking capacity		3x220-240V	A	160	180	250	330	380	680
		3x380-440V	A	160	180	250	330	380	680
Direct switching motors	AC3	3x660-690V	A	80	110	170	190	220	420
		3x400V	A	12	16	30	37	37	72
Main & safety switch	AC23	3x220-240V	kW	3	4	7,5	11	11	22
		3x380-440V	kW	5,5	7,5	15	18,5	18,5	37
		3x660-690V	kW	5,5	7,5	15	18,5	18,5	30
		3x660-690V	kW	5,5	7,5	15	18,5	18,5	37
Rated conditional short-circuit current	kAeff		10	10	10	10	10	10	
Max. fuse size	gL(gG)	A	25	35	50	63	80	125	
Rated short-time withstand current (1sec. current)	Icw	A	250	300	500	600	850	1500	
Mechanical life		x10 ³	200	200	200	100	100	100	
Connecting capacity									
Solid or stranded cable	mm ²		0,5-10		1-25 *(1)		4-50		
		AWG	20-8 (10)		16-4 (10)		10-0 (10)		
Flexible cable	mm ²		0,5-6		4-16 *(1)		10-35		
		AWG	20-10		16-6		8-2		
Size of terminal screw			M3,5		M5		M6		
Tightening torque	Nm		0,8-1,7		2-4		3,5-4,5		

According to UL & cUL FILE NO. E123623

			20	25	40	63	80	125
Rated voltage	V		600	600	600	600	600	600
Ampere-Rating "General use"	A		20	25	40	63	80	125
DOL-Rating 3-phase	HP	110-220V	1	1,5	2	3	5	15
		220-240V	3	5	5	10	10	30
		440-480V	7,5	10	10	20	20	60
		550-600V	10	10	15	25	25	60
DOL-Rating 1-phase	HP	110-120V	1	1	1	2	2	7,5
		200-208V	1	2	2	3	3	10
		220-240V	2	2	3	5	5	15
Fuse size (RK5)	A		40	50	70	90	110	125
5kA / 600V	A		40	50	50	70	70	125
Tightening torque	Nm		1,2-2,3	1,2-2,3	1,2-2,3	2,8-4	2,8-4	1,7-4,5
		lb.Inch	11-20	11-20	11-20	24-35	24-35	15-40

*(1) ZBK63__U trenzado 16 mm² / flexible 10 mm²

Accessories



Auxiliary contacts

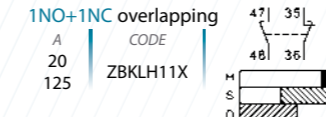

PE - Terminal



N - Terminal



N - Terminal immovable



Auxiliary contacts technical information

Rated insulation voltage	Ui	V	690
Rated thermal current	Ith - Ithe	A	10
Switching capacity	AC15	220-240V	A 2,5
	AC15	380-440V	A 1,5
Rated conditional short-circuit current		kAeff	3
Max. short circuit protection	gL(gG)	A	10

Connecting capacity

Solid or stranded cable	mm ²	0,75-2,5
	AWG	14-12
Flexible cable (+ multicore cable end)	mm ²	0,75-2,5 (1,5)
	AWG	18-14

Dimensions (mm)

Panel drilling for panel handle

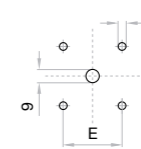
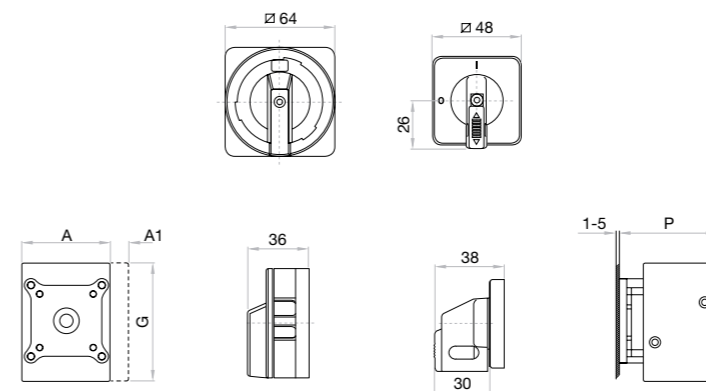

	3P		4P		
	A	A	E	G	P
20-80 A □48	48	62,5	36	64	54
20-80 A □64	48	62,5	48	64	54
125 A □64	78	78	48	85	60

Auxiliary contacts A1

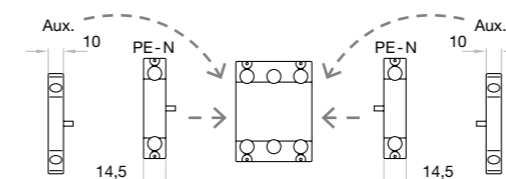

» Other options also available on request:
- Products panel mounting fixing ø 22
- Terminal shrouds

ZBK

Switch base mounting $\varnothing 22$ door clutch padlockable handle IP66

3P - 3P+N

Size 0

A 20|25|40|63|80|125



		CODE - 20A	CODE - 25A	CODE - 40A	CODE - 63A	CODE - 80A	CODE - 125A
64	3P	ZBK20VZVHN4A3	ZBK25VZVHN4A3	ZBK40VZVHN4A3	ZBK63VZVHN4A3	ZBK80VZVHN4A3	ZBK125VZVHN4A3
	3P + N	ZBK20VZVHN4A4	ZBK25VZVHN4A4	ZBK40VZVHN4A4	ZBK63VZVHN4A4	ZBK80VZVHN4A4	ZBK125VZVHN4A4
48	3P	ZBK20VZVH4A3	ZBK25VZVH4A3	ZBK40VZVH4A3	ZBK63VZVH4A3	ZBK80VZVH4A3	ZBK125VZVH4A3
	3P + N	ZBK20VZVH4A4	ZBK25VZVH4A4	ZBK40VZVH4A4	ZBK63VZVH4A4	ZBK80VZVH4A4	ZBK125VZVH4A4
64	3P	-	ZBK25VZVHN1A3	ZBK40VZVHN1A3	ZBK63VZVHN1A3	ZBK80VZVHN1A3	ZBK125VZVHN1A3
	3P + N	-	ZBK25VZVHN1A4	ZBK40VZVHN1A4	ZBK63VZVHN1A4	ZBK80VZVHN1A4	ZBK125VZVHN1A4
48	3P	-	ZBK25VZVH1A3	ZBK40VZVH1A3	ZBK63VZVH1A3	ZBK80VZVH1A3	ZBK125VZVH1A3
	3P + N	-	ZBK25VZVH1A4	ZBK40VZVH1A4	ZBK63VZVH1A4	ZBK80VZVH1A4	ZBK125VZVH1A4

Technical information



According to VDE 0660, IEC/EN 60947-3, IEC/EN 60947-5-1

			20	25	40	63	80	125		
Rated thermal current	Ith	A	20	25	40	63	80	125		
Rated thermal current enclosed	Ithe	A	20	25	40	63	80	110		
Rated insulation voltage	Ui	V	690	690	690	690	690	1000		
Rated impulse withstand voltage	Uimp	kV	6	6	6	6	6	8		
AC rated operational current	Ie	AC21A	A	20	25	40	63	80	125	
Making capacity	Ieff	3x380-440V	A	160	190	300	370	440	850	
Breaking capacity		3x220-240V	A	160	180	250	330	380	680	
		3x380-440V	A	160	180	250	330	380	680	
Direct switching motors	AC3	3x660-690V	A	80	110	170	190	220	420	
		3x400V	A	12	16	30	37	37	72	
Main & safety switch	AC3	3x220-240V	kW	3	4	7,5	11	11	22	
		3x380-440V	kW	5,5	7,5	15	18,5	18,5	37	
		3x660-690V	kW	5,5	7,5	15	18,5	18,5	30	
		AC23	3x400V	A	16	20	32	45	45	85
		AC23A	3x220-240V	kW	4	5,5	9	15	15	30
Rated conditional short-circuit current	kAeff	3x380-440V	kW	7,5	10	16	22	22	45	
		3x660-690V	kW	5,5	7,5	15	18,5	18,5	37	
Max. fuse size	gL(gG)	A	25	35	50	63	80	125		
Rated short-time withstand current (1sec. current)	Icw	A	250	300	500	600	850	1500		
Mechanical life	x10 ³		200	200	200	100	100	100		
Connecting capacity										
Solid or stranded cable	mm ²		0,5-10		1-25 *(1)		4-50			
	AWG		20-8 (10)		16-4 (10)		10-0 (10)			
Flexible cable	mm ²		0,5-6		4-16 *(1)		10-35			
	AWG		20-10		16-6		8-2			
Size of terminal screw			M3,5		M5		M6			
Tightening torque	Nm		0,8-1,7		2-4		3,5-4,5			

According to UL & cUL FILE NO. E123623

			20	25	40	63	80	125
Rated voltage	V		600	600	600	600	600	600
Ampere-Rating "General use"	A		20	25	40	63	80	125
DOL-Rating 3-phase	HP	110-220V	1	1,5	2	3	5	15
		220-240V	3	5	5	10	10	30
		440-480V	7,5	10	10	20	20	60
		550-600V	10	10	15	25	25	60
DOL-Rating 1-phase	HP	110-120V	1	1	1	2	2	7,5
		200-208V	1	2	2	3	3	10
		220-240V	2	2	3	5	5	15
Fuse size (RK5)	A		40	50	70	90	110	125
5kA / 600V	A		40	50	50	70	70	125
Tightening torque	Nm		1,2-2,3	1,2-2,3	1,2-2,3	2,8-4	2,8-4	1,7-4,5
	lb.Inch		11-20	11-20	11-20	24-35	24-35	15-40

*(1) ZBK63...U trenzado 16 mm² / flexible 10 mm²

Accessories



Auxiliary contacts

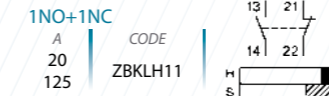

PE - Terminal



N - Terminal

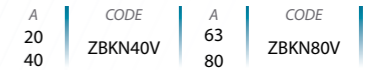

N - Terminal immovable



Auxiliary contacts technical information

Rated insulation voltage	Ui	V	690	
Rated thermal current	Ith - Ithe	A	10	
Switching capacity	AC15	220-240V	A	2,5
	AC15	380-440V	A	1,5
Rated conditional short-circuit current		kAeff	3	
Max. short circuit protection	gL(gG)	A	10	

Connecting capacity

Solid or stranded cable	mm ²	0,75-2,5
	AWG	14-12
Flexible cable (+ multicore cable end)	mm ²	0,75-2,5 (1,5)
	AWG	18-14

Dimensions (mm)

Panel drilling for panel handle

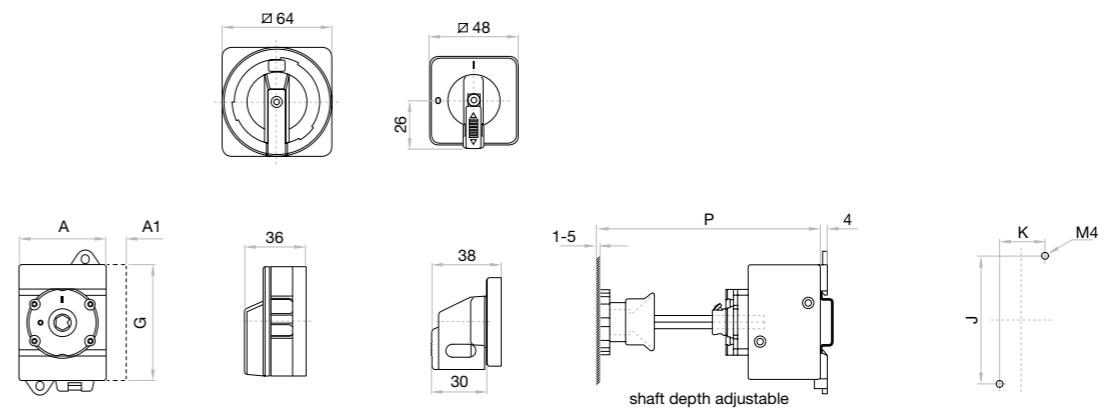
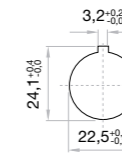

A	3P		4P		P	
	A	G	J	K	min	max
20 - 40 A	48	64	70	25	91	190
63 - 80 A	48	64	70	25	91	190
125 A	78	85	90	38	95	190

Auxiliary contacts A1

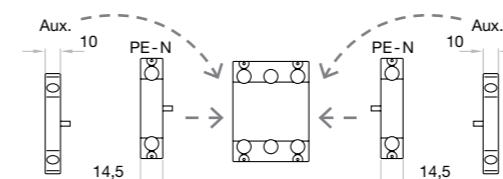

- Other options also available on request:
- Products with customized shaft dimensions
- Terminal shrouds

ZBK

Switch base mounting $\varnothing 22$ door clutch padlockable handle IP66

6P - 8P

Size 0
A 25|40|80



	CODE - 25A	CODE - 40A	CODE - 80A
6P	ZBK25VZVHN4A6	ZBK40VZVHN4A6	ZBK80VZVHN4A6
8P	ZBK25VZVHN4A8	ZBK40VZVHN4A8	ZBK80VZVHN4A8
6P	ZBK25VZVH4A6	ZBK40VZVH4A6	ZBK80VZVH4A6
8P	ZBK25VZVH4A8	ZBK40VZVH4A8	ZBK80VZVH4A8

Technical information



According to VDE 0660, IEC/EN 60947-3, IEC/EN 60947-5-1

			25	40	80
Rated thermal current	Ith	A	25	40	80
Rated thermal current enclosed	Ithe	A	25	40	80
Rated insulation voltage	Ui	V	690	690	690
Rated impulse withstand voltage	Uimp	kV	6	6	6
AC rated operational current	Ie	AC21A A	25	40	80
Making capacity	Ieff	3x380-440V A	190	300	440
Breaking capacity		3x220-240V A	180	250	380
		3x380-440V A	180	250	380
		3x660-690V A	110	170	220
Direct switching motors	AC3	3x400V A	16	30	37
		3x220-240V kW	4	7,5	11
	AC3	3x380-440V kW	7,5	15	18,5
		3x660-690V kW	7,5	15	18,5
Main & safety switch	AC23	3x400V A	20	32	45
	AC23A	3x220-240V kW	5,5	9	15
	AC23B	3x380-440V kW	10	16	22
		3x660-690V kW	7,5	15	18,5
Rated conditional short-circuit current	kAeff	10	10	10	
Max. fuse size	gL(gG)	A	35	50	80
Rated short-time withstand current (1sec. current)	Icw	A	300	500	850
Mechanical life	x10 ³		200	200	100
Connecting capacity					
Solid or stranded cable	mm ²		0,5-10		1-25
	AWG		20-8 (10)		16-4 (10)
Flexible cable	mm ²		0,5-6		4-16
	AWG		20-10		16-6
Size of terminal screw			M3,5		M5
Tightening torque	Nm		0,8-1,7		2-4

According to UL & cUL FILE NO. E123623

			25	40	80
Rated voltage	V		600	600	600
Ampere-Rating "General use"	A		25	40	80
DOL-Rating 3-phase	110-220V	HP	1,5	2	5
	220-240V	HP	5	5	10
	440-480V	HP	10	10	20
	550-600V	HP	10	15	25
DOL-Rating 1-phase	110-120V	HP	1	1	2
	200-208V	HP	2	2	3
	220-240V	HP	2	3	5
Fuse size (RK5)	Manual Motor Controller	A	50	70	110
5kA / 600V	Motor Disconnect	A	50	50	70
Tightening torque	Nm		1,2-2,3	1,2-2,3	2,8-4
	lb.Inch		11-20	11-20	24-35

Accessories



» Auxiliary contacts



» PE - Terminal



» N - Terminal

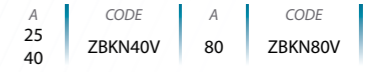

» N - Terminal immovable



Auxiliary contacts technical information

Rated insulation voltage	Ui	V	690
Rated thermal current	Ith - Ithe	A	10
Switching capacity	AC15	220-240V A	2,5
	AC15	380-440V A	1,5
Rated conditional short-circuit current	kAeff		3
Max. short circuit protection	gL(gG)	A	10

Connecting capacity

Solid or stranded cable	mm ²	0,75-2,5
	AWG	14-12
Flexible cable (+ multicore cable end)	mm ²	0,75-2,5 (1,5)
	AWG	18-14

Dimensions (mm)

Panel drilling for panel handle

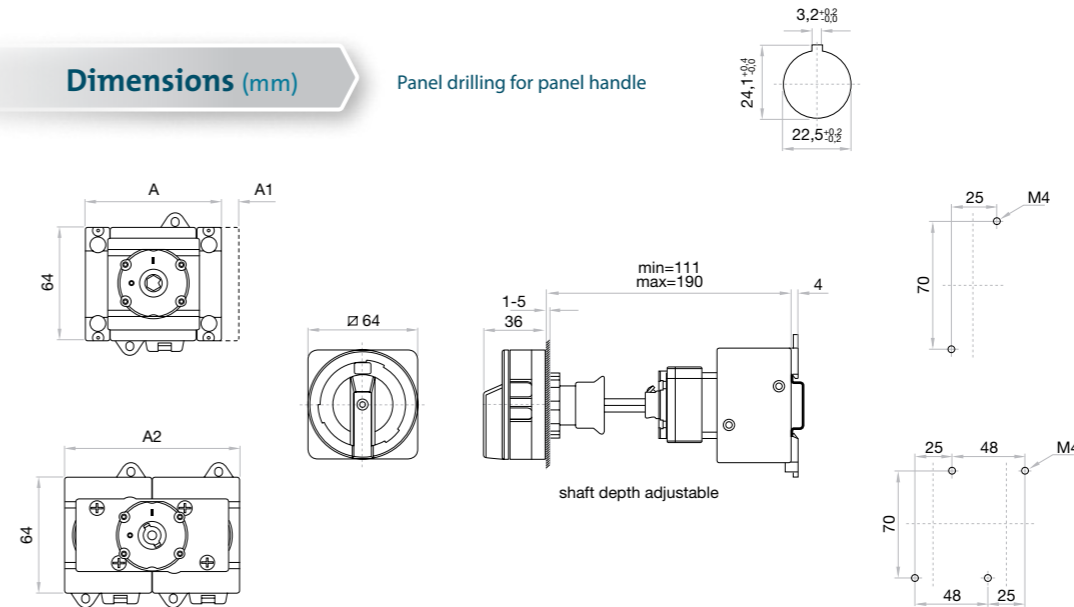

	6P	6P	8P
	A	A2	A2
25 - 40 A	77	-	97
80 A	-	97	126

Auxiliary contacts A1

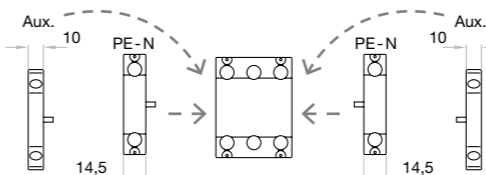

- » Other options also available on request:
 - Products with customized shaft dimensions
 - Terminal shrouds

ZBK Switch & changeover DIN rail mounting modular padlockable handle IP40

Size 0

A 20|25|40|63|80|125



Accessories

>> Auxiliary contacts

1NO+1NC
A 20 125
CODE ZBKLH11

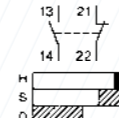

1NO+1NC overlapping
A 20 125
CODE ZBKLH11X

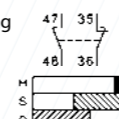

>> PE - Terminal



A 20 80
CODE ZBKPE80V
A 125
CODE ZBKLTXX-E/V

>> N - Terminal immovable



A 20 80
CODE ZBKPEN80V
A 125
CODE ZBKLTXX-N/V

Auxiliary contacts technical information

Rated insulation voltage	Ui	V	690
Rated thermal current	Ith - Ithe	A	10
Switching capacity	AC15	220-240V	A 2,5
	AC15	380-440V	A 1,5
Rated conditional short-circuit current		kAeff	3
Max. short circuit protection	gL(GG)	A	10

Connecting capacity

Solid or stranded cable	mm ²	0,75-2,5
	AWG	14-12
Flexible cable (+ multicore cable end)	mm ²	0,75-2,5 (1,5)
	AWG	18-14

Technical information



According to VDE 0660, IEC/EN 60947-3, IEC/EN 60947-5-1

		20	25	40	63	80	125
Rated thermal current	Ith	A	20	25	40	63	80
Rated thermal current enclosed	Ithe	A	20	25	40	63	80
Rated insulation voltage	Ui	V	690	690	690	690	1000
Rated impulse withstand voltage	Uimp	kV	6	6	6	6	8
AC rated operational current	Ie	A	20	25	40	63	80
AC rated operational current	Ie	A	20	25	40	63	80
Rated conditional short-circuit current	kAeff	10	10	10	10	10	10
Max. fuse size	gL(GG)	A	25	35	50	63	80
Rated short-time withstand current (1 sec. current)	Icw	A	250	300	500	600	850
Mechanical life	x10 ³	200	200	200	100	100	100
Connecting capacity							
Solid or stranded cable	mm ²	0,5-10			1-25 *(1)		4-50
	AWG	20-8 (10)			16-4 (10)		10-0 (10)
Flexible cable	mm ²	0,5-6			4-16 *(1)		10-35
	AWG	20-10			16-6		8-2
Size of terminal screw		M3,5			M5		M6
Tightening torque	Nm	0,8-1,7			2-4		3,5-4,5

According to UL & cUL FILE NO. E123623

		20	25	40	63	80	125
Rated voltage	V	600	600	600	600	600	600
Ampere-Rating "General use"	A	20	25	40	63	80	125
DOL-Rating 3-phase	110-220V	HP	1	1,5	2	3	5
	220-240V	HP	3	5	5	10	10
	440-480V	HP	7,5	10	10	20	20
	550-600V	HP	10	10	15	25	25
	220-240V	HP	2	2	3	5	5
DOL-Rating 1-phase	110-120V	HP	1	1	1	2	2
	200-208V	HP	1	2	2	3	3
	220-240V	HP	2	2	3	5	5
Fuse size (RK5)	A	40	50	70	90	110	125
5kA / 600V	A	40	50	50	70	70	125
Tightening torque	Nm	1,2-2,3	1,2-2,3	1,2-2,3	2,8-4	2,8-4	1,7-4,5
	lb.Inch	11-20	11-20	11-20	24-35	24-35	15-40

*(1) ZBK63___U trenzado 16 mm² / flexible 10 mm²

Dimensions (mm)

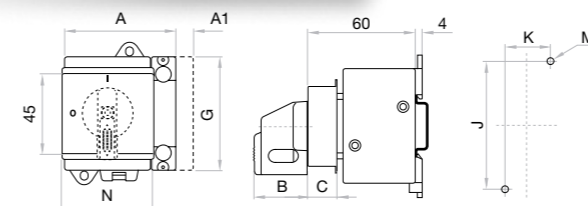

3P-4P 20-125A

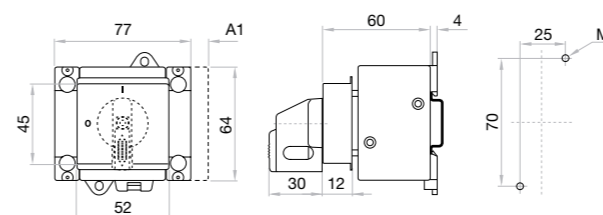

6P 25-40A

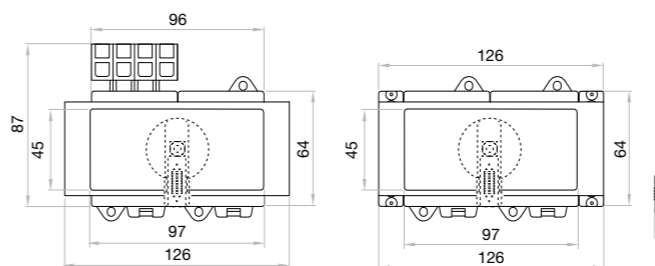

20-40A

63A

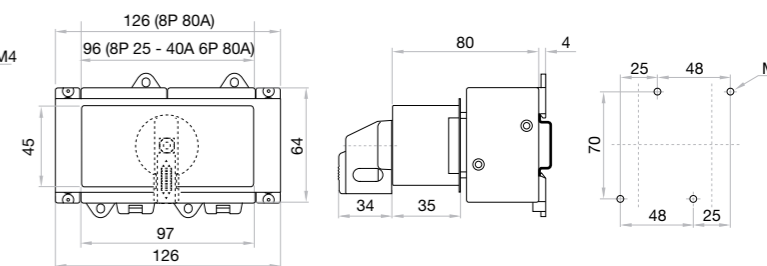

8P 25-40A
6P-8P 80A

Auxiliary contacts A1

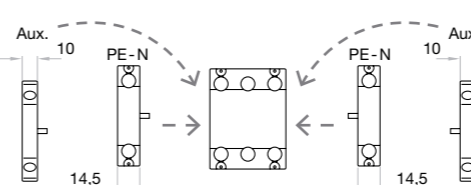

Switch

	3P	4P	A	B	C	G	J	K	N
20-40 A	48	48	30	12	64	70	25	52	
63-80 A	48	62,5	30	12	64	70	25	52	
125 A	78	78	35	10	85	90	38	78	

Changeover

>> Other options also available on request:
- Terminal shrouds
- Changeoveres de 3P

ZBK

Switch plastic enclosure padlockable handle 3P - 3P+N - 6P - 8P

Size 0

A 20|25|40|63|80|125



3P-3P+N

6P-8P

	CODE-20A	CODE-25A	CODE-40A	CODE-63A	CODE-80A	CODE-125A
3P	ZBK20PFHN4A3	ZBK25PFHN4A3	ZBK40PFHN4A3	ZBK63PFHN4A3	ZBK80PFHN4A3	ZBK125PFHN4A3
3P + N	ZBK20PFHN4A4	ZBK25PFHN4A4	ZBK40PFHN4A4	ZBK63PFHN4A4	ZBK80PFHN4A4	ZBK125PFHN4A4
6P	-	ZBK25PFHN4A6	ZBK40PFHN4A6	-	ZBK80PFHN4A6	-
8P	-	ZBK25PFHN4A8	ZBK40PFHN4A8	-	ZBK80PFHN4A8	-

Technical information

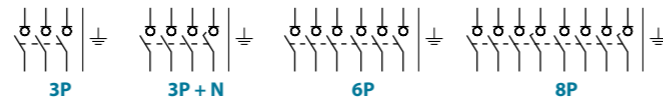

According to VDE 0660, IEC/EN 60947-3, IEC/EN 60947-5-1

			20	25	40	63	80	125		
Rated thermal current	I _{th}	A	20	25	40	63	80	125		
Rated thermal current enclosed	I _{the}	A	20	25	40	63	80	110		
Rated insulation voltage	U _i	V	690	690	690	690	690	1000		
Rated impulse withstand voltage	U _{imp}	kV	6	6	6	6	6	8		
AC rated operational current	I _e	AC21A	20	25	40	63	80	125		
Making capacity	I _{eff}	3x380-440V	160	190	300	370	440	850		
Breaking capacity		3x220-240V	160	180	250	330	380	680		
		3x380-440V	160	180	250	330	380	680		
Direct switching motors	AC3	3x660-690V	80	110	170	190	220	420		
		3x400V	12	16	30	37	37	72		
		3x220-240V	kW	3	4	7,5	11	11	22	
		3x380-440V	kW	5,5	7,5	15	18,5	18,5	37	
Main & safety switch	AC23B	3x660-690V	kW	5,5	7,5	15	18,5	18,5	30	
		3x400V	A	16	20	32	45	45	85	
		AC23A	3x220-240V	kW	4	5,5	9	15	15	30
		AC23B	3x380-440V	kW	7,5	10	16	22	22	45
Rated conditional short-circuit current	kA _{eff}	3x660-690V	kW	5,5	7,5	15	18,5	18,5	37	
		3x380-440V	kW	5,5	7,5	15	18,5	18,5	37	
Max. fuse size	gL(gG)	A	25	35	50	63	80	125		
Rated short-time withstand current (1sec. current)	I _{cw}	A	250	300	500	600	850	1500		
Mechanical life		x10 ³	200	200	200	100	100	100		
Connecting capacity										
Solid or stranded cable	mm ²		0,5-10		1-25 *(1)		4-50			
		AWG	20-8 (10)		16-4 (10)		10-0 (10)			
Flexible cable	mm ²		0,5-6		4-16 *(1)		10-35			
		AWG	20-10		16-6		8-2			
Size of terminal screw			M3,5		M5		M6			
Tightening torque	Nm		0,8-1,7		2-4		3,5-4,5			

According to UL & cUL FILE NO. E123623

			20	25	40	63	80	125
Rated voltage	V		600	600	600	600	600	600
Ampere-Rating "General use"	A		20	25	40	63	80	125
DOL-Rating 3-phase	HP	110-220V	1	1,5	2	3	5	15
		220-240V	3	5	5	10	10	30
		440-480V	7,5	10	10	20	20	60
		550-600V	10	10	15	25	25	60
DOL-Rating 1-phase	HP	110-120V	1	1	1	2	2	7,5
		200-208V	1	2	2	3	3	10
		220-240V	2	2	3	5	5	15
Fuse size (RK5)	A		40	50	70	90	110	125
5kA / 600V	A		40	50	50	70	70	125
Tightening torque	Nm		1,2-2,3	1,2-2,3	1,2-2,3	2,8-4	2,8-4	1,7-4,5
		lb.Inch	11-20	11-20	11-20	24-35	24-35	15-40

*(1) ZBK63__U trenzado 16 mm² / flexible 10 mm²

Accessories



» Auxiliary contacts



» Auxiliary contacts



Auxiliary contacts technical information

Rated insulation voltage	U _i	V	690	
Rated thermal current	I _{th} - I _{the}	A	10	
Switching capacity	AC15	220-240V	A	2,5
	AC15	380-440V	A	1,5
Rated conditional short-circuit current		kA _{eff}	3	
Max. short circuit protection	gL(gG)	A	10	

Connecting capacity		
Solid or stranded cable	mm ²	0,75-2,5
	AWG	14-12
Flexible cable (+ multicore cable end)	mm ²	0,75-2,5 (1,5)
	AWG	18-14

Dimensions (mm)

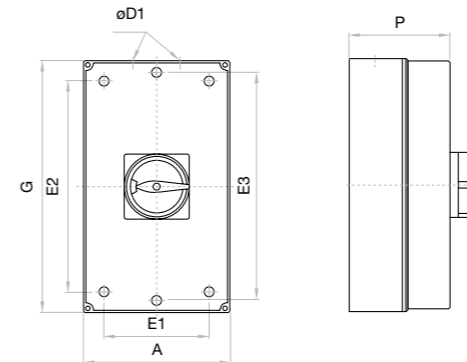

		A	D1	E1	E2	E3	G	P
20-40 A	3/4P	98	2x25,5/20,5	-	-	120	130	77
63-125 A	3/4P	120	40,5/32,5+16,5	90	188	-	200	86
25-40 A	6P	120	40,5/32,5+16,5	90	188	-	200	86
25-40 A	8P	160	40,5/32,5	130	228	-	240	120
80 A	6/8P	160	40,5/32,5	130	228	-	240	120

Auxiliary contacts

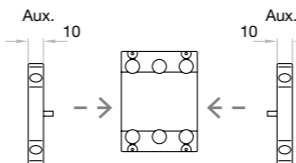

- » Other options also available on request:
- Changeovers
 - Black/grey handle

AC Switch - disconnectors

Switch - disconnectors with high operating load capacity and a high level disconnection insulation; high reliability and safety in abnormal situations, available in different construction models, with a wide range of currents and various accessories.

series
S5|S5M

series
S6

series
CIS

According to:
IEC/EN 60947-3
IEC/EN 61439-1
RoHS



Testing and approvals:



Functional and ergonomic handle

- > Good grip and excellent torque/resistance
- > Padlockable handle in **0 OFF** position (up to three locks Ø 5-8 mm)
- > Door interlock in **ON I** position
- > Door interlock in **0 OFF** position, with lock on
- > Release feature in **ON I** position (with the use of a tool for maintenance operations). The handle internal lock is automatically restored
- > Self-centering shaft for door handle



The switch - disconnectors in its different series, are manufactured with high safety self-extinguishing materials, providing an excellent level of electrical insulation, low smoke emission and high resistance to electromechanical stress.

They comply with environmental requirements and undergo strict quality controls for a reliable product that meets the most demanding requirements.

They consist of a sandwich-type body containing self-cleaning blade type contacts, with pre-arc zones to ensure long term, fault-free energy transmission and coated with silver alloy for long electromechanical life. The jump mechanism provides quick and independent switching due to the accumulation of elastic potential energy, which is transmitted at high speed to the contacts for arc extinction.

Neutral pole advanced during closing and withdrawn while opening

A safety system preventing accidental overvoltage during switching in receptors powered between phase and neutral.

Due to the design in our 3P+N switch - disconnectors and changeover switches, the neutral contact closes before the main phases and opens later, thus ensuring this operation mode.

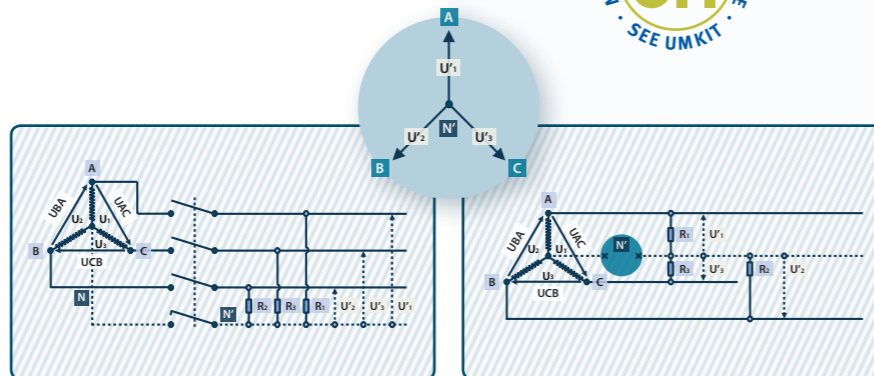

Range coding:

The S5|S5M|S6 series, are identified by a code that describes their most important characteristics as described below

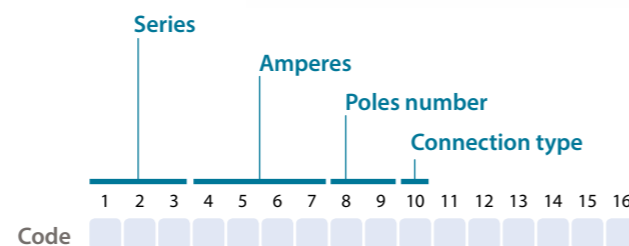

series
S5

Wide range of currents.
Base mounting with screws.
Switching under load up to 1000Vac (inductive and capacitive).
Cut-off current up to 8 times the operational current.
Able to establish and withstand short-circuit currents up to 100kA.
Panel or direct handles.



series
S5M

Back to back arrangement to increase the number of available contacts between 6 or 8.
Base mounting with screws.
Panel or direct handles.



series
S6

Switch - disconnectors with housings for 2P - 3P or 3P+N.
Base mounting with screws.
Panel or direct handles.
Wide range of devices and accessories.

series
CIS25D



series
CIS25D

S5000 polyester enclosed switch.
External padlockable handle with locking cover in ON I position.
Removing cover blocked by padlock when handle is in 0 OFF position.

series
CIS25C



series
CIS25C

S5000 metal enclosed switch.
External padlockable handle with locking door in ON I position.
Door opening blocked by padlock when handle is in 0 OFF position.

series
CIS25A



series
CIS25A

S5000 polyester enclosed switch and fuse holders.
External padlockable handle with locking cover in ON I position.
Removing cover blocked by padlock when handle is in 0 OFF position.

series
CIS25F



series
CIS25F

S5000 metal enclosed switch and fuse holders.
External padlockable handle with locking door in ON I position.
Door opening blocked by padlock when handle is in 0 OFF position.

S5000 AC Switch - disconnecter base mounting 2P - 3P - 3P+N

Size 00
A 40|63|80



	CODE-40A	CODE-63A	CODE-80A
2P	S5-00402PB0	S5-00632PB0	S5-00802PB0
3P	S5-00403PB0	S5-00633PB0	S5-00803PB0
3P + N	S5-00403NB0	S5-00633NB0	S5-00803NB0

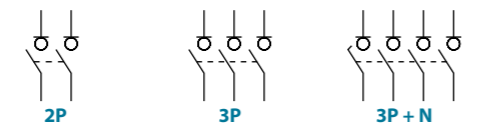

Technical information

According to IEC/EN 60947-3



		40			63			80					
Rated thermal current in ambient at	Ith	40 °C	A	50	63	80	40 °C	A	50	63	80		
		50 °C	A	50	63	80	50 °C	A	50	63	80		
		60 °C	A	40	63	64	60 °C	A	40	63	64		
Rated insulation voltage	Ui	V			800	800	800	V			3500	3500	3500
Rated dielectric strength	50 Hz., 1 min.	V			3500	3500	3500	V			3500	3500	3500
Rated impulse withstand voltage	Uimp	kV			8	8	8	kV			8	8	8
AC rated operational current ^{*(1)} (Rated operational frequency 50/60 Hz)	Ie	Ue 400V	AC21A	A	50	63	80	Ue 400V	AC22A	A	50	63	80
		Ue 400V	AC23A	A	50	63	80	Ue 400V	AC23A	A	50	63	80
		Ue 500V	AC21A	A	50	63	80	Ue 500V	AC22A	A	50	63	80
		Ue 500V	AC22A	A	50	63	80	Ue 500V	AC23A	A	50	63	80
		Ue 500V	AC23A	A	40	50	50						
AC rated operational power ^{*(2)}	Pe	3x400V	AC23A	kW	27,7	34,9	34,9						
Rated capacitor power	400V, sen φ = 0,65	kVA	22,5	28,3	28,3								
Rated breaking capacity	400V	AC23A	A	400	504	504							
Rated making capacity	400V	AC23A	A	500	630	630							

		40			63			80		
Short - circuit behaviour										
Rated short-circuit making capacity ^{*(3)}	Icm	kA (peak)	5	5	5	5	5	5	5	5
Rated short-time withstand current (1sec.)	Icw	kA rms	3	3	3	3	3	3	3	3
Conditional short - circuit current (rms value) ^{*(4)}		kA rms	100	100	100	100	100	100	100	100
Maximum cut - off current (peak value)		kA (peak)	10	10	10	10	10	10	10	10
Maximum power dissipation (I ² t)		A ² s (x10 ³)	54,7	54,7	54,7	54,7	54,7	54,7	54,7	54,7
Mechanical features										
Minimum number of mechanical operations ^{*(5)}		Cycles	30000	30000	30000	30000	30000	30000	30000	30000
Maximum weight		Kg	0,4	0,4	0,4	0,4	0,4	0,4	0,4	0,4

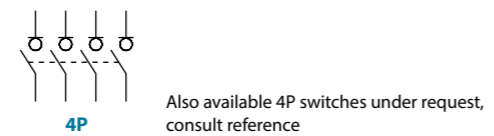

Accessories

- Direct handle**
CODE DS-SI01
- Panel handle** included shaft ^{*(e1)}
IP65
CODE DS-SA01
- Panel handle** without shaft
IP65
CODE DS-SA03
- Emergency panel handle** included shaft ^{*(e1)}
IP65
CODE DS-SR01

Auxiliary contacts
1NO+1NC CODE D5LAU01
2NO+2NC CODE D5LAU02
Ie = 16 A (resistive loads)
4 A (inductive loads) at 250 Vac.

Safety key lock device
Simple CODE DS-CAB1
Double CODE DS-CEB1

For external handle, lock the handle by means of a key in position "OFF" (under request, in "ON"), the key can only be removed with the handle locked

Panel drilling for handle and keylock device
Simple Double

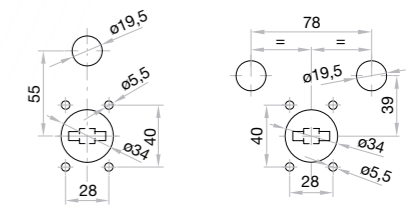

Shafts

Standard shaft included ^{*(e1)}
L (mm) | P (mm) |
177 | 85... 195,5

Shaft extensions
Type 1
L (mm) | P (mm) | CODE
250 | 85... 278 | DS-EP04

Type 2
L (mm) | P (mm) | CODE
387 | 85... 415 | DS-EP05

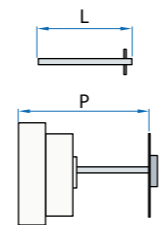

Dimensions (mm)

Panel drilling for panel handle

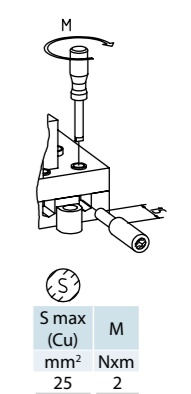
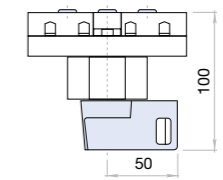
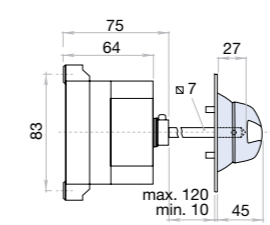
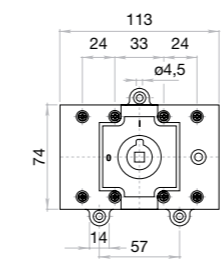

S5000 AC Switch - disconnecter base mounting 2P - 3P - 3P+N

Size 0
A 125|160|200|250

	CODE-125A	CODE-160A	CODE-125A	CODE-160A	CODE-200A	CODE-250A
2P	S5-01252PB0	S5-01602PB0	S5-01252PS0	S5-01602PS0	S5-02002PS0	S5-02502PD0
3P	S5-01253PB0	S5-01603PB0	S5-01253PS0	S5-01603PS0	S5-02003PS0	S5-02503PD0
3P+N	S5-01253NB0	S5-01603NB0	S5-01253NS0	S5-01603NS0	S5-02003NS0	S5-02503ND0

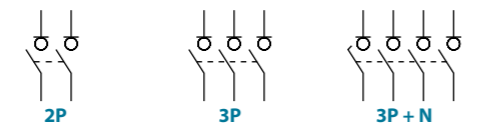

Technical information

According to IEC/EN 60947-3



		125 160 200 250				
Rated thermal current Ith in ambient at	40 °C	A	125	160	200	250
	50 °C	A	125	160	200	250
	60 °C	A	125	160	200	200
Rated insulation voltage	Ui	V	1000	1000	1000	1000
Rated dielectric strength	50 Hz, 1 min.	V	4000	4000	4000	5000
Rated impulse withstand voltage	Uimp	kV	8	8	8	8
AC rated operational current ⁽¹⁾ (Rated operational frequency 50/60 Hz)	Ue 400V AC21A	A	125	160	200	250
	Ue 400V AC22A	A	125	160	200	250 ⁽⁶⁾
	Ue 400V AC23A	A	125	160	160	160
	Ue 500V AC21A	A	125	160	200	200
	Ue 500V AC22A	A	125	160	200	200
AC rated operational power ⁽²⁾	3x400V AC23A	kW	69,2	88,6	88,6	88,6
	400V, sen φ = 0,65	kVA	56,2	72	72	72
Rated breaking capacity	400V AC23A	A	1000	1280	1280	1280
Rated making capacity	400V AC23A	A	1250	1600	1600	1600

		125 160 200 250			
Short - circuit behaviour					
Rated short-circuit making capacity ⁽³⁾	Icm kA (peak)	13	13	13	13
Rated short-time withstand current (1sec.)	Icw kA rms	7	7	7	7
Conditional short - circuit current (rms value) ⁽⁴⁾	kA rms	100	100	100	100
Maximum cut - off current (peak value)	kA (peak)	17	20	20	20
Maximum power dissipation (I ² t)	A ² s (x10 ³)	55	198	198	198
Mechanical features					
Minimum number of mechanical operations ⁽⁵⁾	Cycles	30000	30000	30000	30000
Maximum weight 3P	Kg	0,85	0,85	0,9	0,9
Maximum weight 3P+N	Kg	1	1	1	1

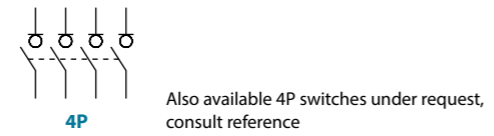

⁽¹⁾ Other voltages and / or utilization categories. Please consult
⁽²⁾ Indicative values: current values vary from one motor manufacturer to another
⁽³⁾ Without limiting protective device (short-circuit maintained 50... 100 ms.)
⁽⁴⁾ With a protective device limiting the cut - off current and the joule integral to the indicated values
⁽⁵⁾ Please consult us for more operations
⁽⁶⁾ Rated operational current AC22B

Accessories

- Direct handle**
CODE DS-SI01
- Panel handle** included shaft ^(e1)
IP65
CODE DS-SA01
- Panel handle** without shaft
IP65
CODE DS-SA03
- Emergency panel handle** included shaft ^(e1)
IP65
CODE DS-SR01
- Terminal protection**
CODE DS-CU01
(1 unit for input or output)
- DIN rail mounting**
CODE DS-DN01
(1 kit for 125-160A switches)
- Auxiliary contacts**
1NO+1NC CODE D5LAU01
2NO+2NC CODE D5LAU02
Ie = 16 A (resistive loads)
4 A (inductive loads) at 250 Vac.
- Safety key lock device**
Simple CODE DS-CAB1
Double CODE DS-CEB1
For external handle, lock the handle by means of a key in position "OFF" (under request, "ON"), the key can only be removed with the handle locked

Shafts

Standard shaft included ^(e1)

L (mm)	P (mm)	CODE
177	87...197,5	

Shaft extensions

Type 1		
L (mm)	P (mm)	CODE
250	87...278	DS-EP04
Type 2		
L (mm)	P (mm)	CODE
387	87...415	DS-EP05

Dimensions (mm)

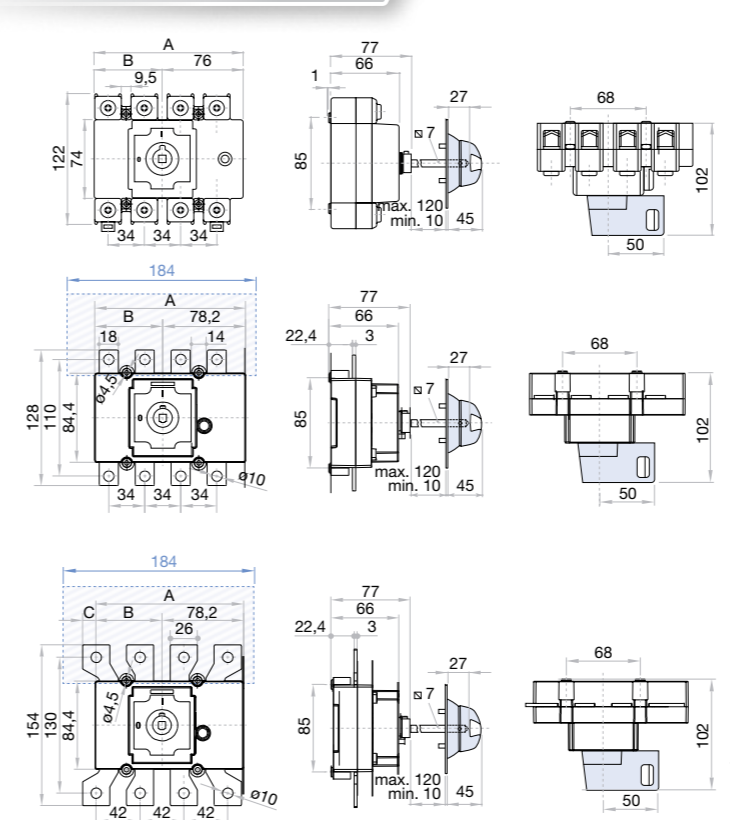

Panel drilling for panel handle

A	B			S max (Cu) mm ²	M
	2P	3P	4P		
125 A	129	129	140	95	4
160 A	129	140	53	95	4

A	B			S max (Cu) mm ²	H max (Cu) mm	L max (Cu) mm	M
	2P	3P	4P				
125 A	131	131	142	95	5	25	M8
160 A	131	142	53	95	5	25	M8

A	B			C	S max (Cu) mm ²	Z max	H max (Cu) mm	L max (Cu) mm	M
	2P	3P	4P						
200 A	131	131	142	53	53	64	11,8	120	30
250 A	131	131	142	53	53	64	11,8	120	30

S5000 AC Switch - disconnecter base mounting 2P - 3P - 3P+N

Size 1
A 250|315|400

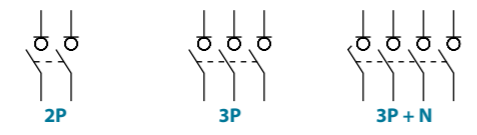
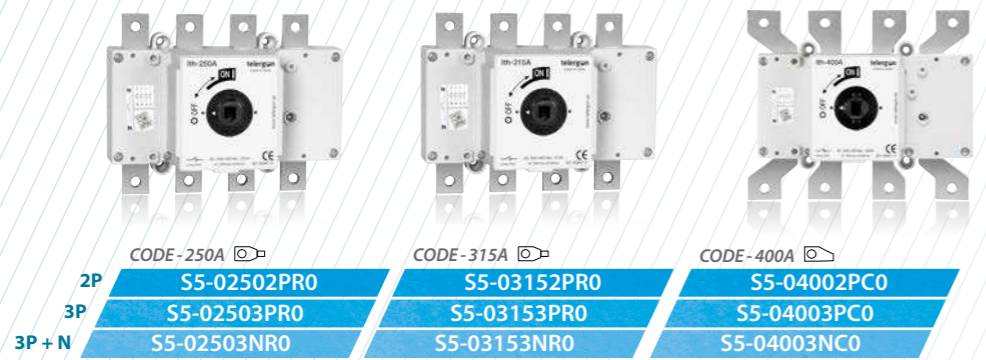

Technical information

According to IEC/EN 60947-3



		250			315			400		
Rated thermal current in ambient at	Ith	40 °C	A	250	315	400				
		50 °C	A	250	315	400				
		60 °C	A	250	315	320				
Rated insulation voltage	Ui	V			1000	1000	1000			
Rated dielectric strength	50 Hz., 1 min.	V			5000	5000	5000			
Rated impulse withstand voltage	Uimp	kV			8	8	8			
AC rated operational current ^{*(1)} (Rated operational frequency 50/60 Hz)	Ie	Ue 400V AC21A	A	250	315	400				
		Ue 400V AC22A	A	250	315	400				
		Ue 400V AC23A	A	250	315	400				
		Ue 500V AC21A	A	250	315	400				
		Ue 500V AC22A	A	250	315	400				
		Ue 500V AC23A	A	200	250	315				
AC rated operational power ^{*(2)}	Pe	3x400V AC23A	kW	138,5	174,5	221,7				
Rated capacitor power	400V, sen φ = 0,65	kVAr	112,5	141,8	180,1					
Rated breaking capacity	400V AC23A	A	2000	2520	3200					
Rated making capacity	400V AC23A	A	2500	3150	4000					

		250			315			400		
Short - circuit behaviour										
Rated short-circuit making capacity ^{*(3)}	Icm	kA (peak)	20	20	20					
Rated short-time withstand current (1sec.)	Icw	kA rms	12	12	12					
Conditional short - circuit current (rms value) ^{*(4)}	Ika	kA rms	100	100	100					
Maximum cut - off current (peak value)		kA (peak)	33	33	33					
Maximum power dissipation (I ² t)		A ² s (x10 ³)	1000	1000	1000					
Mechanical features										
Minimum number of mechanical operations ^{*(5)}	Cycles	20000	20000	20000						
Maximum weight 3P		Kg	1,7	1,7	1,9					
Maximum weight 3P+N		Kg	1,9	1,9	2,1					

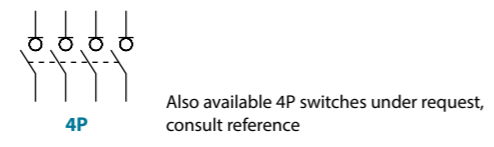

^{*(1)} Other voltages and / or utilization categories. Please consult
^{*(2)} Indicative values: current values vary from one motor manufacturer to another
^{*(3)} Without limiting protective device (short-circuit maintained 50... 100 ms.)
^{*(4)} With a protective device limiting the cut - off current and the joule integral to the indicated values
^{*(5)} Please consult us for more operations



Accessories

- Direct handle**
CODE DS-SI11
- Panel handle** included shaft ^{*(e1)}
IP65|UL50E/NEMA 250
Types: 1, 3R, 4, 4X y 12
CODE DS-SA11
- Panel handle** without shaft
IP65|UL50E/NEMA 250
Types: 1, 3R, 4, 4X y 12
CODE DS-SA14
- Emergency panel handle** included shaft ^{*(e1)}
IP65|UL50E/NEMA 250
Types: 1, 3R, 4, 4X y 12
CODE DS-SR11
- Terminal protection**
CODE DS-CU12
(1 unit for input or output)
- Terminal shrouds**
CODE DS-CU11
(1 kit for input or output)
- Auxiliary contacts**
1NO+1NC CODE D5LAU01
2NO+2NC CODE D5LAU02
Ie = 16 A (resistive loads)
4 A (inductive loads) at 250 Vac.
- Safety key lock device**
Simple CODE DS-CA11
Double CODE DS-CE11
For external handle, lock the handle by means of a key in position "OFF" (under request, in "ON"), the key can only be removed with the handle locked

Shafts

Standard shaft		included ^{*(e1)}	
L (mm)	P (mm)	227	103... 256
Shaft extensions		CODE	
Type 1		DS-EP14	
L (mm)	P (mm)	375	103... 415
Type 2		DS-EP15	
L (mm)	P (mm)	536	103... 576

Dimensions (mm)

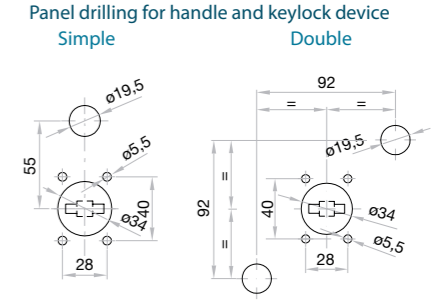
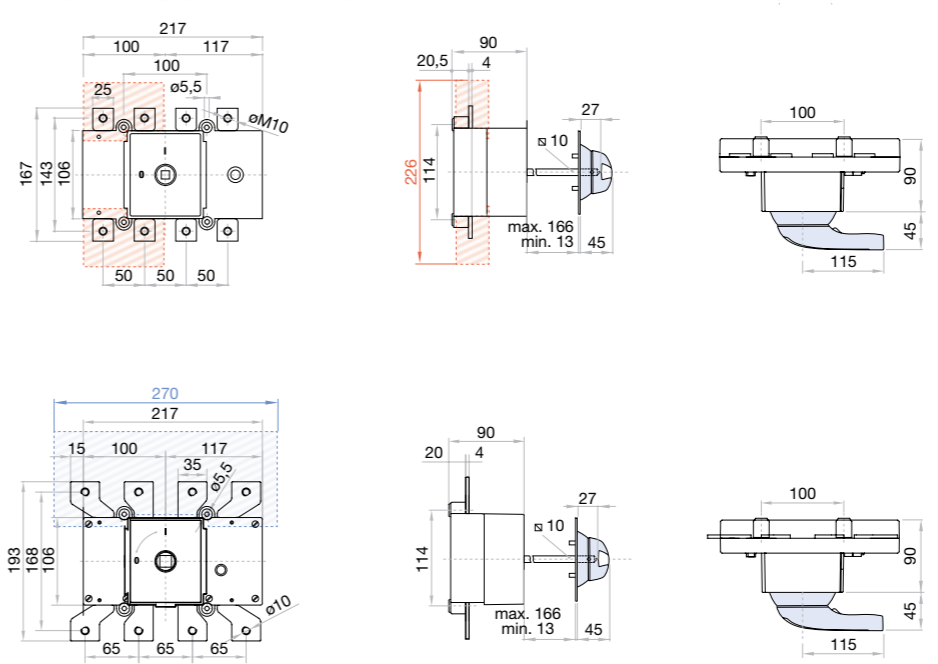

Panel drilling for panel handle

S max (Cu) mm ²	H max (Cu) mm	L max (Cu) mm	M
250 A	185	7	25 M10
315 A	185	7	25 M10

S max (Cu) mm ²	Z max	H max (Cu) mm	L max (Cu) mm	M
400 A	240	44	7	40 M10

S5000 AC Switch - disconnecter base mounting 3P - 3P+N

Size 2
A 500|630|800

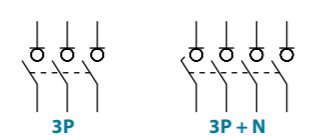

Technical information

According to IEC/EN 60947-3



		500 630 800		
Rated thermal current in ambient at	Ith	40 °C	A	500 630 800
		50 °C	A	500 630 720
		60 °C	A	500 630 640
Rated insulation voltage	Ui	V		1000 1000 1000
Rated dielectric strength	50 Hz, 1 min.	V		8000 8000 8000
Rated impulse withstand voltage	Uimp	kV		12 12 12
AC rated operational current ^{*(1)} (Rated operational frequency 50/60 Hz)	Ie	Ue 400V AC21A	A	500 630 800
		Ue 400V AC22A	A	500 630 800
	Ue 400V AC23A	A	500 630 800	
	Ue 500V AC21A	A	500 630 800	
	Ue 500V AC22A	A	500 630 800	
	Ue 500V AC23A	A	400 500 500	
AC rated operational power ^{*(2)}	Pe	3x400V AC23A	kW	277,1 349,1 443,4
Rated capacitor power	400V, sen φ = 0,65	kVA		225,1 283,7 360,2
Rated breaking capacity	400V AC23A	A		4000 5000 6400
Rated making capacity	400V AC23A	A		5000 6300 8000

		500 630 800			
Short - circuit behaviour					
Rated short-circuit making capacity ^{*(3)}	Icm	kA (peak)	26	26	26
Rated short-time withstand current (1sec.)	Icw	kA rms	16	16	16
Conditional short - circuit current (rms value) ^{*(4)}		kA rms	100	100	100
Maximum cut - off current (peak value)		kA (peak)	39	39	39
Maximum power dissipation (I ² t)		A ² s (x10 ³)	1600	1600	1600
Mechanical features					
Minimum number of mechanical operations ^{*(5)}	Cycles		10000	10000	10000
Maximum weight 3P		Kg	4,2	4,2	4,2
Maximum weight 3P+N		Kg	4,5	4,5	4,5

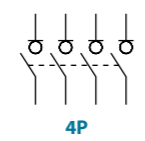

Also available 4P switches under request, consult reference

Accessories

- Direct handle**
CODE DS-LI21
- Panel handle** included shaft ^{*(e1)}
IP65|UL50E/NEMA 250
Types: 1, 3R, 4, 4X y 12
CODE DS-LA21
- Panel handle** without shaft
IP65|UL50E/NEMA 250
Types: 1, 3R, 4, 4X y 12
CODE DS-LA24
- Emergency panel handle** included shaft ^{*(e1)}
IP65|UL50E/NEMA 250
Types: 1, 3R, 4, 4X y 12
CODE DS-LR21
- Terminal protection**
CODE DS-CU22
(1 unit for input or output)
- Terminal shrouds**
CODE DS-CU21
(1 kit for input or output)
- Auxiliary contacts**
1NO+1NC CODE D5LAU01
2NO+2NC CODE D5LAU02
Ie = 16 A (resistive loads)
4 A (inductive loads) at 250 Vac.
- Safety key lock device**
Simple CODE DS-CB21
Double CODE DS-CF21

Panel drilling for handle and keylock device
Simple Double

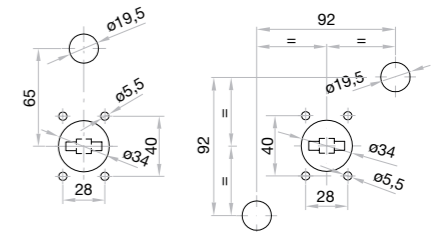

Shafts

Standard shaft included ^{*(e1)}
L (mm) | P (mm) |
195 | 134... 240 |

Shaft extensions
Type 1
L (mm) | P (mm) | CODE
345 | 134... 400 | DS-EP23
Type 2
L (mm) | P (mm) | CODE
535 | 134... 560 | DS-EP24

Dimensions (mm)

Panel drilling for panel handle

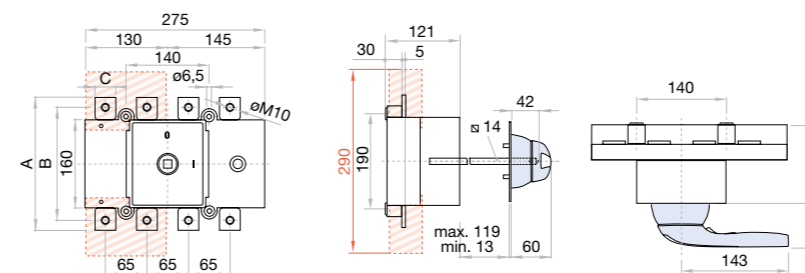
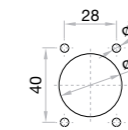

	A	B	C	S max (Cu) mm ²	H max (Cu) mm	L max (Cu) mm	T	M Nxm
500 A	220	190	25	2x185	6	40		
630 A	235	205	30	2x240	2x5	40	M10	24
800 A						50		

^{*(1)} Other voltages and / or utilization categories. Please consult
^{*(2)} Indicative values: current values vary from one motor manufacturer to another
^{*(3)} Without limiting protective device (short-circuit maintained 50... 100 ms.)
^{*(4)} With a protective device limiting the cut - off current and the joule integral to the indicated values
^{*(5)} Please consult us for more operations



S5000 AC Switch - disconnecter base mounting 3P - 3P+N

Size 3

A 800|1000|1250|2000



3P	CODE-800A	CODE-1000A	CODE-1250A	CODE-2000A
3P+N	S5-08003PRO S5-08003NRO	S5-10003PCO S5-10003NCO	S5-12503PCO S5-12503NCO	S5-20003PCO S5-20003NCO

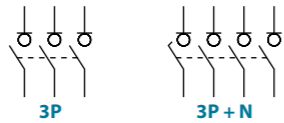

Technical information



According to IEC/EN 60947-3

			800	1000	1250	2000
Rated thermal current I _{th} in ambient at	40 °C	A	800	1000	1250	2000
	50 °C	A	800	1000	1125	1800
	60 °C	A	800	900	900	1600
Rated insulation voltage U _i		V	1000	1000	1000	1000
	Rated dielectric strength	50 Hz, 1 min.	V	8000	8000	8000
Rated impulse withstand voltage U _{imp}		kV	12	12	12	12
	AC rated operational current I _e (Rated operational frequency 50/60 Hz)	U _e 400V AC21A	A	800	1000	1250
AC rated operational power P _e	U _e 400V AC22A	A	800	1000	1250	2000 ^(*)
	U _e 400V AC23A	A	800	1000	1000	1400 ^(*)
	U _e 500V AC21A	A	800	1000	1250	2000
	U _e 500V AC22A	A	800	1000	1000	2000 ^(*)
Rated capacitor power	3x400V AC23A	kW	443,4	554,2	554,2	775,9
	400V, sen φ = 0,65	kVAr	360,2	450,3	450,3	630,4
Rated breaking capacity	400V AC23A	A	6400	8000	8000	11200
Rated making capacity	400V AC23A	A	8000	10000	10000	14000

			800	1000	1250	2000
Short - circuit behaviour						
Rated short-circuit making capacity I _{cm} kA (peak)		lcm kA (peak)	60	60	60	80
Rated short-time withstand current I _{cw} kA rms		l _{cw} kA rms	25	25	25	38
Conditional short - circuit current I _{cs} kA rms		kA rms	72	72	72	-
Maximum cut - off current I _{cu} kA (peak)		kA (peak)	55	55	55	-
Maximum power dissipation I ² t		A ² s (x10 ³)	4900	4900	4900	-
Mechanical features						
Minimum number of mechanical operations		Cycles	10000	10000	10000	10000
Maximum weight 3P		Kg	7	7	7	18,5
Maximum weight 3P+N		Kg	7,6	7,6	7,6	20

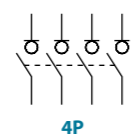

Also available 4P switches under request, consult reference

^(*) Other voltages and / or utilization categories. Please consult
^(*) Indicative values: current values vary from one motor manufacturer to another
^(*) Without limiting protective device (short-circuit maintained 50... 100 ms.)
^(*) With a protective device limiting the cut - off current and the joule integral to the indicated values
^(*) Please consult us for more operations
^(*) Rated operational current AC22B



Accessories



» Direct handle
 CODE DS-LI31
 CODE DS-LI41 (2000 A)



» Panel handle included shaft ^(*)
 IP65|UL50E/NEMA 250
 Types: 1, 3R, 4, 4X y 12
 CODE DS-LA31
 CODE DS-LA41 (2000 A)



» Panel handle without shaft
 IP65|UL50E/NEMA 250
 Types: 1, 3R, 4, 4X y 12
 CODE DS-LA33 (for 800-1000-1250A)



» Emergency panel handle included shaft ^(*)
 IP65|UL50E/NEMA 250
 Types: 1, 3R, 4, 4X y 12
 CODE DS-LR31
 CODE DS-LR41 (2000 A)

» Shafts

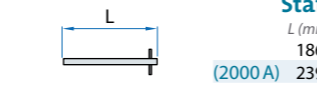

Standard shaft included ^(*)
 L (mm) P (mm)
 (2000 A) 186 145... 242
 239 145... 242

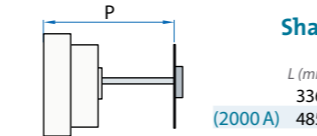

Shaft extensions
 Type 1
 L (mm) P (mm) CODE
 (2000 A) 336 145... 402 DS-EP32
 485 145... 244 DS-EP44
 Type 2
 L (mm) P (mm) CODE
 (2000 A) 535 145... 600 DS-EP24
 635 145... 600 DS-EP45

Dimensions (mm)

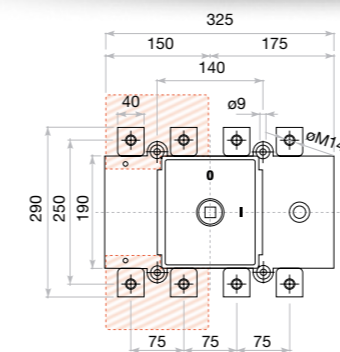

Panel drilling for panel handle

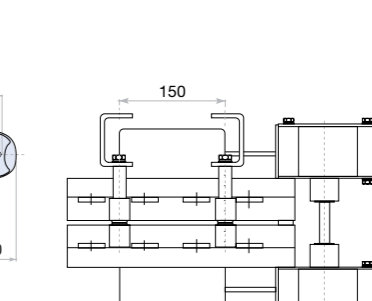
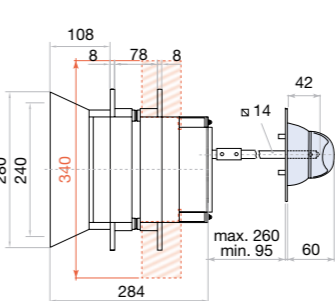
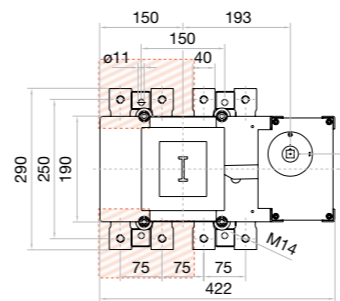
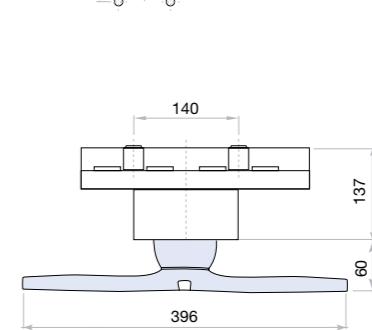
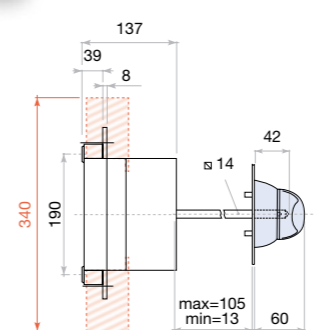

» Terminal shrouds



CODE DS-CU31
 (1 kit for input or output
 2000 A on frontal switch only)

» Auxiliary contacts



1NO+1NC CODE D5LAU01
 2NO+2NC CODE D5LAU02
 1NO+1NC CODE DS-AU11 (2000 A)
 2NO+2NC CODE DS-AU12 (2000 A)
 I_e = 16 A (resistive loads)
 4 A (inductive loads) at 250 Vac.

» Safety key lock device



Simple CODE DS-CB31
 Double CODE DS-CF31

For external handle, lock the handle by means of a key in position "OFF" (under request, in "ON"), the key can only be removed with the handle locked

Panel drilling for handle and keylock device
 Simple Double

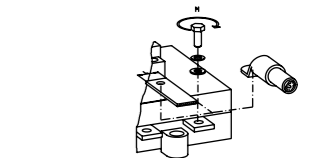
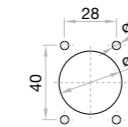
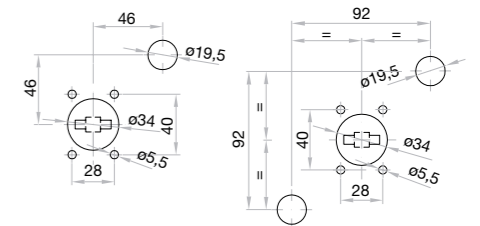

S max (Cu)	H max (Cu)	L max (Cu)	M
mm ²	mm	mm	Nxm
800 A	2x240	2x10	50 M14 45
1000 A	2x300		
1250 A			

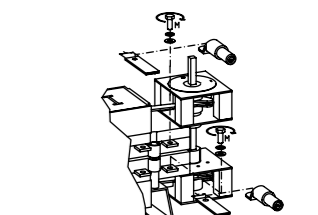

S max (Cu)	H max (Cu)	L max (Cu)	M
mm ²	mm	mm	Nxm
2000 A	4x300	4x10	50 M14 45

S5000 AC Switch - disconnecter base mounting 3P - 3P+N

Size 4

A 1000|1250|1600|1800|2000

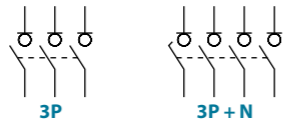
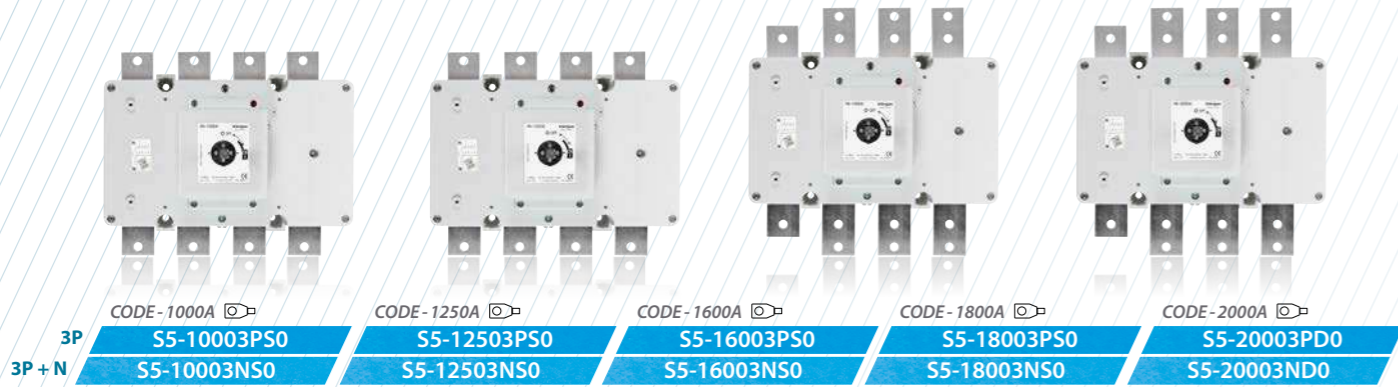

Technical information

According to IEC/EN 60947-3



		1000 1250 1600 1800 2000						
Rated thermal current in ambient at	Ith	40 °C	A	1000	1250	1600	1800	2000
		50 °C	A	1000	1250	1600	1620	1800
		60 °C	A	1000	1000	1440	1440	1600
Rated insulation voltage	Ui	V	1000	1000	1000	1000	1000	
Rated dielectric strength	50 Hz., 1 min.	V	10000	10000	10000	10000	10000	
Rated impulse withstand voltage	Uimp	kV	12	12	12	12	12	
AC rated operational current ^{*(1)} (Rated operational frequency 50/60 Hz)	le	Ue 400V AC21A	A	1000	1250	1600	1800	2000
		Ue 400V AC22A	A	1000	1250	1600	1800	2000
		Ue 400V AC23A	A	1000	1000	1000	1250	1250
		Ue 500V AC21A	A	1000	1250	1600	1800	2000
		Ue 500V AC22A	A	1000	1000	1250	1600	1800
	Ue 500V AC23A	A	800	800	900	1000 ^{*(5)}	1000 ^{*(5)}	

		1000 1250 1600 1800 2000						
AC rated operational power ^{*(2)}	Pe	3x400V AC23A	kW	554,2	554,2	554,2	692,8	692,8
Rated capacitor power	400V, sen φ = 0,65	kVAr	450,3	450,3	450,3	562,9	562,9	
Rated breaking capacity	400V AC23A	A	8000	8000	8000	10000	10000	
Rated making capacity	400V AC23A	A	10000	10000	10000	12500	12500	
Short - circuit behaviour								
Rated short-circuit making capacity ^{*(3)}	lcm	kA (peak)	60	60	75	75	75	
Rated short-time withstand current (1sec.)	lcw	kA rms	25	25	50	50	50	
Mechanical features								
Minimum number of mechanical operations ^{*(4)}	Cycles	10000	10000	4500	4500	4500		
Maximum weight 3P	Kg	18,5	18,5	18,5	18,5	18,5		
Maximum weight 3P + N	Kg	20,8	20,8	20,8	20,8	20,8		

^{*(1)} Other voltages and / or utilization categories. Please consult
^{*(2)} Indicative values: current values vary from one motor manufacturer to another
^{*(3)} Without limiting protective device (short-circuit maintained 50... 100 ms.)
^{*(4)} Please consult us for more operations
^{*(5)} Rated operational current AC22B

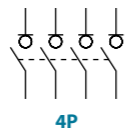

Also available 4P switches under request, consult reference



Accessories

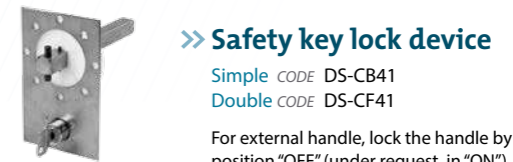
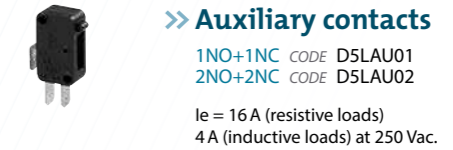

For external handle, lock the handle by means of a key in position "OFF" (under request, in "ON"), the key can only be removed with the handle locked

Panel drilling for handle and keylock device
Simple Double

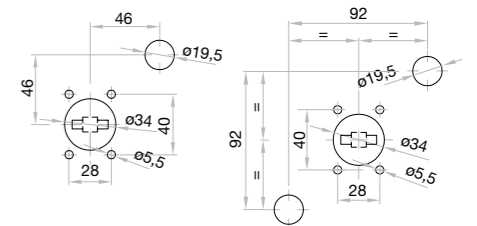

Shafts

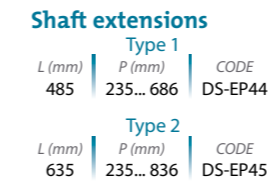

Dimensions (mm)

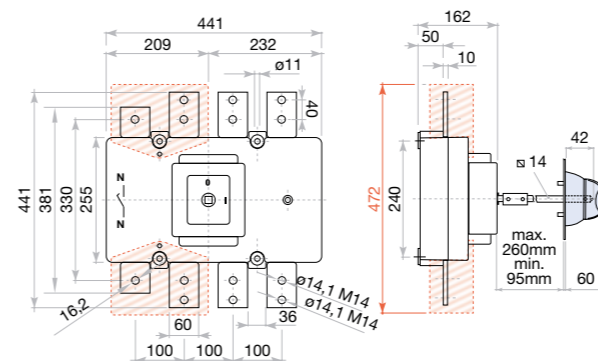
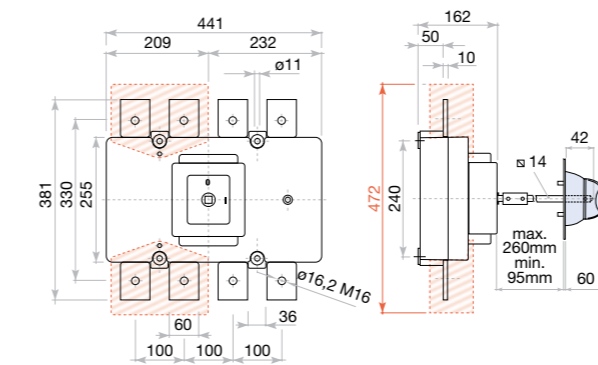

Panel drilling for panel handle

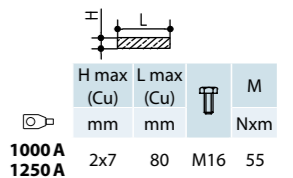
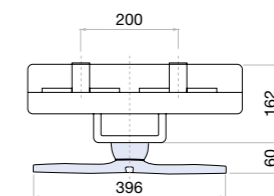
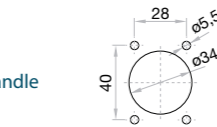

S5000 AC Switch - disconnecter base mounting 3P - 3P+N

Size 5

A 2000|2500|3150

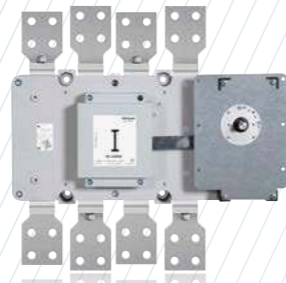

	CODE-2000A	CODE-2500A	CODE-3150A
3P	S5-20003PP0	S5-25003PP0	S5-31503PP0
3P + N	S5-20003NP0	S5-25003NP0	S5-31503NP0

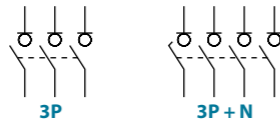

Technical information



According to IEC/EN 60947-3

		2000			2500			3150					
Rated thermal current in ambient at	Ith	40 °C	A	2000	2500	3150	50 °C	A	2000	2500	2835		
		50 °C	A	2000	2500	2835	60 °C	A	2000	2500	2520		
		60 °C	A	2000	2500	2520							
Rated insulation voltage	Ui	V			1000	1000	1000						
Rated dielectric strength	50 Hz, 1 min.	V			10000	10000	10000						
Rated impulse withstand voltage	Uimp	kV			8	8	8						
AC rated operational current ⁽¹⁾ (Rated operational frequency 50/60 Hz)	Ie	Ue 400V	AC21A	A	2000	2500	3150	Ue 400V	AC22A	A	2000	2500	2500 ⁽⁵⁾
		Ue 400V	AC23A	A	1600	1800	2000 ⁽⁵⁾	Ue 500V	AC21A	A	2000	2500	3150
		Ue 500V	AC22A	A	2000 ⁽⁵⁾	2200 ⁽⁵⁾	2200 ⁽⁵⁾	Ue 500V	AC23A	A	1250	1600 ⁽⁵⁾	1600 ⁽⁵⁾

		2000			2500			3150		
AC rated operational power ⁽²⁾	Pe	3x400V	AC23A	kW	886,8	997,6	1108,5			
Rated capacitor power	400V, sen φ = 0,65	kVAr	720,5	810,5	900,6					
Rated breaking capacity	400V	AC23A	A	12800	14400	16000				
Rated making capacity	400V	AC23A	A	16000	18000	20000				
Short - circuit behaviour										
Rated short-circuit making capacity ⁽³⁾	Icm	kA (peak)	100	100	100					
Rated short-time withstand current (1 sec.)	Icw	kA rms	50	50	50					
Mechanical features										
Minimum number of mechanical operations ⁽⁴⁾	Cycles	2500	2500	2500						
Maximum weight 3P	Kg	50	50	50						
Maximum weight 3P+N	Kg	58	58	58						

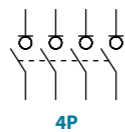

Also available 4P switches under request, consult reference

⁽¹⁾ Other voltages and / or utilization categories. Please consult
⁽²⁾ Indicative values: current values vary from one motor manufacturer to another
⁽³⁾ Without limiting protective device (short-circuit maintained 50... 100 ms.)
⁽⁴⁾ Please consult us for more operations
⁽⁵⁾ Rated operational current AC22B



Accessories



Direct handle
CODE DS-LI41



Panel handle included shaft ^(e1)
IP65|UL50E/NEMA 250
Types: 1, 3R, 4, 4X y 12
CODE DS-LA41



Panel handle without shaft
IP65|UL50E/NEMA 250
Types: 1, 3R, 4, 4X y 12
CODE DS-LA43



Emergency panel handle included shaft ^(e1)
IP65|UL50E/NEMA 250
Types: 1, 3R, 4, 4X y 12
CODE DS-LR41

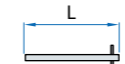

Shafts
Standard shaft included ^(e1)
L (mm) | P (mm)
239 | 420... 580

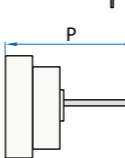

Auxiliary contacts
1NO+1NC CODE DS-AU11
2NO+2NC CODE DS-AU12
Ie = 16 A (resistive loads)
4 A (inductive loads) at 250 Vac.



Safety key lock device
Simple CODE DS-CB41
Double CODE DS-CF41
For external handle, lock the handle by means of a key in position "OFF" (under request, in "ON"), the key can only be removed with the handle locked

Panel drilling for handle and keylock device
Simple Double

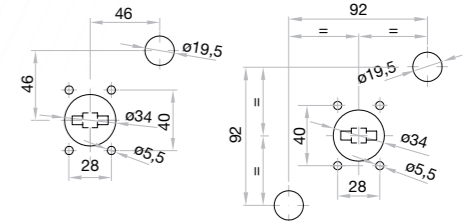

Dimensions (mm)

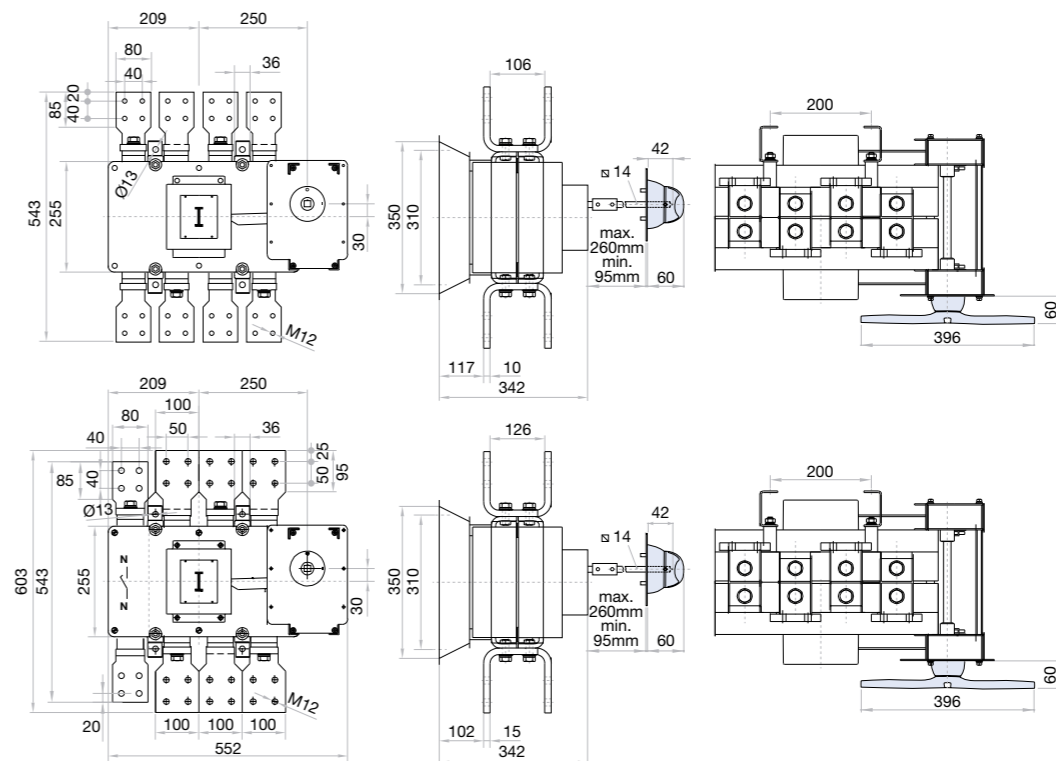

Panel drilling for panel handle

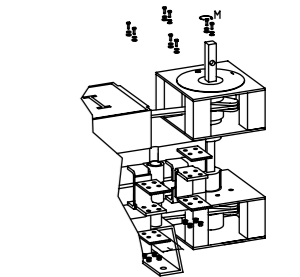
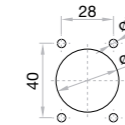

	H max (Cu)	L max (Cu)	M
2000 A	4x10	80	M12
2500 A	4x10	80	M12

	H max (Cu)	L max (Cu)	M
3150 A	4x10	100	M12

S5000 AC Switch - disconnecter base mounting 3P - 3P+N

Size 6

A 4000|5000|6300

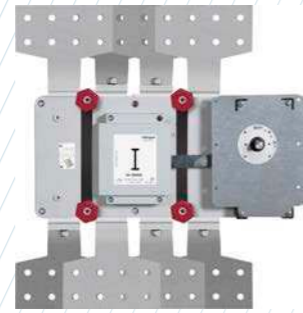

	CODE-4000A	CODE-5000A	CODE-6000A
3P	S5-40003PP0	S5-50003PP0	S5-60003PP0
3P + N	S5-40003NP0	S5-50003NP0	S5-60003NP0

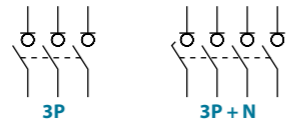

Technical information



According to IEC/EN 60947-3

			4000	5000	6300
Rated thermal current in ambient at	lth	40° C	A 4000	5000	6300
		50° C	A 4000	5000	5670
		60° C	A 3500	4400	5040
Rated insulation voltage	Ui		V 1000	1000	1000
Rated dielectric strength	50 Hz., 1 min.		V 10000	10000	10000
Rated impulse withstand voltage	Uimp	kV	12	12	12
AC rated operational current ^{*(1)} (Rated operational frequency 50/60 Hz)	Ie	Ue 400V AC21A	A 4000	5000	6300
		Ue 400V AC22A	A 3500	4000	4000
		Ue 400V AC23A	A 2000	2500	2500
		Ue 500V AC21A	A 3500	4000	5000
		Ue 500V AC22A	A 3150 ^{*(5)}	3150	3150
	Ue 500V AC23A	A 1600	1800	1800	

^{*(1)} Other voltages and / or utilization categories. Please consult
^{*(2)} Without limiting protective device (short-circuit maintained 50... 100 ms.)
^{*(3)} Indicative values: current values vary from one motor manufacturer to another
^{*(4)} Please consult us for more operations
^{*(5)} Rated operational current AC22B

			4000	5000	6300
AC rated operational power ^{*(2)}	Pe	3x400V AC23A	kW 1108,5	1385,6	1385,6
Rated capacitor power	400V, sen φ = 0,65	kVA	900,6	1125,8	1125,8
Rated breaking capacity	400V AC23A	A	16000	20000	20000
Rated making capacity	400V AC23A	A	20000	25000	25000
Short - circuit behaviour					
Rated short-circuit making capacity ^{*(3)}	Icm	kA (peak)	100	100	100
Rated short-time withstand current (1sec.)	Icw	kA rms	50	50	50
Mechanical features					
Minimum number of mechanical operations ^{*(4)}	Cycles		1500	1500	1500
Maximum weight 3P		Kg	100	130	130
Maximum weight 3P+N		Kg	110	140	140

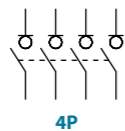

Also available 4P switches under request, consult reference



Accessories



Panel handle included shaft ^{*(e1)}
 (Slider bar)
 CODE DS-EN61



Auxiliary contacts
 1NO+1NC CODE DS-AU11
 2NO+2NC CODE DS-AU12
 Ie = 16 A (resistive loads)
 4 A (inductive loads) at 250 Vac.

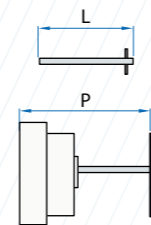

Shafts
 Standard shaft included ^{*(e1)}

L (mm)	P (mm)
333	578... 728
(2000 A) 333	720... 870



Safety key lock device
 Simple CODE DS-CS41
 Double CODE DS-CD41
 For external handle, lock the handle by means of a key in position "OFF" (under request, in "ON"), the key can only be removed with the handle locked

Panel drilling for handle and keylock device
 Simple Double

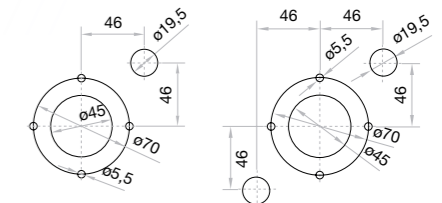

Dimensions (mm)

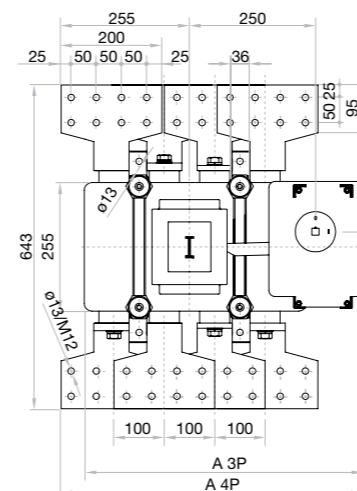

Panel drilling for panel handle

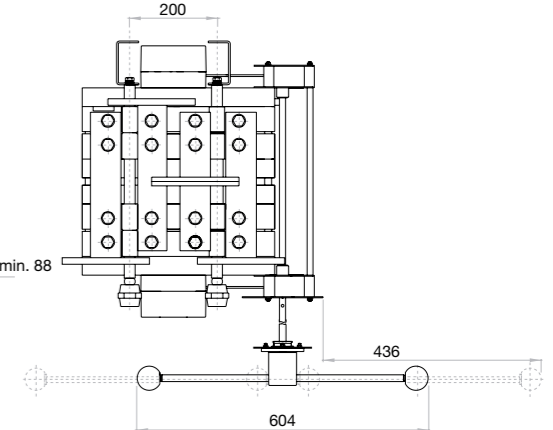
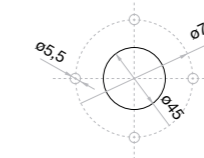
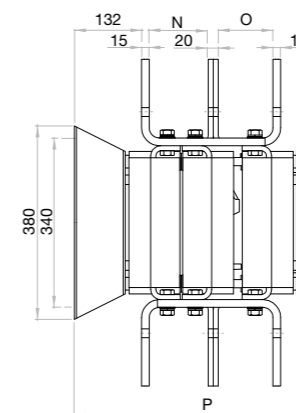

	A		N	O	P	φ
	3P	4P				
4000 A	551,5	597,5	116	107,5	502,5	13
5000 A	551,5	597,5	164,5	164,5	632	
6300 A						

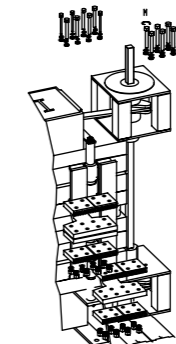

H max (Cu)	L max (Cu)	M
mm	mm	Nxm
4000 A	4x10	
5000 A	100	M12 45
6300 A	6x10	

S5000M AC Switch - disconnecter base mounting 6P - 8P

Size 0
A 125|160|200

	CODE-125A	CODE-160A	CODE-200A
6P	S5M01256PS0	S5M01606PS0	S5M02006PS0
8P	S5M01258PS0	S5M01608PS0	S5M02008PS0

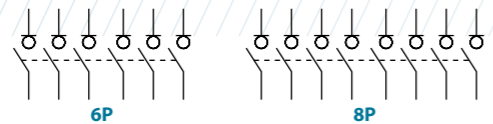

Technical information



According to IEC/EN 60947-3

		125			160			200		
Rated thermal current in ambient at	I _{th}	40 °C	A	125	160	200				
		50 °C	A	125	160	200				
		60 °C	A	125	160	200				
Rated insulation voltage	U _i	V	1000	1000	1000					
Rated dielectric strength	50 Hz, 1 min.	V	4000	4000	4000					
Rated impulse withstand voltage	U _{imp}	kV	8	8	8					
AC rated operational current ^{*(1)} (Rated operational frequency 50/60 Hz)	I _e	U _e 400V	AC21A	A	125	160	200			
		U _e 400V	AC22A	A	125	160	200			
		U _e 400V	AC23A	A	125	160	160			
		U _e 500V	AC21A	A	125	160	200			
		U _e 500V	AC22A	A	125	160	200			
U _e 500V	AC23A	A	100	125	125					
AC rated operational power ^{*(2)}	P _e	3x400V	AC23A	kW	69,2	88,6	88,6			
Rated capacitor power	400V, sen φ = 0,65	kVAR	56,2	72	72					
Rated breaking capacity	400V	AC23A	A	1000	1280	1280				
Rated making capacity	400V	AC23A	A	1250	1600	1600				

^{*(1)} Other voltages and / or utilization categories. Please consult
^{*(2)} Indicative values: current values vary from one motor manufacturer to another
^{*(3)} Without limiting protective device (short-circuit maintained 50... 100 ms.)
^{*(4)} With a protective device limiting the cut - off current and the joule integral to the indicated values
^{*(5)} Please consult us for more operations

		125			160			200		
Short - circuit behaviour										
Rated short-circuit making capacity ^{*(3)}	I _{cm} kA (peak)	13	13	13						
Rated short-time withstand current (1sec.)	I _{cw} kA rms	7	7	7						
Conditional short - circuit current (rms value) ^{*(4)}	kA rms	100	100	100						
Maximum cut - off current (peak value)	kA (peak)	17	20	20						
Maximum power dissipation (I ² t)	A ² s (x10 ³)	55	198	198						
Mechanical features										
Minimum number of mechanical operations ^{*(5)}	Cycles	30000	30000	30000						
Maximum weight 6P		1,8	1,8	1,9						
Maximum weight 8P		2,1	2,1	2,2						

Accessories

- Direct handle**
CODE DS-SI01
- Panel handle** included shaft ^{*(e1)}
IP65
CODE DS-LA01
- Emergency panel handle** included shaft ^{*(e1)}
IP65
CODE DS-LR01
- Terminal protection**
CODE DS-CU01
(1 unit for input or output only frontal side)
- Auxiliary contacts**
1NO+1NC CODE DS-AU11
2NO+2NC CODE DS-AU12
I_e = 16 A (resistive loads)
4 A (inductive loads) at 250 Vac.
- Safety key lock devices**
Simple CODE DS-CAB1
Double CODE DS-CEB1

Shafts

Standard shaft included ^{*(e1)}
L (mm) 177 P (mm) 155... 263

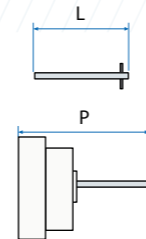

Dimensions (mm)

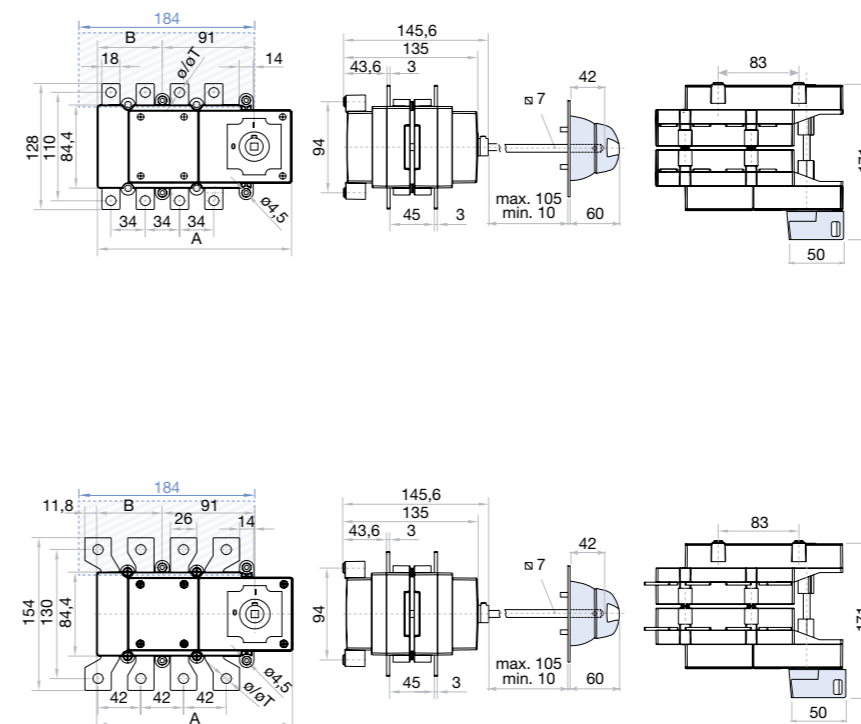

Panel drilling for panel handle

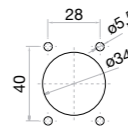

Panel drilling for handle and keylock device
Simple Double

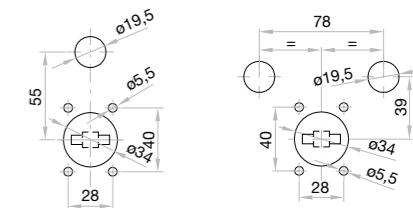

A	B	φ	S max (Cu)		H max (Cu)		L max (Cu)		M	
			mm ²	mm	mm	mm				
125 A	181	192	53	64	10	95	5	25	M8	13

A	B	φ	S max (Cu)		H max (Cu)		L max (Cu)		M		
			mm ²	Z max	mm	mm					
200 A	181	192	53	64	10	120	30	5	30	M10	18

S5000M AC Switch - disconnecter base mounting 6P - 8P

Size 1
A 250|315|400

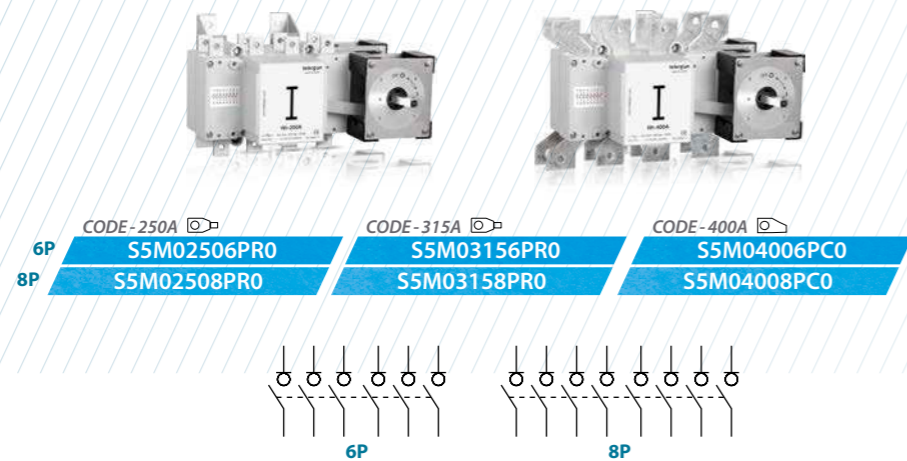

Technical information



According to IEC/EN 60947-3

		250			315			400		
Rated thermal current in ambient at	Ith	40 °C	A	250	315	400				
		50 °C	A	250	315	400				
		60 °C	A	250	315	320				
Rated insulation voltage	Ui	V			1000	1000	1000			
Rated dielectric strength	50 Hz., 1 min.	V			5000	5000	5000			
Rated impulse withstand voltage	Uimp	kV			8	8	8			
AC rated operational current ^{*(1)} (Rated operational frequency 50/60 Hz)	Ie	Ue 400V	AC21A	A	250	315	400			
		Ue 400V	AC22A	A	250	315	400			
		Ue 400V	AC23A	A	250	315	400			
		Ue 500V	AC21A	A	250	315	400			
		Ue 500V	AC23A	A	200	250	315			
AC rated operational power ^{*(2)}	Pe	3x400V	AC23A	kW	138,5	174,5	221,7			
Rated capacitor power	400V, sen φ = 0,65	kVAr	112,5	141,8	180,1					
Rated breaking capacity	400V	AC23A	A	2000	2520	3200				
Rated making capacity	400V	AC23A	A	2500	3150	4000				

		250			315			400		
Short - circuit behaviour										
Rated short-circuit making capacity ^{*(3)}	Icm	kA (peak)	20	20	20					
Rated short-time withstand current (1sec.)	Icw	kA rms	12	12	12					
Conditional short - circuit current (rms value) ^{*(4)}	Ics	kA rms	100	100	100					
Maximum cut - off current (peak value)	Icu	kA (peak)	33	33	33					
Maximum power dissipation (I ² t)	I ² t	A ² s (x10 ³)	1000	1000	1000					
Mechanical features										
Minimum number of mechanical operations ^{*(5)}	Cycles	20000	20000	20000						
Maximum weight 6P	Weight	Kg	5,5	5,5	5,7					
Maximum weight 8P	Weight	Kg	5,8	5,8	6					

^{*(1)} Other voltages and / or utilization categories. Please consult
^{*(2)} Indicative values: current values vary from one motor manufacturer to another
^{*(3)} Without limiting protective device (short-circuit maintained 50... 100 ms.)
^{*(4)} With a protective device limiting the cut - off current and the joule integral to the indicated values
^{*(5)} Please consult us for more operations

Accessories

- Direct handle**
CODE DS-LI12
- Panel handle** included shaft ^{*(e1)}
IP65|UL50E/NEMA 250
Types: 1, 3R, 4, 4X y 12
CODE DS-LA12
- Panel handle** without shaft
IP65|UL50E/NEMA 250
Types: 1, 3R, 4, 4X y 12
CODE DS-LA15
- Emergency panel handle** included shaft ^{*(e1)}
IP65|UL50E/NEMA 250
Types: 1, 3R, 4, 4X y 12
CODE DS-LR12
- Terminal protection**
CODE DS-CU12
(1 unit for input or output only frontal side)
- Terminal shrouds**
CODE DS-CU11
(1 kit for input or output only frontal side)
- Safety key lock devices**
Simple CODE DS-CB12
Double CODE DS-CF11
For external handle, lock the handle by means of a key in position "OFF" (under request, in "ON"), the key can only be removed with the handle locked
Panel drilling for handle and keylock device
Simple Double
- Shafts**
Standard shaft included ^{*(e1)}
L (mm) | P (mm)
277 | 288... 422
- Auxiliary contacts**
1NO+1NC CODE DS-AU11
2NO+2NC CODE DS-AU12
Ie = 16 A (resistive loads)
4 A (inductive loads) at 250 Vac.

Dimensions (mm)

Panel drilling for panel handle

	S max (Cu) mm ²	H max (Cu) mm	L max (Cu) mm	T	M
250 A 315 A	185	7	25	M10	18
400 A	240	7	40	M10	24

S5000M AC Switch - disconnecter base mounting 6P - 8P

Size 2
A 500|630

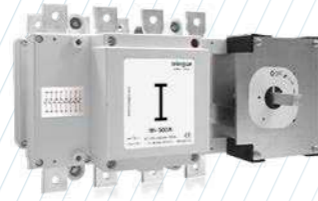

6P	CODE-500A	S5M05006PR0	S5M06306PR0
8P		S5M05008PR0	S5M06308PR0

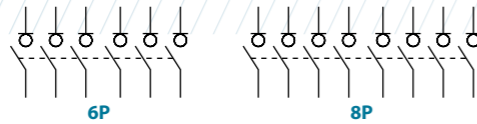

Technical information



According to IEC/EN 60947-3

		500		630	
Rated thermal current in ambient at	I _{th}	40 °C	A	500	630
		50 °C	A	500	630
		60 °C	A	500	630
Rated insulation voltage	U _i	V		1000	1000
Rated dielectric strength	50 Hz., 1 min.	V		8000	8000
Rated impulse withstand voltage	U _{imp}	kV		12	12
AC rated operational current ^{*(1)} (Rated operational frequency 50/60 Hz)	I _e	U _e 400V AC21A	A	500	630
		U _e 400V AC22A	A	500	630
		U _e 400V AC23A	A	500	630
		U _e 500V AC21A	A	500	630
		U _e 500V AC22A	A	500	630
		U _e 500V AC23A	A	400	500
AC rated operational power ^{*(2)}	P _e	3x400V AC23A	kW	277,1	349,1
Rated capacitor power		400V, sen φ = 0,65	kVA _r	225,1	283,7
Rated breaking capacity		400V AC23A	A	4000	5000
Rated making capacity		400V AC23A	A	5000	6300

		500		630	
Short - circuit behaviour					
Rated short-circuit making capacity ^{*(3)}	I _{cm}	kA (peak)	26	26	
Rated short-time withstand current (1sec.)	I _{cw}	kA rms	16	16	
Conditional short - circuit current (rms value) ^{*(4)}		kA rms	100	100	
Maximum cut - off current (peak value)		kA (peak)	39	39	
Maximum power dissipation (I ² t)		A ² s (x10 ³)	1600	1600	
Mechanical features					
Minimum number of mechanical operations ^{*(5)}		Cycles	10000	10000	
Maximum weight 6P		Kg	12,3	12,3	
Maximum weight 8P		Kg	13	13	

^{*(1)} Other voltages and / or utilization categories. Please consult
^{*(2)} Indicative values: current values vary from one motor manufacturer to another
^{*(3)} Without limiting protective device (short-circuit maintained 50... 100 ms.)
^{*(4)} With a protective device limiting the cut - off current and the joule integral to the indicated values
^{*(5)} Please consult us for more operations

Accessories



Direct handle
CODE DS-LI22



Panel handle included shaft ^{*(e1)}
IP65|UL50E/NEMA 250
Types: 1, 3R, 4, 4X y 12
CODE DS-LA22

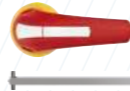

Emergency panel handle included shaft ^{*(e1)}
IP65|UL50E/NEMA 250
Types: 1, 3R, 4, 4X y 12
CODE DS-LR22

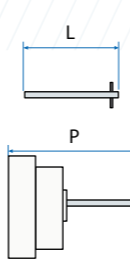

Standard shaft included ^{*(e1)}
L (mm) | P (mm)
239 | 325... 490



Terminal shrouds
CODE DS-CU21
(1 kit for input or output only frontal side)



Auxiliary contacts
1NO+1NC CODE DS-AU11
2NO+2NC CODE DS-AU12
I_e = 16 A (resistive loads)
4 A (inductive loads) at 250 Vac.



Safety key lock devices
Simple CODE DS-CB21
Double CODE DS-CF21
For external handle, lock the handle by means of a key in position "OFF" (under request, in "ON"), the key can only be removed with the handle locked

Panel drilling for handle and keylock device
Simple Double

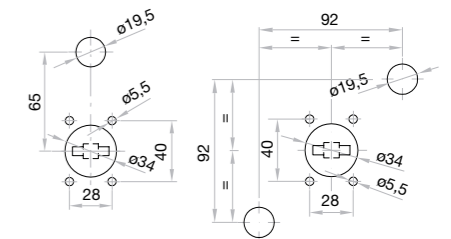

Dimensions (mm)

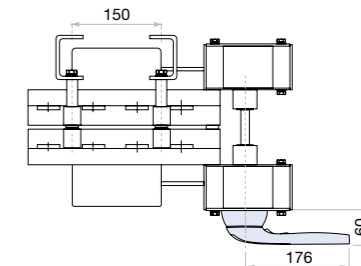
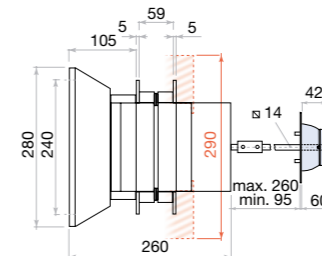
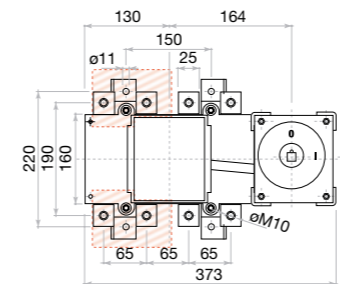

S max (Cu)	H max (Cu)	L max (Cu)	M
mm ²	mm	mm	Nxm
500 A	2x185	6	40 M10 24

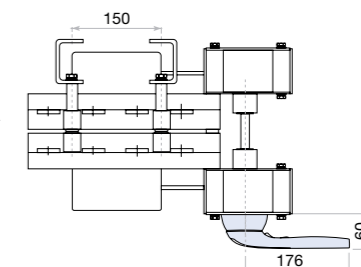
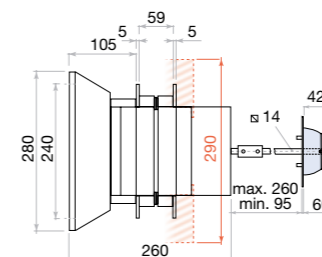
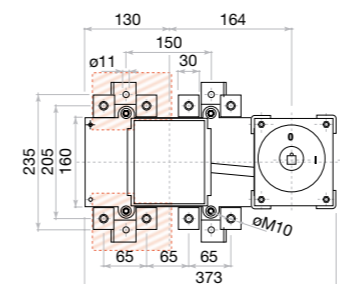

S max (Cu)	H max (Cu)	L max (Cu)	M
mm ²	mm	mm	Nxm
630 A	2x240	2x5	40 M10 24

S5000M AC Switch - disconnecter base mounting 6P - 8P

Size 3
A 800 | 1000

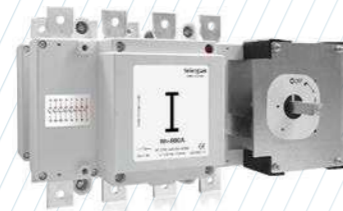

6P	CODE-800A	S5M08006PRO	S5M10006PCO
8P	CODE-1000A	S5M08008PRO	S5M10008PCO

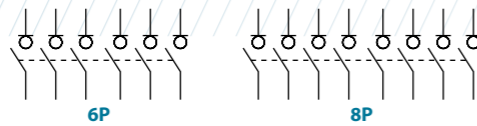

Technical information



According to IEC/EN 60947-3

		800		1000		
Rated thermal current in ambient at	I _{th}	40 °C	A	800	1000	
		50 °C	A	800	1000	
		60 °C	A	800	900	
Rated insulation voltage	U _i	V		1000	1000	
Rated dielectric strength	50 Hz., 1 min.	V		8000	8000	
Rated impulse withstand voltage	U _{imp}	kV		12	12	
AC rated operational current ^{*(1)}	I _e	U _e 400V	AC21A	A	800	1000
		U _e 400V	AC22A	A	800	1000
		U _e 400V	AC23A	A	800	1000
		U _e 500V	AC21A	A	800	1000
		U _e 500V	AC22A	A	800	1000
(Rated operational frequency 50/60 Hz)		U _e 500V	AC23A	A	800	800
AC rated operational power ^{*(2)}	P _e	3x400V	AC23A	kW	443,4	554,2
Rated capacitor power	400V, sen φ = 0,65	kVAr	360,2	450,3		
Rated breaking capacity	400V	AC23A	A	6400	8000	
Rated making capacity	400V	AC23A	A	8000	10000	

^{*(1)} Other voltages and / or utilization categories. Please consult
^{*(2)} Indicative values: current values vary from one motor manufacturer to another
^{*(3)} Without limiting protective device (short-circuit maintained 50... 100 ms.)
^{*(4)} With a protective device limiting the cut - off current and the joule integral to the indicated values
^{*(5)} Please consult us for more operations

		800		1000	
Short - circuit behaviour					
Rated short-circuit making capacity ^{*(3)}	I _{cm}	kA (peak)	60	60	
Rated short-time withstand current (1sec.)	I _{cw}	kA rms	25	25	
Conditional short - circuit current (rms value) ^{*(4)}	I _{cs}	kA rms	72	72	
Maximum cut - off current (peak value)		kA (peak)	55	55	
Maximum power dissipation (I ² t)		A ² s (x10 ³)	4900	4900	
Mechanical features					
Minimum number of mechanical operations ^{*(5)}	Cycles		10000	10000	
Maximum weight 6P		Kg	18,5	18,5	
Maximum weight 8P		Kg	20	20	

Accessories

Direct handle
CODE DS-LI41

Panel handle included shaft ^{*(e1)}
IP65|UL50E/NEMA 250
Types: 1, 3R, 4, 4X y 12
CODE DS-LA41

Panel handle without shaft
IP65|UL50E/NEMA 250
Types: 1, 3R, 4, 4X y 12
CODE DS-LA43

Emergency panel handle included shaft ^{*(e1)}
IP65|UL50E/NEMA 250
Types: 1, 3R, 4, 4X y 12
CODE DS-LR41

Shafts
Standard shaft included ^{*(e1)}
L (mm) | P (mm) |
239 | 408... 573

Terminal shrouds
CODE DS-CU31
(1 kit for input or output only frontal side)

Auxiliary contacts
1NO+1NC CODE DS-AU11
2NO+2NC CODE DS-AU12
I_e = 16 A (resistive loads)
4 A (inductive loads) at 250 Vac.

Safety key lock devices
Simple CODE DS-CB41
Double CODE DS-CF41
For external handle, lock the handle by means of a key in position "OFF" (under request, in "ON"), the key can only be removed with the handle locked
Panel drilling for handle and keylock device
Simple Double

Dimensions (mm)

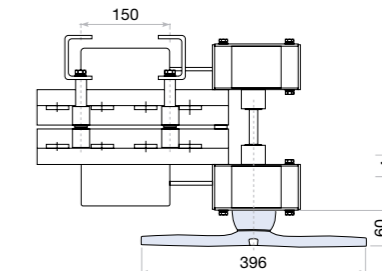
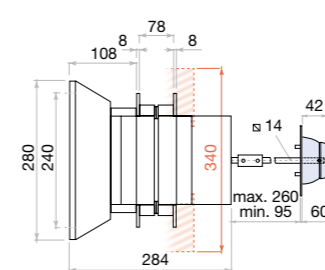
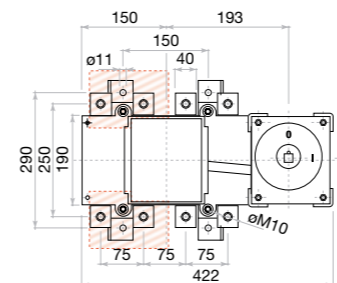

	S max (Cu)	H max (Cu)	L max (Cu)	T	M
	mm ²	mm	mm		Nxm
800 A	2x240	2x5	50	M14	45
1000 A	2x300	2x10			

S5000M AC Switch - disconnecter base mounting 6P - 8P

Size 4
A 1250|1600|1800|2000

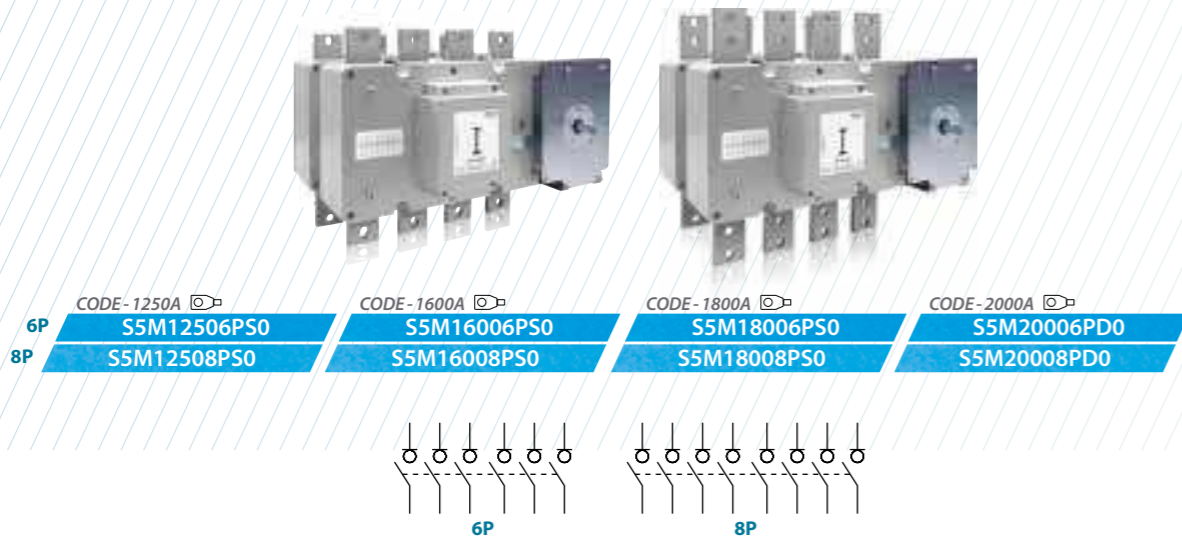

Technical information



According to IEC/EN 60947-3

		1250 1600 1800 2000				
Rated thermal current in ambient at	lth	40 °C	A 1250	1600	1800	2000
		50 °C	A 1250	1600	1620	1800
		60 °C	A 1000	1440	1440	1600
Rated insulation voltage	Ui	V	1000	1000	1000	1000
Rated dielectric strength	50 Hz, 1 min.	V	10000	10000	10000	10000
Rated impulse withstand voltage	Uimp	kV	12	12	12	12
AC rated operational current ⁽¹⁾	Ue 400V AC21A	A	1250	1600	1800	2000
	Ue 400V AC22A	A	1250	1600	1800	2000
	Ue 400V AC23A	A	1000	1000	1250	1250
	Ue 500V AC21A	A	1250	1600	1800	2000
	Ue 500V AC22A	A	1000	1250	1600	1800
	Ue 500V AC23A	A	800	900	1000 ⁽⁵⁾	1000 ⁽⁵⁾

		1250 1600 1800 2000					
AC rated operational power	Pe	3x400V AC23A	kW	554,2	554,2	692,8	692,8
Rated capacitor power	400V, sen φ = 0,65	kVAr	450,3	450,3	562,9	562,9	
Rated breaking capacity	400V AC23A	A	8000	8000	10000	10000	
Rated making capacity	400V AC23A	A	10000	10000	12500	12500	
Short - circuit behaviour							
Rated short-circuit making capacity ⁽³⁾	lcm	kA (peak)	60	75	75	75	
Rated short-time withstand current (1 sec.)	lcw	kA rms	25	50	50	50	
Mechanical features							
Minimum number of mechanical operations ⁽⁴⁾	Cycles	10000	4500	4500	4500		
Maximum weight 6P	Kg	42,9	42,9	42,9	42,9		
Maximum weight 8P	Kg	47,3	47,3	47,3	47,3		

⁽¹⁾ Other voltages and / or utilization categories. Please consult
⁽²⁾ Indicative values: current values vary from one motor manufacturer to another
⁽³⁾ Without limiting protective device (short-circuit maintained 50... 100 ms.)
⁽⁴⁾ Please consult us for more operations
⁽⁵⁾ Rated operational current AC22B

Accessories



Direct handle
CODE DS-LI41



Panel handle included shaft ^(e1)
IP65|UL50E/NEMA 250
Types: 1, 3R, 4, 4X y 12
CODE DS-LA41



Panel handle without shaft
IP65|UL50E/NEMA 250
Types: 1, 3R, 4, 4X y 12
CODE DS-LA43



Emergency panel handle included shaft ^(e1)
IP65|UL50E/NEMA 250
Types: 1, 3R, 4, 4X y 12
CODE DS-LR41



Terminal shrouds
CODE DS-CU41
(1 kit for input or output only frontal side)



Auxiliary contacts
1NO+1NC CODE DS-AU11
2NO+2NC CODE DS-AU12
Ie = 16 A (resistive loads)
4 A (inductive loads) at 250 Vac.



Safety key lock devices
Simple CODE DS-CB41
Double CODE DS-CF41
For external handle, lock the handle by means of a key in position "OFF" (under request, in "ON"), the key can only be removed with the handle locked

Panel drilling for handle and keylock device
Simple Double

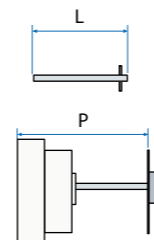

Shafts
Standard shaft included ^(e1)
L (mm) | P (mm) |
239 | 408... 573

Dimensions (mm)

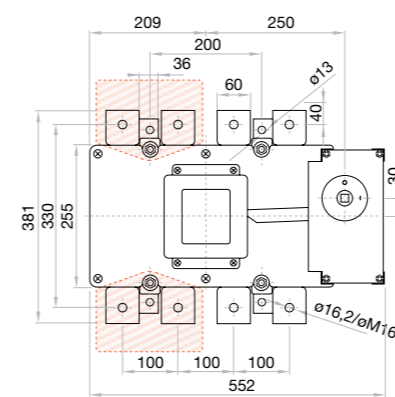

Panel drilling for panel handle

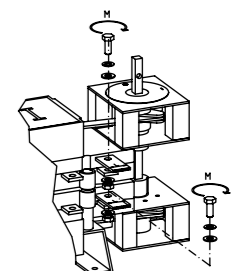
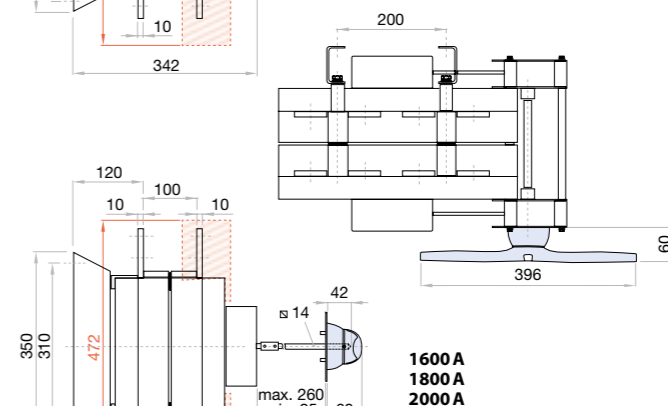
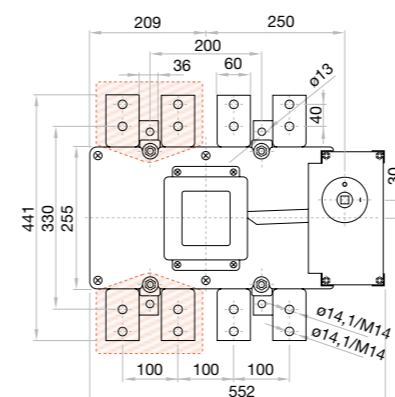
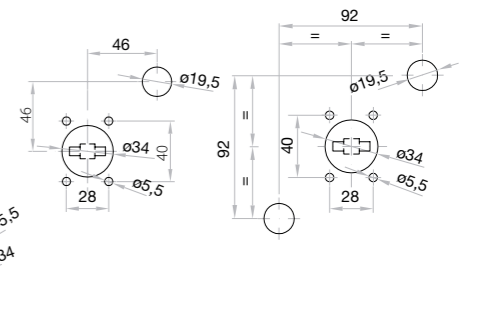
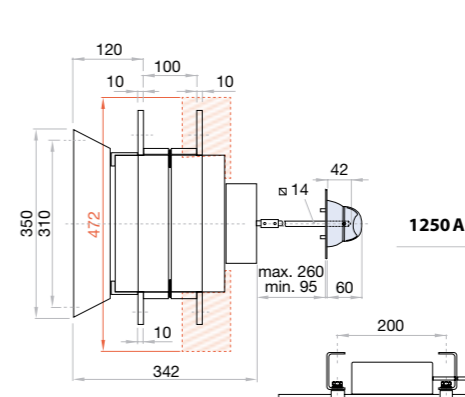

	H max (Cu) mm	L max (Cu) mm	T M Nxm
1250 A			M16 80
1600 A	2x7	80	M14 55
1800 A			
2000 A			

S6000 AC Switch - disconnecter base mounting 2P - 3P - 3P+N

Size 1
A 200|250|315|400

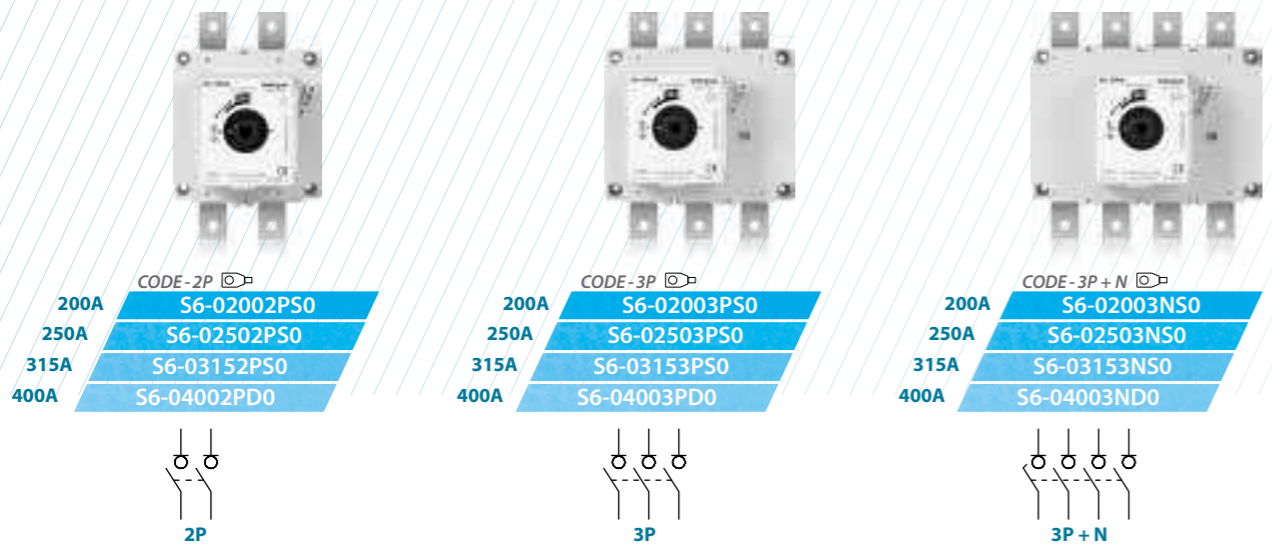

CODE - 2P

200A	S6-02002PS0
250A	S6-02502PS0
315A	S6-03152PS0
400A	S6-04002PD0

CODE - 3P

200A	S6-02003PS0
250A	S6-02503PS0
315A	S6-03153PS0
400A	S6-04003PD0

CODE - 3P+N

200A	S6-02003NS0
250A	S6-02503NS0
315A	S6-03153NS0
400A	S6-04003ND0

Technical information

According to IEC / EN 60947-3



		200	250	315	400	
Rated thermal current in ambient at	Ith 40° C	A	200	250	315	400
	50° C	A	200	250	315	400
	60° C	A	200	250	315	400
Rated insulation voltage	Ui	V	1000	1000	1000	1000
Rated dielectric strength	50 Hz, 1 min.	V	5000	5000	5000	5000
Rated impulse withstand voltage	Uimp	kV	12	12	12	12
AC Rated operational current ^{*(1)}	Monophasic	AC21A A	200	250	315	400
		AC22A A	200	250	315	400
	Triphasic	AC21A A	200	250	315	400
		AC22A A	200	250	315	400
AC rated operational power ^{*(2)}	3x400V	AC23A kW	110,8	138,5	174,5	221,7
Rated capacitor power	400V, sen φ=0,65	kVA	90	112,5	141,8	180,1
Rated breaking capacity	400V, cos φ=0,35-0,45	A	1600	2000	2520	3200
Rated making capacity	400V, cos φ=0,45	A	2000	2500	3150	4000

		200	250	315	400
Short - circuit behaviour					
Rated short-circuit making capacity ^{*(3)}	Icm kA (peak)	20	20	20	20
Rated short-time withstand current (1sec)	Icw kA rms	12	12	12	12
Conditional short - circuit current ^{*(4)}	kA rms	100	100	100	100
Maximum cut - off current	kA (peak)	33	33	33	33
Maximum power dissipation	A²s (x10³)	1000	1000	1000	1000
Mechanical features					
Minimum number of mechanical operations ^{*(5)}	Cycles	20000	20000	20000	20000
Maximum weight 2P	kg	1,65	1,65	1,65	1,68
Maximum weight 3P	kg	2,17	2,17	2,17	2,21
Maximum weight 3P+N	kg	2,70	2,70	2,70	2,76

^{*(1)} Other voltages and / or utilization categories. Please consult
^{*(2)} Reference values, the associated current depends on motor manufacturer
^{*(3)} Without limiting protective device (short-circuit maintained 50... 100 ms.)
^{*(4)} With limiting protective device which set a limit to peak value short-circuit making capacity and maximum power dissipation to indicated values
^{*(5)} Please consult us for more operations

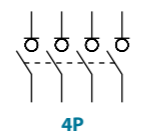

Also available 4P switches under request, consult reference



Accessories

- Direct handle**
CODE DS-SI1
- Panel handle** included shaft ^{*(e1)}
IP65|UL50E/NEMA 250
Types: 1, 3R, 4, 4X y 12
CODE DS-SA11
- Panel handle** without shaft
IP65|UL50E/NEMA 250
Types: 1, 3R, 4, 4X y 12
CODE DS-SA14
- Emergency panel handle** included shaft ^{*(e1)}
IP65|UL50E/NEMA 250
Types: 1, 3R, 4, 4X y 12
CODE DS-SR11
- Shafts**
Standard shaft included ^{*(e1)}
L (mm) | P (mm) | CODE
227 | 103... 256 |
Shaft extensions
Type 1
L (mm) | P (mm) | CODE
375 | 103... 415 | DS-EP14
Type 2
L (mm) | P (mm) | CODE
536 | 103... 576 | DS-EP15
- Auxiliary contacts**
1NO+1NC CODE D5LAU01
2NO+2NC CODE D5LAU02
Ie = 16 A (resistive loads)
4 A (inductive loads) at 250 Vac.

- Terminal shrouds**
CODE DR-CU11 (1 unit)
CODE DR-CU12 (1 unit)
CODE DR-CU13 (1 unit)
- Phase barriers**
CODE DR-SF11 (1 unit)
CODE DR-SF12 (2 units)
CODE DR-SF13 (3 units)
- Spacers**
CODE DR-EL11 (4 units)
- Safety key lock device**
Simple CODE DS-CA11
Double CODE DS-CE11
For external handle, lock the handle by means of a key in position "OFF" (under request, in "ON"), the key can only be removed with the handle locked

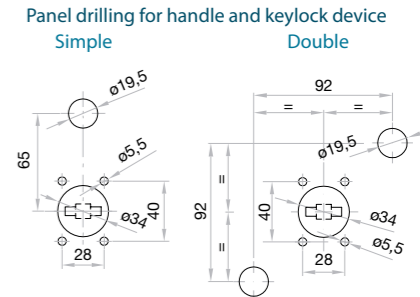

Dimensions (mm)

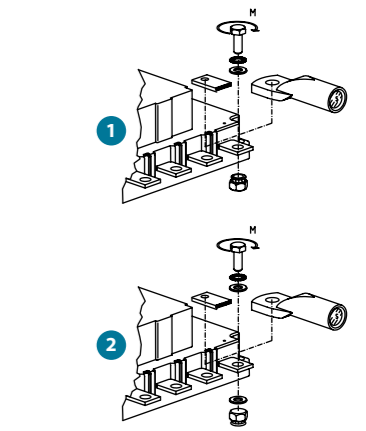
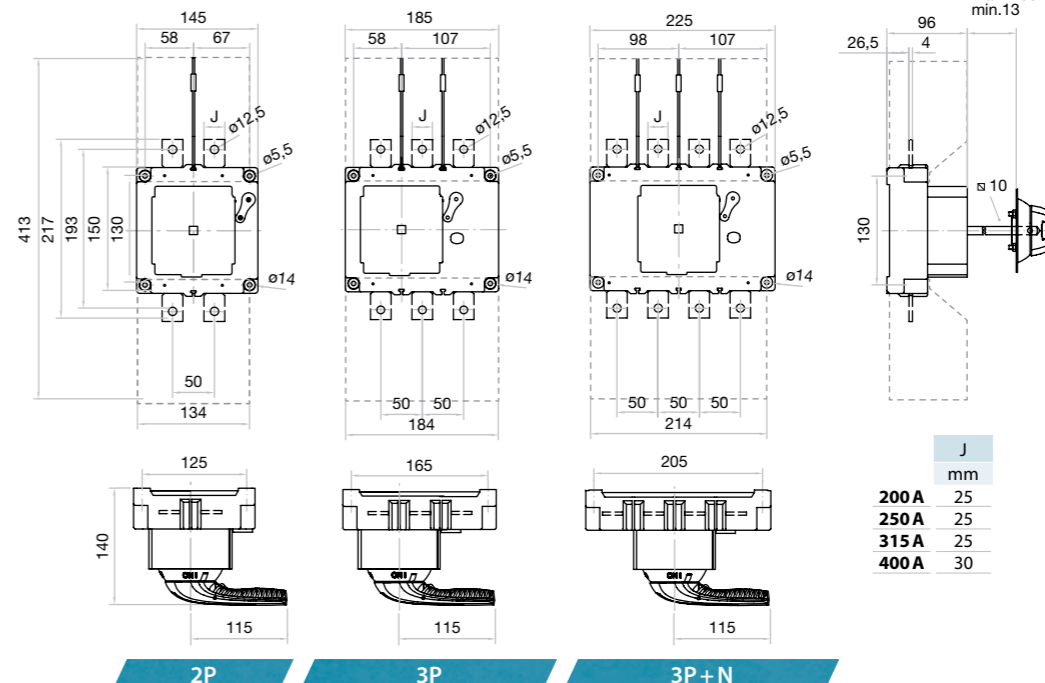

	S max (Cu) mm²	H max (Cu) mm	L max (Cu) mm	T M
200 A	120	7	25	M10 18
250 A	150	7	25	M10 18
315 A	185 ^{*(6)}	7	25	M10 18
400 A	240 ^{*(6)}	7	35 ^{*(6)}	M10 18

^{*(6)} Using phase barriers DR-SF__ to maintain the required clearance.

S6000 AC Switch - disconnecter base mounting 2P - 3P - 3P+N

Size 2
A 500|630|800

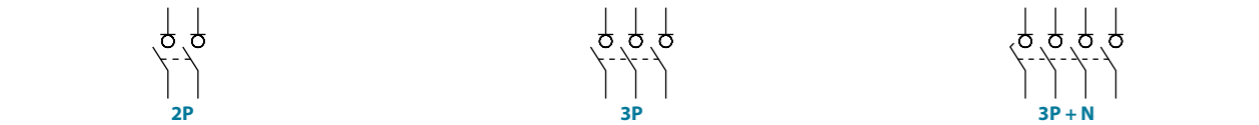
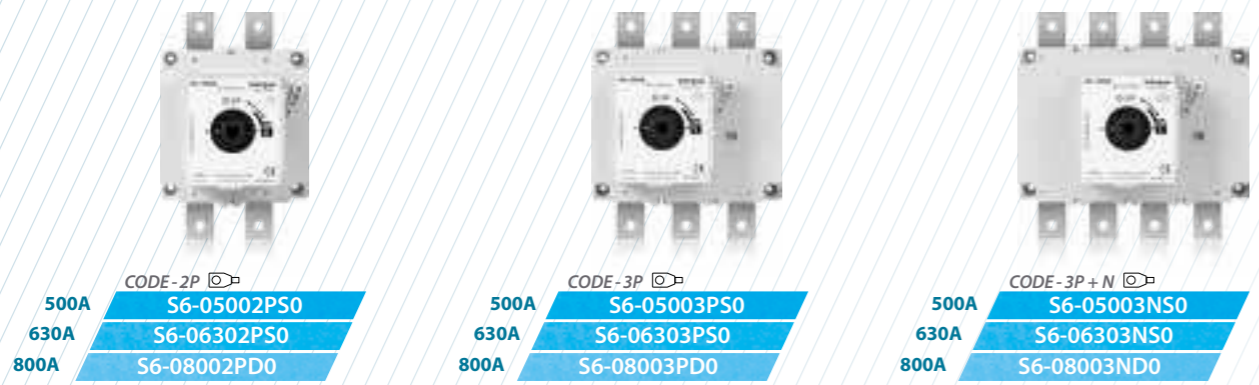

Technical information



According to IEC / EN 60947-3

			500	630	800
Rated thermal current in ambient at	I _{th}	40° C	A 500	630	800
		50° C	A 500	630	800
		60° C	A 500	630	800
Rated insulation voltage	U _i		V 1000	1000	1000
Rated dielectric strength		50 Hz., 1 min.	V 8000	8000	8000
Rated impulse withstand voltage	U _{imp}		kV 12	12	12
AC Rated operational current ^{*(1)}	I _e	Monophasic 400V AC21A	A 500	630	800
		AC22A	A 500	630	800
		AC21A	A 500	630	800
		Triphasic 400V AC22A	A 500	630	800
		AC23A	A 500	630	800
AC rated operational power ^{*(2)}	P _e	3x400V AC23A	kW 277,1	349,2	443,4
Rated capacitor power		400V, sen φ=0,65	kVAr 225,2	283,7	360,3
Rated breaking capacity		400V, cos φ=0,35-0,45	A 4000	5000	6400
Rated making capacity		400V, cos φ=0,45	A 5000	6300	8000

^{*(1)} Other voltages and / or utilization categories. Please consult
^{*(2)} Reference values, the associated current depends on motor manufacturer
^{*(3)} Without limiting protective device (short-circuit maintained 50... 100 ms).
^{*(4)} With limiting protective device which set a limit to peak value short-circuit making capacity and maximum power dissipation to indicated values
^{*(5)} Please consult us for more operations

			500	630	800
Short - circuit behaviour					
Rated short-circuit making capacity ^{*(3)}	I _{cm}	kA (peak)	26	26	26
Rated short-time withstand current (1sec)	I _{cw}	kA rms	16	16	16
Conditional short - circuit current ^{*(4)}		kA rms	100	100	100
Maximum cut - off current		kA (peak)	39	39	39
Maximum power dissipation		A ² s (x10 ³)	1000	1000	1000
Minimum number of mechanical operations ^{*(5)}		Cycles	10000	10000	10000
Maximum weight 2P		kg	3,91	3,91	3,91
Maximum weight 3P		kg	4,76	4,76	4,76
Maximum weight 3P+N		kg	5,70	5,70	5,70

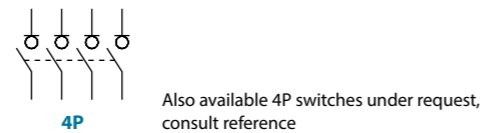

tests:



Accessories

- Direct handle**
CODE DS-LI21
- Panel handle** included shaft ^{*(e1)}
IP65|UL50E/NEMA 250
Types: 1, 3R, 4, 4X y 12
CODE DS-LA21
- Panel handle** without shaft
IP65|UL50E/NEMA 250
Types: 1, 3R, 4, 4X y 12
CODE DS-LA24
- Emergency panel handle** included shaft ^{*(e1)}
IP65|UL50E/NEMA 250
Types: 1, 3R, 4, 4X y 12
CODE DS-LR21

- Shafts**
- Standard shaft** included ^{*(e1)}
L (mm) | P (mm) |
195 | 134... 240
- Shaft extensions**
- Type 1
L (mm) | P (mm) | CODE
345 | 134... 400 | DS-EP23
- Type 2
L (mm) | P (mm) | CODE
535 | 134... 560 | DS-EP24

- Auxiliary contacts**
- 1NO+1NC CODE D5LAU01
- 2NO+2NC CODE D5LAU02
- I_e = 16 A (resistive loads)
4 A (inductive loads) at 250 Vac.

- Terminal shrouds**
- CODE DR-CU21 (1 unit)
- CODE DR-CU22 (1 unit)
- CODE DR-CU23 (1 unit)

- Phase barriers**
- CODE DR-SF21 (1 unit)
- CODE DR-SF22 (2 units)
- CODE DR-SF23 (3 units)

- Spacers**
- CODE DR-EL21 (4 units)

- Safety key lock device**
- Simple CODE DS-CB21
- Double CODE DS-CF21
- For external handle, lock the handle by means of a key in position "OFF" (under request, in "ON"), the key can only be removed with the handle locked

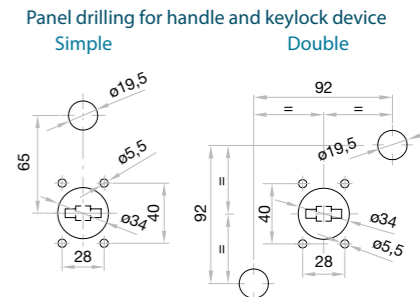

Dimensions (mm)

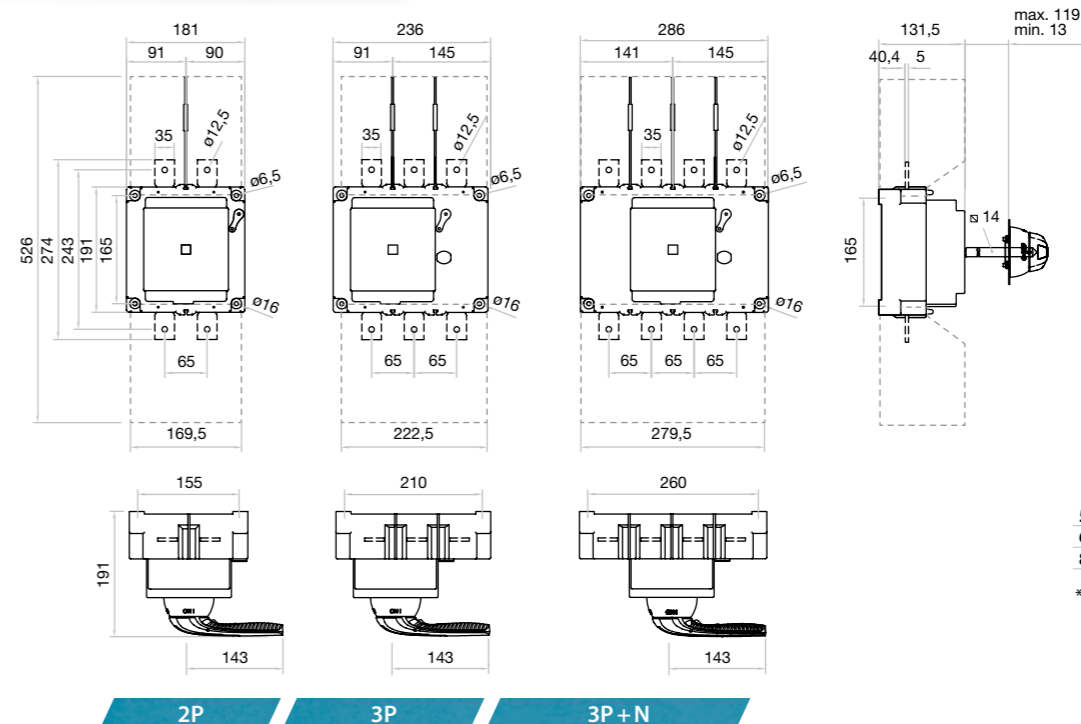

	S max (Cu) mm ²	H max (Cu) mm	L max (Cu) mm	T M	M Nxm
500 A	2x150	6	40	M10	24
630 A	2x185	2x5	40	M10	24
800 A	2x240	2x5	50 ^{*(6)}	M10	24

^{*(6)} Using phase barriers DR-SF__ to maintain the required clearance.



CIS25 - A - C - D - F

Enclosed switch - disconnecter

IP65 (with or without fuse holders) 3P - 3P+N

Size 00
A 40|63|80

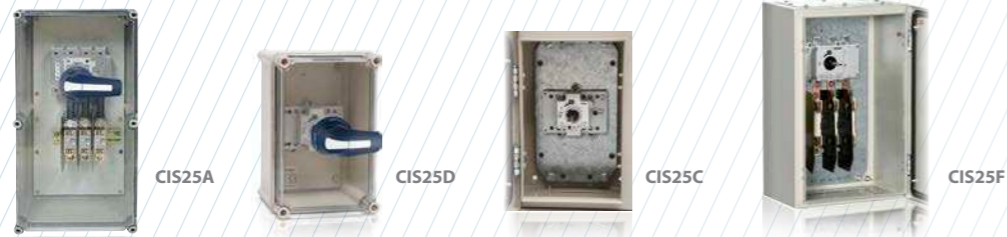

Enclosure	Model	3P	3P+N	40	63	80
polyester enclosure + fuse holders	CIS25A	CIS25A00403PB	CIS25A00633PB	CIS25A00803PB		
		CIS25A00403NB	CIS25A00633NB	CIS25A00803NB		
polyester enclosure	CIS25D	CIS25D00403PB	CIS25D00633PB	CIS25D00803PB		
		CIS25D00403NB	CIS25D00633NB	CIS25D00803NB		
metal enclosure	CIS25C	CIS25C00403PB	CIS25C00633PB	CIS25C00803PB		
		CIS25C00403NB	CIS25C00633NB	CIS25C00803NB		
metal enclosure + fuse holders	CIS25F	CIS25F00403PB	CIS25F00633PB	CIS25F00803PB		
		CIS25F00403NB	CIS25F00633NB	CIS25F00803NB		

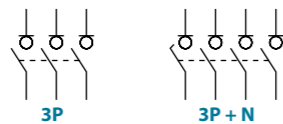

Technical information



According to IEC/EN 60947-3
IEC/EN 61439-1

			40	63	80
Rated thermal current in ambient at	I _{the}	40 °C	A 50	63	80
Rated insulation voltage	U _i	V	800	800	800
Rated dielectric strength	50 Hz., 1 min.	V	3500	3500	3500
Rated impulse withstand voltage	U _{imp}	kV	8	8	8
AC rated operational current ^{*(1)} (Rated operational frequency 50/60 Hz)	I _e	U _e 400V AC21A	A 50	63	80
		U _e 400V AC22A	A 50	63	80
		U _e 400V AC23A	A 50	63	63
		U _e 500V AC21A	A 50	63	80
		U _e 500V AC22A	A 50	63	63
AC rated operational power ^{*(2)}	P _e	3x400V AC23A	kW 27,7	34,9	34,9
		400V, sen φ = 0,65	kVA 22,5	28,3	28,3
Rated capacitor power		kVA	400	504	504
Rated breaking capacity		A	500	630	630

		40	63	80
Short - circuit behaviour				
Rated short-circuit making capacity ^{*(3)}	I _{cm} kA (peak)	5	5	5
Rated short-time withstand current (1 sec.)	I _{cw} kA rms	3	3	3
Conditional short - circuit current (rms value) ^{*(4)}	kA rms	100	100	100
Maximum cut - off current (peak value)	kA (peak)	10	10	10
Maximum power dissipation (I ² t)	A ² s (x10 ³)	54,7	54,7	54,7
Mechanical features				
Minimum number of mechanical operations ^{*(5)}	Cycles	30000	30000	30000
Maximum weight 3P	Kg		Consult	
Maximum weight 3P+N	Kg		Consult	

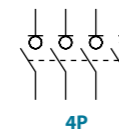

Also available 4P switches under request, consult reference

Accessories



Panel handle included
IP65



Emergency panel handle under request
IP65



Auxiliary contacts
1NO+1NC CODE D5LAU01
2NO+2NC CODE D5LAU02
I_e = 16 A (resistive loads)
4 A (inductive loads) at 250 Vac.



Safety key lock device

Simple CODE DS-CAB1
Double CODE DS-CEB1

For external handle, lock the handle by means of a key in position "OFF" (under request, in "ON"), the key can only be removed with the handle locked

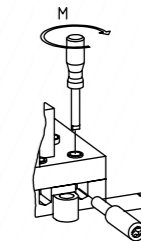

S max (Cu) mm ²	M Nxm
25	2

Dimensions (mm)

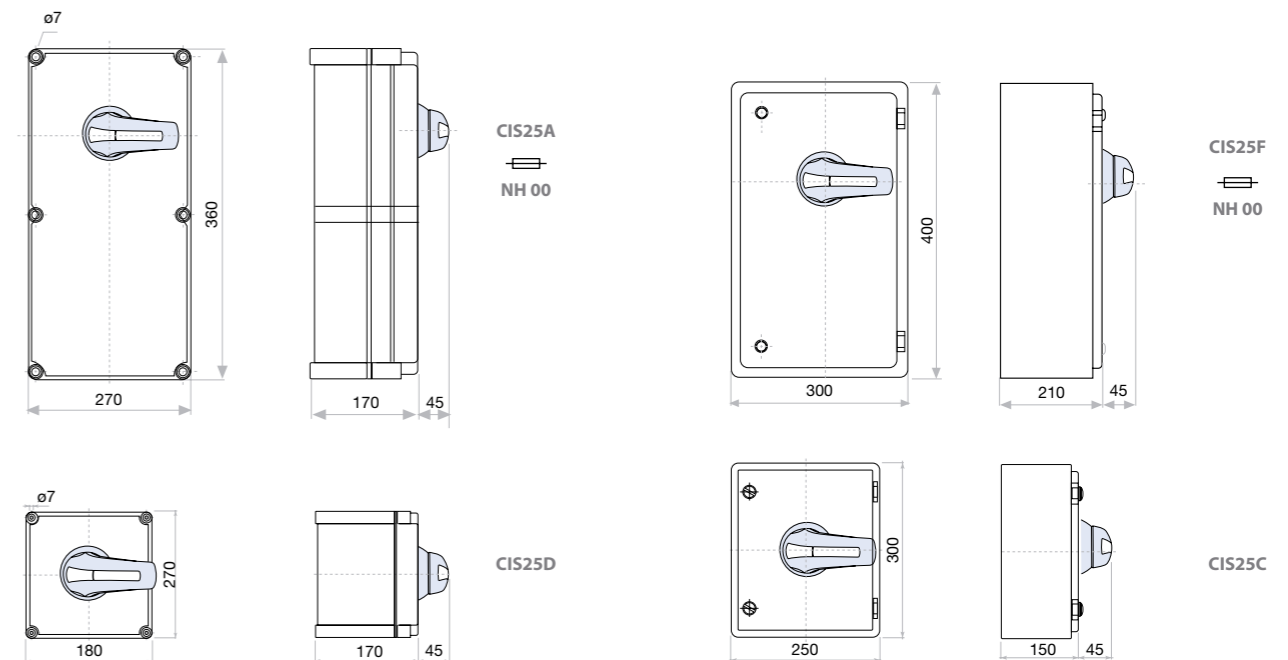

^{*(1)} Other voltages and / or utilization categories. Please consult
^{*(2)} Indicative values: current values vary from one motor manufacturer to another
^{*(3)} Without limiting protective device (short-circuit maintained 50... 100 ms.)
^{*(4)} With a protective device limiting the cut - off current and the joule integral to the indicated values
^{*(5)} Please consult us for more operations

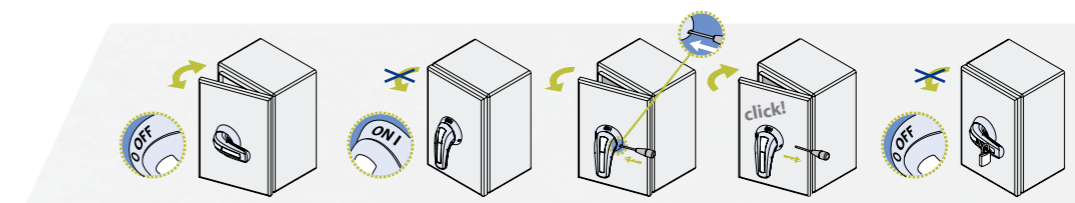

Standard supply

CIS25-A-C-D-F

Enclosed switch - disconnecter

IP65 (with or without fuse holders) 3P - 3P+N

Size 0
A 125|160

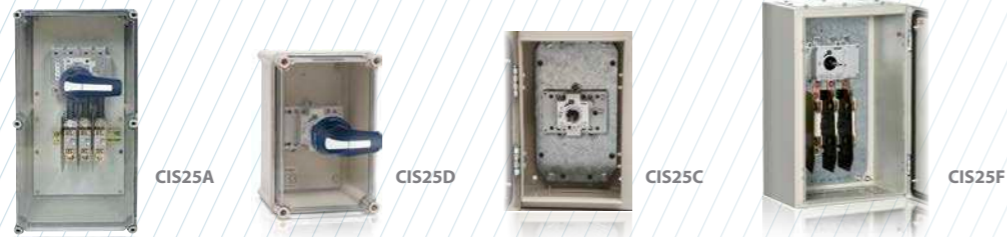

Enclosure	Model	Code	125A	160A
polyester enclosure + fuse holders	CIS25A 3P 3P+N	CIS25A01253PB		
		CIS25A01253NB		
polyester enclosure	CIS25D 3P 3P+N	CIS25D01253PB		
		CIS25D01253NB		
metal enclosure	CIS25C 3P 3P+N	CIS25C01253PB		
		CIS25C01253NB		
metal enclosure + fuse holders	CIS25F 3P 3P+N	CIS25F01253PB		
		CIS25F01253NB		

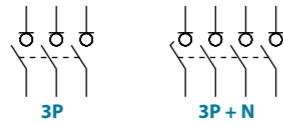

Technical information



According to IEC/EN 60947-3
IEC/EN 61439-1

		125		160	
Rated thermal current in ambient at	I_{the}	40 °C	A	125	160
Rated insulation voltage	U_i		V	1000	1000
Rated dielectric strength	50 Hz., 1 min.		V	4000	4000
Rated impulse withstand voltage	U_{imp}		kV	8	8
AC rated operational current ⁽¹⁾ I_e (Rated operational frequency 50/60 Hz)	Ue 400V AC21A	A		125	160
	Ue 400V AC22A	A		125	160
	Ue 400V AC23A	A		125	160
	Ue 500V AC21A	A		125	160
	Ue 500V AC22A	A		125	160
AC rated operational power ⁽²⁾ P_e	3x400V AC23A	kW		69,2	88,6
	400V, $\cos \phi = 0,65$	kVA		56,2	72
Rated capacitor power					
Rated breaking capacity	400V AC23A	A		1000	1280
Rated making capacity	400V AC23A	A		1250	1600

		125		160	
Short - circuit behaviour					
Rated short-circuit making capacity ⁽³⁾	I_{cm}	kA (peak)		13	13
Rated short-time withstand current (1sec.)	I_{cw}	kA rms		7	7
Conditional short - circuit current (rms value) ⁽⁴⁾		kA rms		100	100
Maximum cut - off current (peak value)		kA (peak)		17	20
Maximum power dissipation ($I^2 t$)		$A^2s (x10^3)$		55	198
Mechanical features					
Minimum number of mechanical operations ⁽⁵⁾	Cycles			30000	30000
Maximum weight 3P		Kg		Consult	
Maximum weight 3P+N		Kg		Consult	

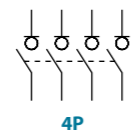

Also available 4P switches under request, consult reference

Accessories

- Panel handle** included
IP65
- Emergency panel handle** under request
IP65
- Auxiliary contacts**
1NO+1NC CODE D5LAU01
2NO+2NC CODE D5LAU02
 $I_e = 16A$ (resistive loads)
4A (inductive loads) at 250 Vac.



Safety key lock device

Simple CODE DS-CAB1
Double CODE DS-CEB1

For external handle, lock the handle by means of a key in position "OFF" (under request, in "ON"), the key can only be removed with the handle locked

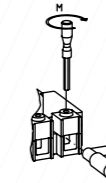

S max (Cu)	M
mm ²	Nxm
95	4

Dimensions (mm)

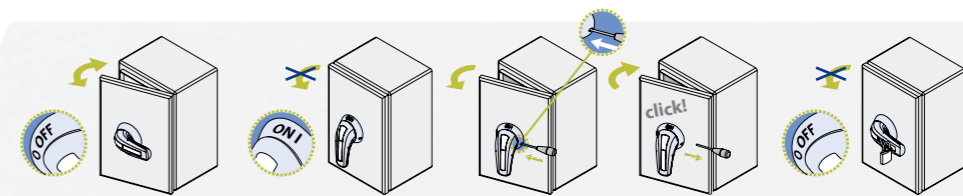
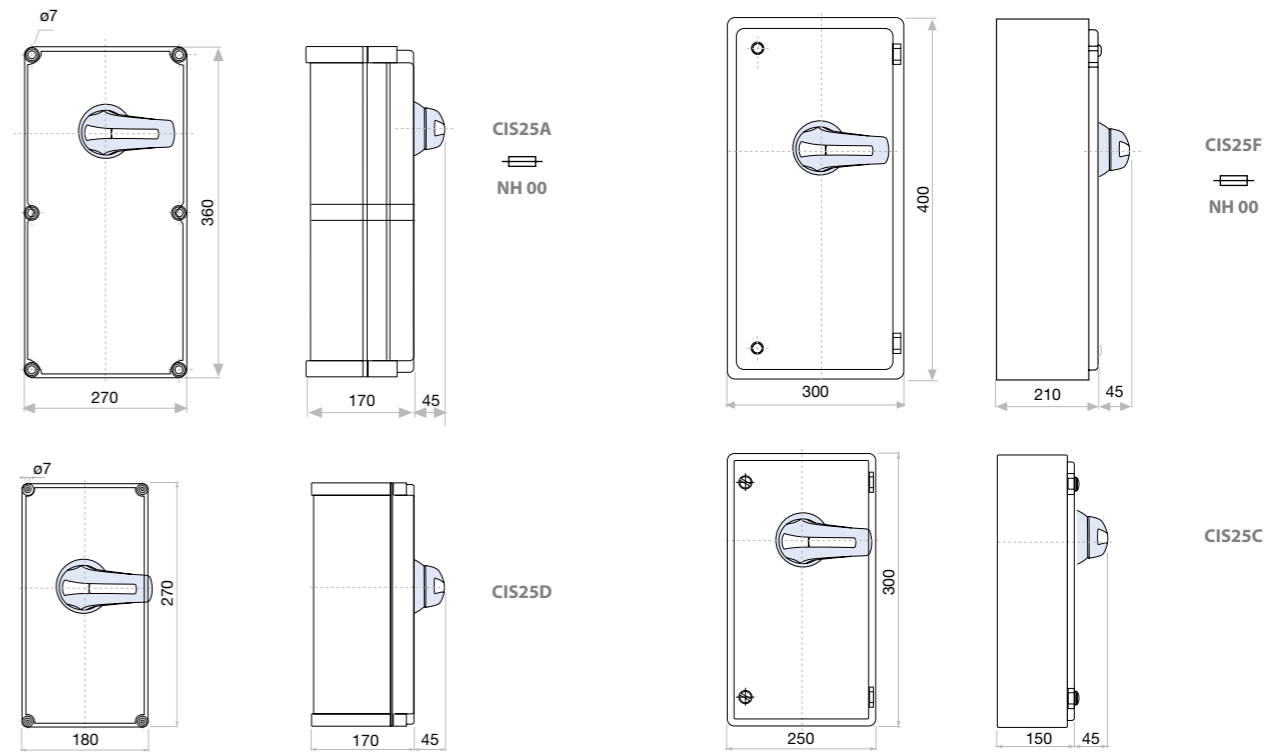

Standard supply

⁽¹⁾ Other voltages and / or utilization categories. Please consult
⁽²⁾ Indicative values: current values vary from one motor manufacturer to another
⁽³⁾ Without limiting protective device (short-circuit maintained 50... 100 ms.)
⁽⁴⁾ With a protective device limiting the cut - off current and the joule integral to the indicated values
⁽⁵⁾ Please consult us for more operations

CIS25-A-C-D-F

Enclosed switch - disconnecter

IP65 (with or without fuse holders) 3P - 3P+N

Size 1
A 200|250|315

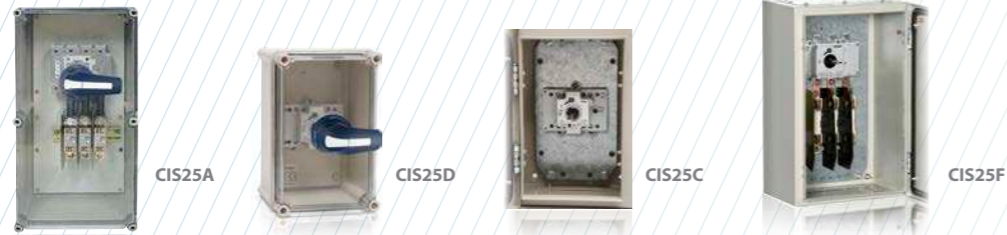

Enclosure	Model	Code	200A	250A	315A
polyester enclosure + fuse holders	CIS25A 3P	CODE-200A	CIS25A02003PR	CIS25A02503PR	CIS25A03153PR
			CIS25A02003NR	CIS25A02503NR	CIS25A03153NR
polyester enclosure	CIS25D 3P+N	CODE-250A	CIS25D02003PR	CIS25D02503PR	CIS25D03153PR
			CIS25D02003NR	CIS25D02503NR	CIS25D03153NR
metal enclosure	CIS25C 3P	CODE-315A	CIS25C02003PS	CIS25C02503PR	CIS25C03153PR
			CIS25C02003NS	CIS25C02503NR	CIS25C03153NR
metal enclosure + fuse holders	CIS25F 3P+N	CODE-315A	CIS25F02003PR	CIS25F02503PR	CIS25F03153PR
			CIS25F02003NR	CIS25F02503NR	CIS25F03153NR

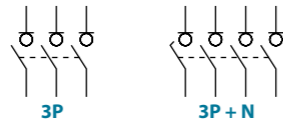

Technical information



According to IEC/EN 60947-3
IEC/EN 61439-1

		200			250			315		
Rated thermal current in ambient at	I _{the}	40 °C	A	200	250	315				
Rated insulation voltage	U _i	V		1000	1000	1000				
Rated dielectric strength	50 Hz., 1 min.	V		5000	5000	5000				
Rated impulse withstand voltage	U _{imp}	kV		8	8	8				
AC rated operational current ^{*(1)} (Rated operational frequency 50/60 Hz)	I _e	U _e 400V	AC21A	A	200	250	315			
		U _e 400V	AC22A	A	200	250	315			
		U _e 400V	AC23A	A	200	250	315			
		U _e 500V	AC21A	A	200	250	315			
		U _e 500V	AC22A	A	200	250	315			
AC rated operational power ^{*(2)}	P _e	3x400V	AC23A	kW	110,8	138,5	174,5			
		400V, sen φ = 0,65	kVAr	90	112,5	141,8				
Rated capacitor power		400V	AC23A	A	1600	2000	2520			
Rated breaking capacity		400V	AC23A	A	2000	2500	3150			

		200			250			315		
Short - circuit behaviour										
Rated short-circuit making capacity ^{*(3)}	I _{cm}	kA (peak)		20	20	20				
Rated short-time withstand current (1sec.)	I _{cw}	kA rms		12	12	12				
Conditional short - circuit current (rms value) ^{*(4)}		kA rms		100	100	100				
Maximum cut - off current (peak value)		kA (peak)		33	33	33				
Maximum power dissipation (I ² t)		A ² s (x10 ³)		497	1000	1000				
Mechanical features										
Minimum number of mechanical operations ^{*(5)}	Cycles			20000	20000	20000				
Maximum weight 3P		Kg				Consult				
Maximum weight 3P+N		Kg				Consult				

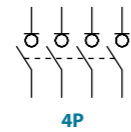

Also available 4P switches under request, consult reference

^{*(1)} Other voltages and / or utilization categories. Please consult
^{*(2)} Indicative values: current values vary from one motor manufacturer to another
^{*(3)} Without limiting protective device (short-circuit maintained 50... 100 ms.)
^{*(4)} With a protective device limiting the cut - off current and the joule integral to the indicated values
^{*(5)} Please consult us for more operations

Accessories

- Panel handle** included
IP65|UL50E/NEMA 250
Types: 1, 3R, 4, 4X y 12
- Emergency panel handle** under request
IP65|UL50E/NEMA 250
Types: 1, 3R, 4, 4X y 12
- Auxiliary contacts**
1NO+1NC CODE D5LAU01
2NO+2NC CODE D5LAU02
I_e = 16 A (resistive loads)
4 A (inductive loads) at 250 Vac.

- Terminal protection**
CODE DR-CU11
(1 kit for input or output)

- Safety key lock device**
Simple CODE DS-CA11
Double CODE DS-CE11

For external handle, lock the handle by means of a key in position "OFF" (under request, in "ON"), the key can only be removed with the handle locked

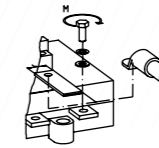

	S max (Cu) mm ²	H max (Cu) mm	L max (Cu) mm	T M	M
200 A				M8	13
250 A	185	7	25	M10	18
315 A					

Dimensions (mm)

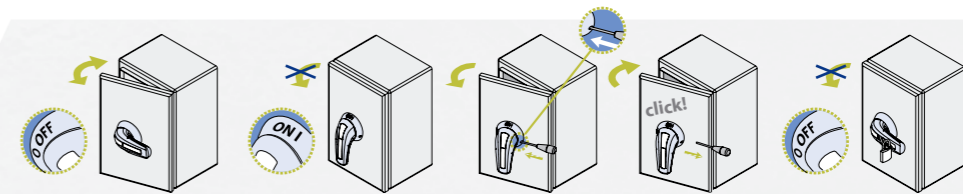
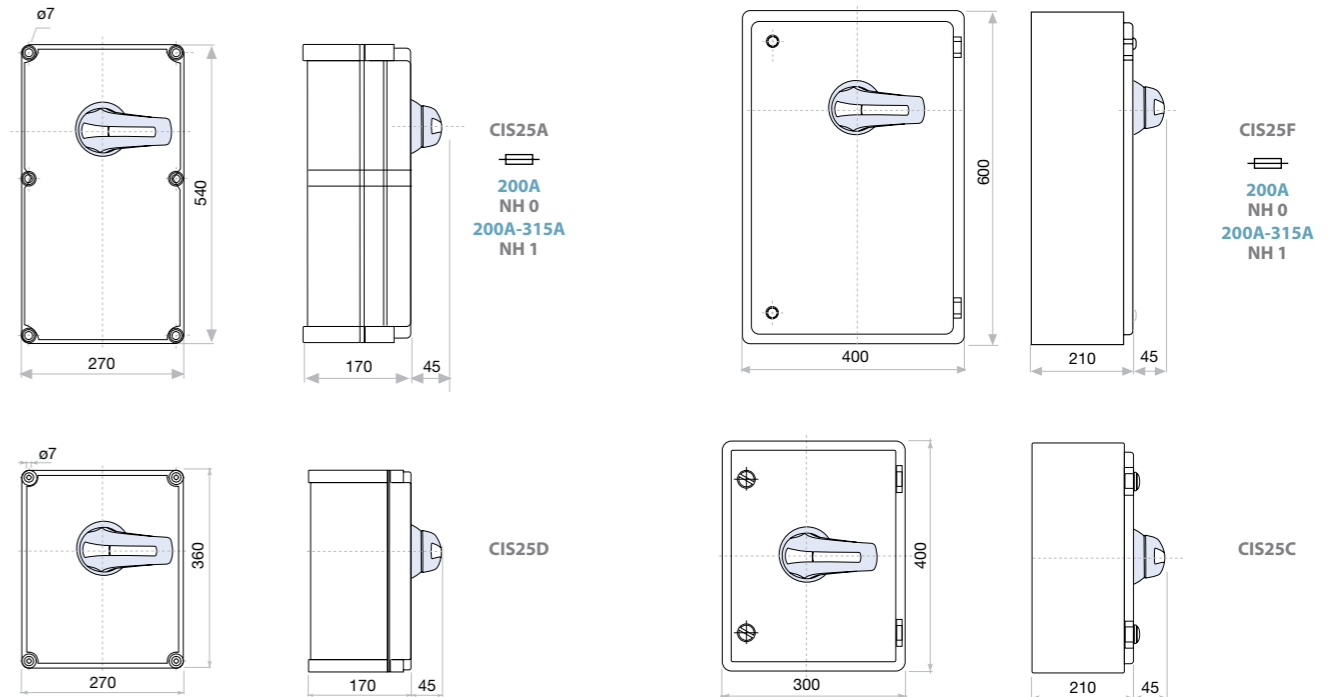

Standard supply

CIS25-A-C-D-F

Enclosed switch - disconnecter

IP65 (with or without fuse holders) 3P - 3P+N

Size 2
A 400|630

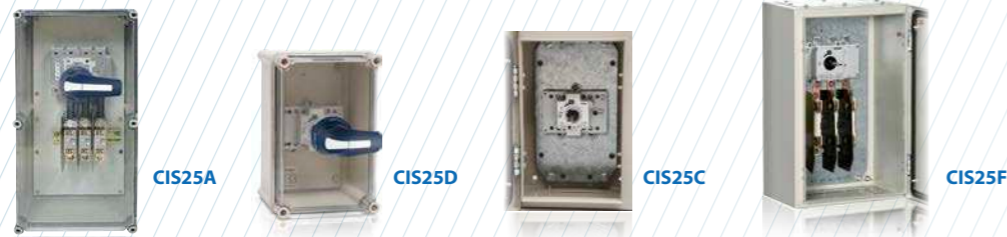

Enclosure	Model	Code	Rating
polyester enclosure + fuse holders	CIS25A 3P	CIS25A04003PR	400A
	CIS25A 3P+N	CIS25A06303PR	630A
polyester enclosure	CIS25D 3P	CIS25D04003PR	400A
	CIS25D 3P+N	CIS25D06303PR	630A
metal enclosure	CIS25C 3P	CIS25C04003PC	400A
	CIS25C 3P+N	CIS25C06303PC	630A
metal enclosure + fuse holders	CIS25F 3P	CIS25F04003PR	400A
	CIS25F 3P+N	CIS25F06303PR	630A

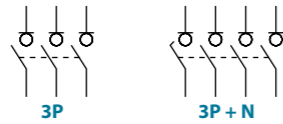

Technical information



According to IEC/EN 60947-3
IEC/EN 61439-1

		400		630	
Rated thermal current in ambient at	I _{the}	40 °C	A	400	630
Rated insulation voltage	U _i		V	1000	1000
Rated dielectric strength	50 Hz., 1 min.		V	5000	8000
Rated impulse withstand voltage	U _{imp}		kV	8	12
AC rated operational current ^{*(1)} (Rated operational frequency 50/60 Hz)	I _e	U _e 400V AC21A	A	400	630
		U _e 400V AC22A	A	400	630
		U _e 400V AC23A	A	400	630
		U _e 500V AC21A	A	400	630
AC rated operational power ^{*(2)}	P _e	3x400V AC23A	kW	221,7	349,1
		400V, sen φ = 0,65	kVAr	180,1	283,7
Rated capacitor power			kVAr	180,1	283,7
Rated breaking capacity		400V AC23A	A	3200	5000
Rated making capacity		400V AC23A	A	4000	6300

		400		630	
Short - circuit behaviour					
Rated short-circuit making capacity ^{*(3)}	I _{cm}	kA (peak)	20	26	
Rated short-time withstand current (1sec.)	I _{cw}	kA rms	12	16	
Conditional short - circuit current (rms value) ^{*(4)}		kA rms	100	100	
Maximum cut - off current (peak value)		kA (peak)	33	39	
Maximum power dissipation (I ² t)		A ² s (x10 ³)	1000	1600	
Mechanical features					
Minimum number of mechanical operations ^{*(5)}		Cycles	20000	10000	
Maximum weight 3P		Kg	Consult		
Maximum weight 3P+N		Kg	Consult		

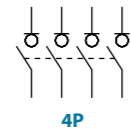

Also available 4P switches under request, consult reference

Accessories

- Panel handle** included
IP65|UL50E/NEMA 250
Types: 1, 3R, 4, 4X y 12
- Emergency panel handle** under request
IP65|UL50E/NEMA 250
Types: 1, 3R, 4, 4X y 12
- Auxiliary contacts**
1NO+1NC CODE D5LAU01
2NO+2NC CODE D5LAU02
I_e = 16 A (resistive loads)
4 A (inductive loads) at 250 Vac.

Terminal protection
CODE DR-CU21
(1 kit for input or output)

Safety key lock device
Simple CODE DS-CB21
Double CODE DS-CF21

For external handle, lock the handle by means of a key in position "OFF" (under request, in "ON"), the key can only be removed with the handle locked

	S max (Cu) mm ²	H max (Cu) mm	L max (Cu) mm	T mm	M Nxmm
400 A	2x185	6	40	M10	24
630 A	2x240	2x5	40		

Dimensions (mm)

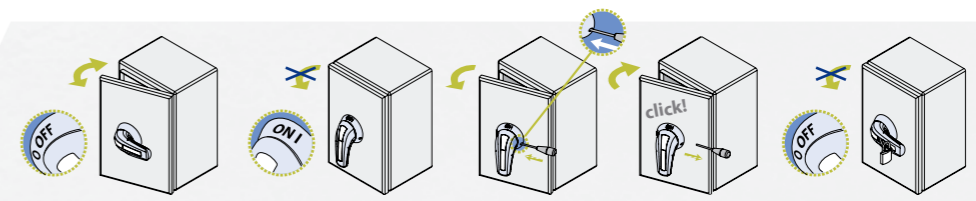
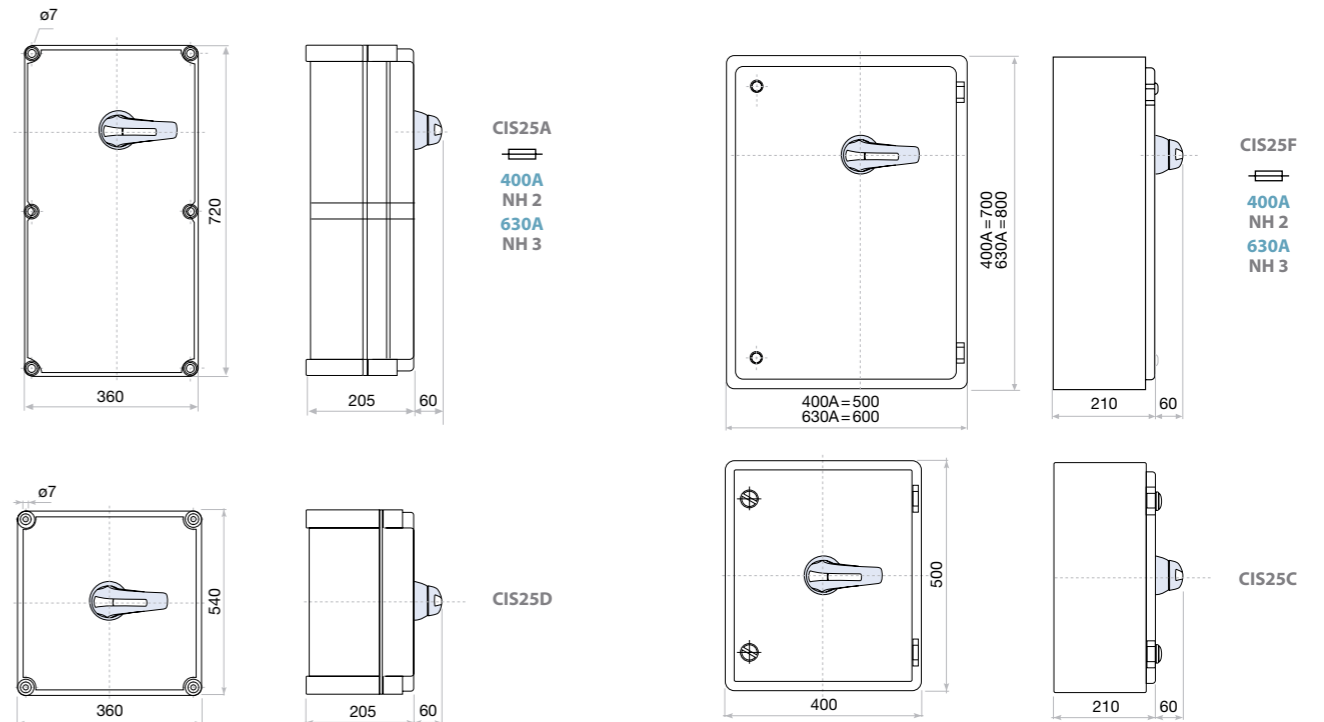

Standard supply

^{*(1)} Other voltages and / or utilization categories. Please consult
^{*(2)} Indicative values: current values vary from one motor manufacturer to another
^{*(3)} Without limiting protective device (short-circuit maintained 50... 100 ms.)
^{*(4)} With a protective device limiting the cut - off current and the joule integral to the indicated values
^{*(5)} Please consult us for more operations

CIS25-A-C-D-F

Enclosed switch - disconnecter

IP65 (with or without fuse holders) 3P - 3P+N

Size 3
A 800

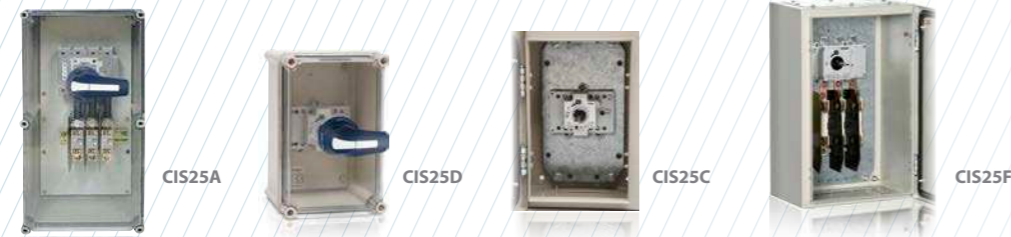

Enclosure	Model	Configuration	Code
polyester enclosure + fuse holders	CIS25A	3P 3P+N	CIS25A08003PR CIS25A08003NR
polyester enclosure	CIS25D	3P 3P+N	CIS25D08003PR CIS25D08003NR
metal enclosure	CIS25C	3P 3P+N	CIS25C08003PR CIS25C08003NR
metal enclosure + fuse holders	CIS25F	3P 3P+N	CIS25F08003PR CIS25F08003NR

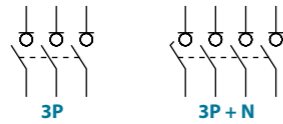

Technical information



According to IEC/EN 60947-3
IEC/EN 61439-1

		800	
Rated thermal current in ambient at	I _{the}	40 °C	A 800
Rated insulation voltage	U _i	V	1000
Rated dielectric strength	50 Hz, 1 min.	V	8000
Rated impulse withstand voltage	U _{imp}	kV	12
AC rated operational current ^{*(1)} (Rated operational frequency 50/60 Hz)	I _e	U _e 400V AC21A	A 800
		U _e 400V AC22A	A 800
		U _e 400V AC23A	A 800
		U _e 500V AC21A	A 800
		U _e 500V AC22A	A 800
AC rated operational power ^{*(2)}	P _e	3x400V AC23A	kW 443,4
		400V, sen φ = 0,65	kVA 360,2
Rated capacitor power			
Rated breaking capacity	400V AC23A	A	6400
Rated making capacity	400V AC23A	A	8000

		800	
Short - circuit behaviour			
Rated short-circuit making capacity ^{*(3)}	I _{cm}	kA (peak)	60
Rated short-time withstand current (1sec.)	I _{cw}	kA rms	25
Conditional short - circuit current (rms value) ^{*(4)}		kA rms	72
Maximum cut - off current (peak value)		kA (peak)	55
Maximum power dissipation (I ² t)		A ² s (x10 ³)	4900
Mechanical features			
Minimum number of mechanical operations ^{*(5)}	Cycles		10000
Maximum weight 3P	Kg		Consult
Maximum weight 3P+N	Kg		Consult

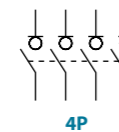

Also available 4P switches under request, consult reference

^{*(1)} Other voltages and / or utilization categories. Please consult
^{*(2)} Indicative values: current values vary from one motor manufacturer to another
^{*(3)} Without limiting protective device (short-circuit maintained 50... 100 ms.)
^{*(4)} With a protective device limiting the cut - off current and the joule integral to the indicated values
^{*(5)} Please consult us for more operations

Accessories



Panel handle included
IP65 | UL50E/NEMA 250
Types: 1, 3R, 4, 4X y 12



Emergency panel handle under request
IP65 | UL50E/NEMA 250
Types: 1, 3R, 4, 4X y 12



Auxiliary contacts
1NO+1NC CODE D5LAU01
2NO+2NC CODE D5LAU02
I_e = 16 A (resistive loads)
4 A (inductive loads) at 250 Vac.



Terminal protection
CODE DR-CU31
(1 kit for input or output)



Safety key lock device
Simple CODE DS-CB31
Double CODE DS-CF31

For external handle, lock the handle by means of a key in position "OFF" (under request, in "ON"), the key can only be removed with the handle locked

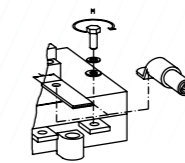

S max (Cu)	H max (Cu)	L max (Cu)	T	M
mm ²	mm	mm		Nxm
2x240	2x10	50	M14	45

Dimensions (mm)

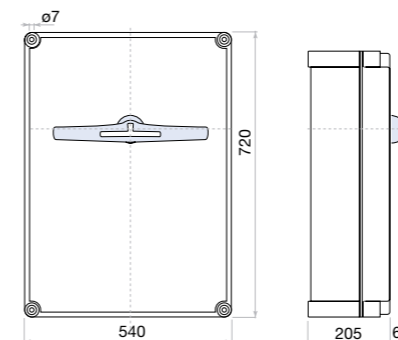
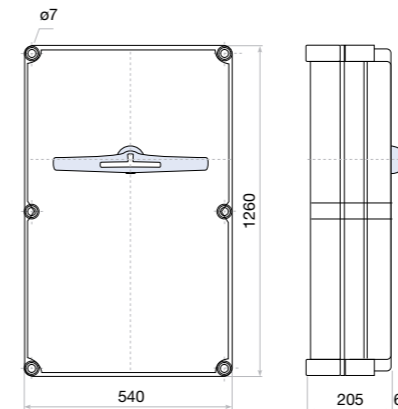

CIS25A
NH 4

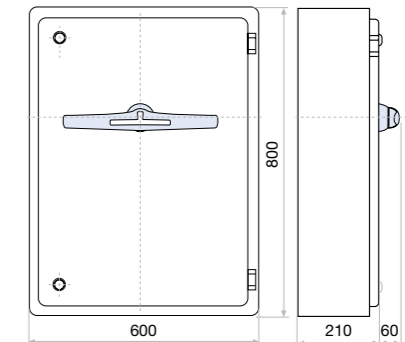

CIS25F
NH 4

CIS25D

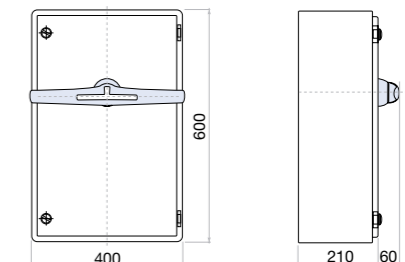

CIS25C

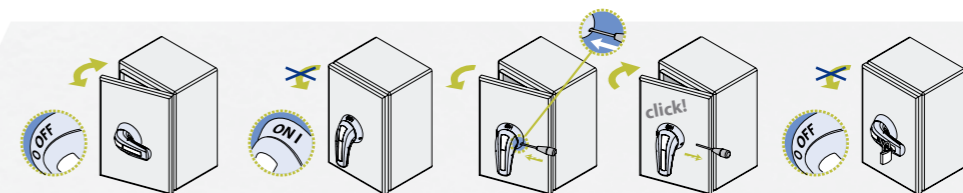

Standard supply

CIS25-A-C-D-F

Enclosed switch - disconnecter

IP65 (with or without fuse holders) 3P - 3P+N

Size 4
A 1000|1250|1600

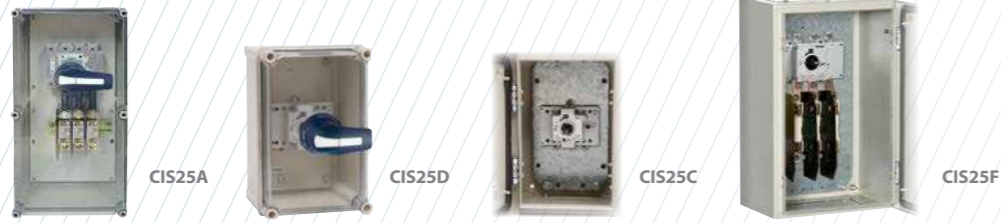

			CODE-1000A	CODE-1250A	CODE-1600A
polyester enclosure + fuse holders	CIS25A	3P	CIS25A10003PS	CIS25A12503PS	CIS25A16003PS
			CIS25A10003NS	CIS25A12503NS	CIS25A16003NS
polyester enclosure	CIS25D	3P	CIS25D10003PS	CIS25D12503PS	CIS25D16003PS
			CIS25D10003NS	CIS25D12503NS	CIS25D16003NS
metal enclosure	CIS25C	3P	CIS25C10003PS	CIS25C12503PS	CIS25C16003PS
			CIS25C10003NS	CIS25C12503NS	CIS25C16003NS
metal enclosure + fuse holders	CIS25F	3P	CIS25F10003PS	CIS25F12503PS	CIS25F16003PS
			CIS25F10003NS	CIS25F12503NS	CIS25F16003NS

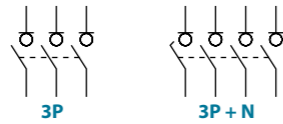

Technical information



According to IEC/EN 60947-3
IEC/EN 61439-1

			1000	1250	1600
Rated thermal current in ambient at	I_{the}	40 °C	A 1000	1250	1600
Rated insulation voltage	U_i	V	1000	1000	1000
Rated dielectric strength	50 Hz., 1 min.	V	10000	10000	10000
Rated impulse withstand voltage	U_{imp}	kV	12	12	12
AC rated operational current ⁽¹⁾ I_e (Rated operational frequency 50/60 Hz)	Ue 400V AC21A	A	1000	1250	1600
	Ue 400V AC22A	A	1000	1250	1600
	Ue 400V AC23A	A	1000	1000	1000
	Ue 500V AC21A	A	1000	1250	1600
	Ue 500V AC22A	A	1000	1000	1250
	Ue 500V AC23A	A	800	800	900

				1000	1250	1600
AC rated operational power ⁽²⁾	P_e	3x400V AC23A	kW	554,2	554,2	554,2
Rated capacitor power	400V, sen $\varphi = 0,65$	kVAr		450,3	450,3	450,3
Rated breaking capacity	400V	AC23A	A	8000	8000	8000
Rated making capacity	400V	AC23A	A	10000	10000	10000
Short - circuit behaviour						
Rated short-circuit making capacity ⁽³⁾	I_{cm}	kA (peak)		60	60	75
Rated short-time withstand current (1sec.)	I_{cw}	kA rms		25	25	50
Mechanical features						
Minimum number of mechanical operations ⁽⁴⁾		Cycles		10000	10000	4500
Maximum weight 3P		Kg		Consult		
Maximum weight 3P+N		Kg		Consult		

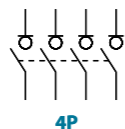

Also available 4P switches under request, consult reference

Accessories



Panel handle included
IP65 | UL50E/NEMA 250
Types: 1, 3R, 4, 4X y 12



Emergency panel handle under request
IP65 | UL50E/NEMA 250
Types: 1, 3R, 4, 4X y 12



Auxiliary contacts
1NO+1NC CODE D5LAU01
2NO+2NC CODE D5LAU02
 $I_e = 16$ A (resistive loads)
4 A (inductive loads) at 250 Vac.



Terminal protection
CODE DR-CU41
(1 kit for input or output)



Safety key lock device
Simple CODE DS-CB41
Double CODE DS-CF41

For external handle, lock the handle by means of a key in position "OFF" (under request, in "ON"), the key can only be removed with the handle locked

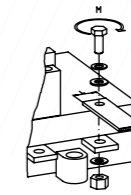

	H max (Cu)	L max (Cu)	M
1000 A	mm	mm	Nxm
1250 A	2x7	80	M16
1600 A			M14

Dimensions (mm)

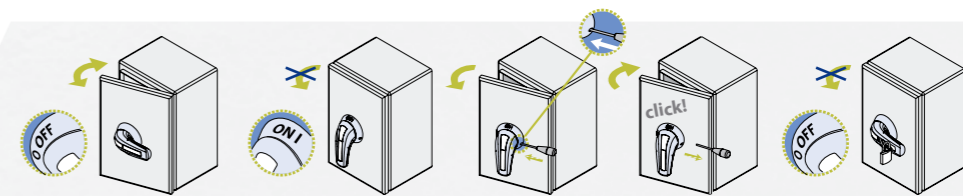
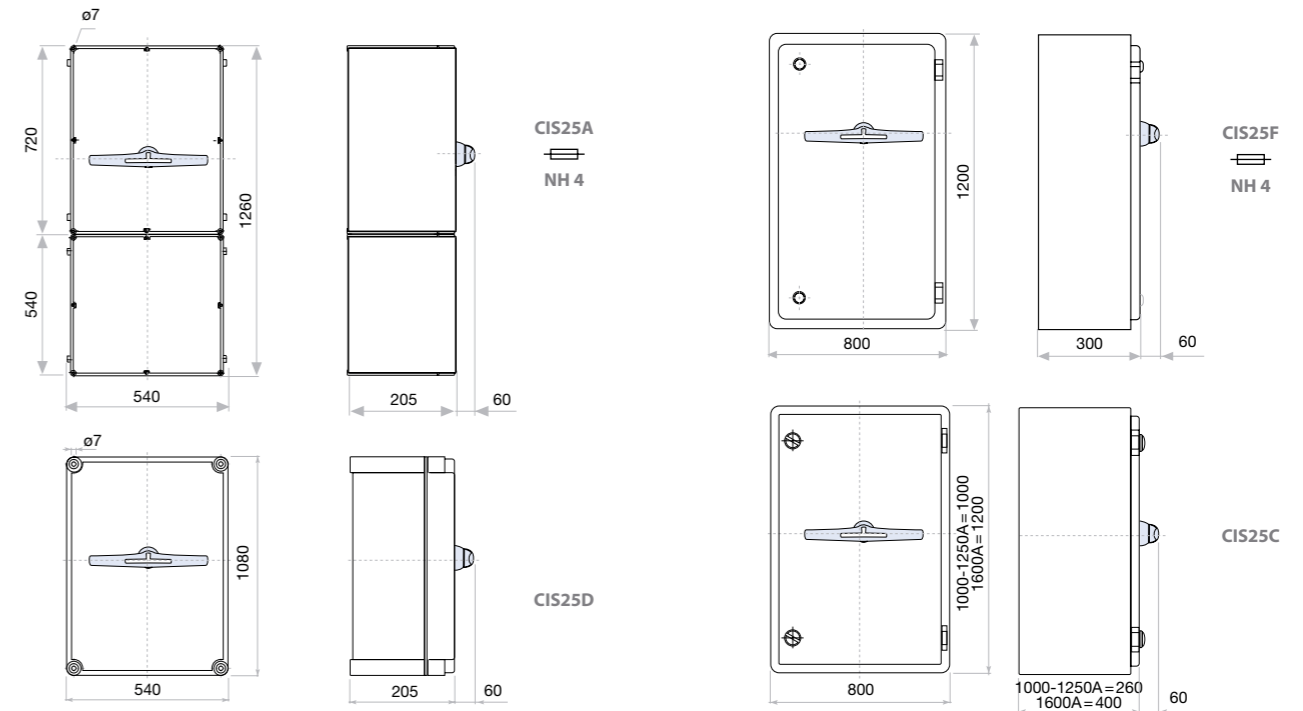

Standard supply

IPTA | IPTR | IPTU

Switch disconnecter for transformer secondary protection

A 40...630

4P - 3P+N

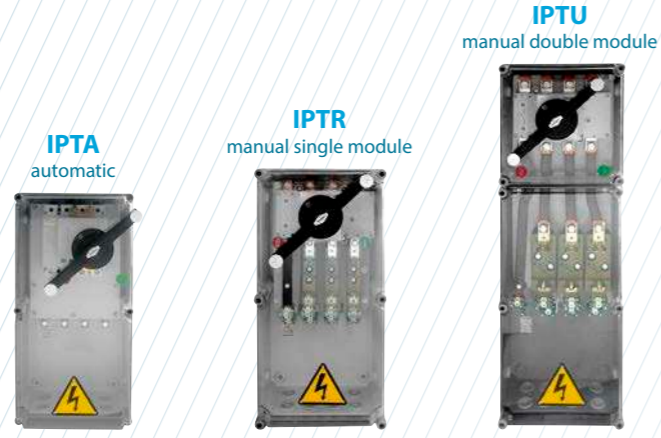

Dimensions (mm)

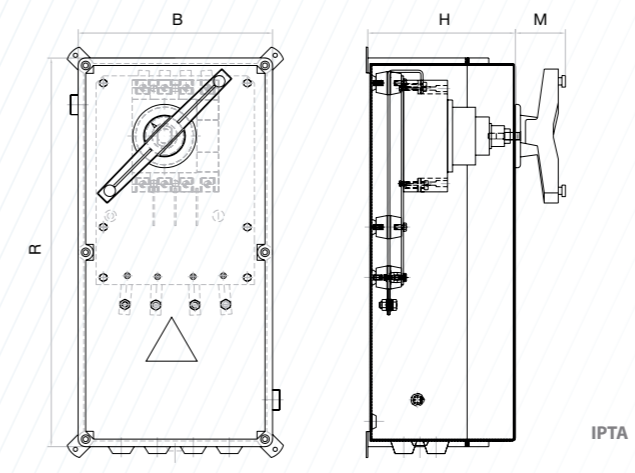

	R	B	H	M
40 - 63 - 80 - 100 A 160 - 200 - 250 A	540	270	205	69,5
400 A	540	360	263	69,5
630 A	720	360	205	69,5

Series	Code	Code	Code	Code
IPTA 4P	CODE-40A IPTA00404PS0	CODE-50...63A IPTA00634PS0	CODE-80...100A IPTA01004PS0	CODE-125...160A IPTA01604PS0
	CODE-200A IPTA02004PS0	CODE-250A IPTA02504PS0	CODE-320...400A IPTA04004PS0	CODE-630A IPTA06304PT0
IPTR 3P+N	CODE-160A IPTR01603NB0	CODE-250A IPTR02503NB0	CODE-400A IPTR04003NB0	CODE-630A IPTR06303NT0
	CODE-160A IPTU01603NB0	CODE-250A IPTU02503NB0	CODE-400A IPTU04003NB0	CODE-630A IPTU06303NT0

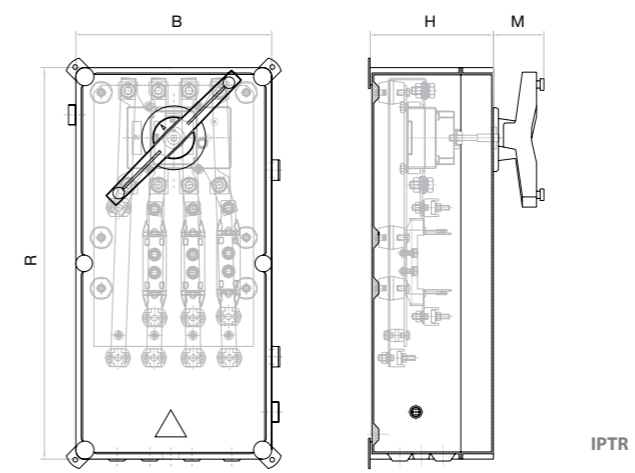
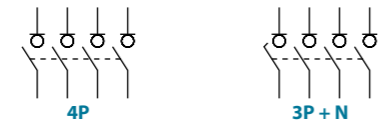

	R	B	H	M
160 - 250 A	540	270	170	69,5
400 A	720	360	205	69,5
630 A	720	360	205	69,5

Technical information



According to IEC / EN 60947-3
IEC / EN 61439-1

	Amps (Ith)	NH / DIN
IPTR	160	0
	250	1
	400	2
	630	3
IPTU	160	0
	250	1
	400	2
	630	3

Selection table		
kVA	UF/UL (Vac)	In (A)
50	380 / 220	100
75	380 / 220	125
100	380 / 220	160
125	380 / 220	200
160	380 / 220	250
250	380 / 220	400
400	380 / 220	630

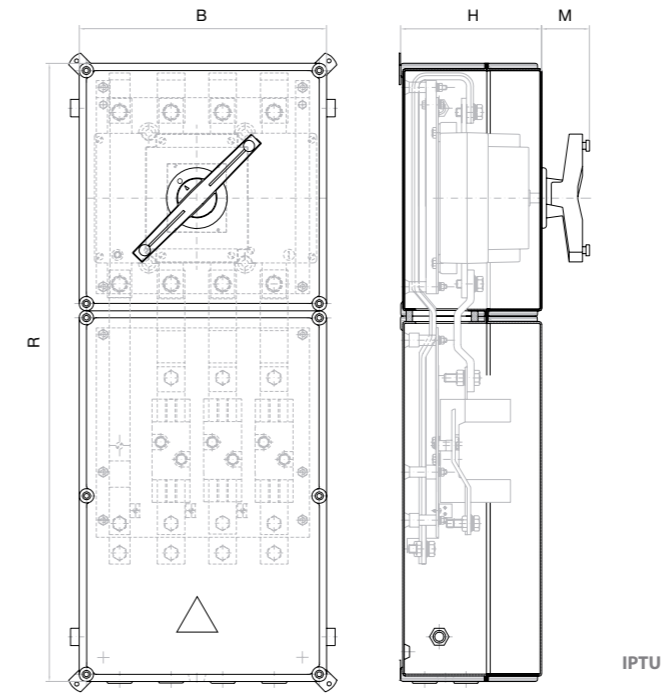

	R	B	H	M
160 - 250 A	810	270	170	69,5
400 A	810	360	205	69,5
630 A	900	360	205	69,5

AC Fusible switches

Fusible switches with high operating load capacity and a high level disconnection insulation; high reliability and safety in abnormal situations, available in two construction models, with a wide range of currents, fusible types and various accessories.

series
M11

series
M21

According to:
IEC/EN 60947-3
IEC/EN 61439-1
RoHs



Testing and approvals:



The fusible switches in its two series, are manufactured with high safety self-extinguishing materials, providing an excellent level of electrical insulation, low smoke emission and high resistance to electro-mechanical stress.

They combine in a compact unit the function of a switch - disconnecter with the protection against overloads and short - circuits given by the fuses, these once installed remain fixed in the switch, ensuring a long electrical and mechanical life and safe operations for the user.

They comply with environmental requirements and undergo strict quality controls for a reliable product that meets the most demanding requirements.

The M21 series consist of a sandwich-type body containing self-cleaning blade type contacts, with pre-arc zones to ensure long term, fault-free energy transmission and coated with silver alloy for long electromechanical life, externally has housings to insert fuses according to the appropriate format. The jump mechanism provides quick and independent switching due to the accumulation of elastic potential energy, which is transmitted at high speed to the contacts for arc extinction.

The M11 series is of modular construction, with the contacts being moved by a cross shaft with tripping being positive opening.

Functional and ergonomic handle

- > Good grip and excellent torque/resistance
- > Padlockable handle in **OFF** position (up to three locks Ø 5-8 mm)
- > Door interlock in **ON** position
- > Door interlock in **OFF** position, with lock on
- > Release feature in **ON** position (with the use of a tool for maintenance operations). The handle internal lock is automatically restored
- > Self-centering shaft for door handle



Neutral pole advanced during closing and withdrawn while opening

A safety system preventing accidental overvoltage during switching in receptors powered between phase and neutral.

Due to the design in our 3P+N switch - disconnectors and changeover switches, the neutral contact closes before the main phases and opens later, thus ensuring this operation mode.

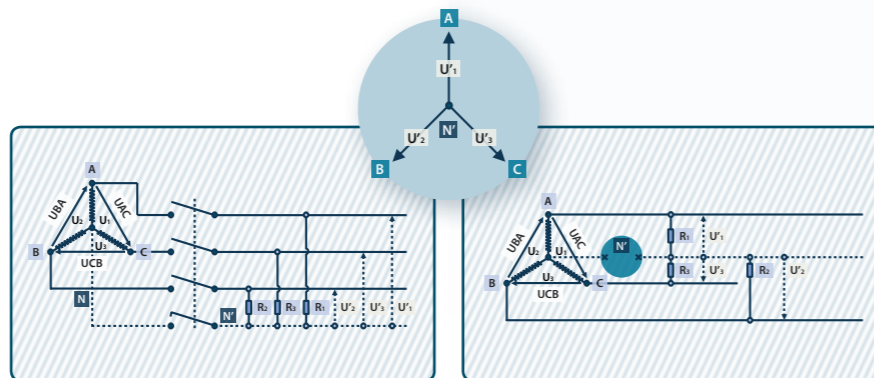

Range coding:

The M11/M21 series, are identified by a code that describes their most important characteristics as described below

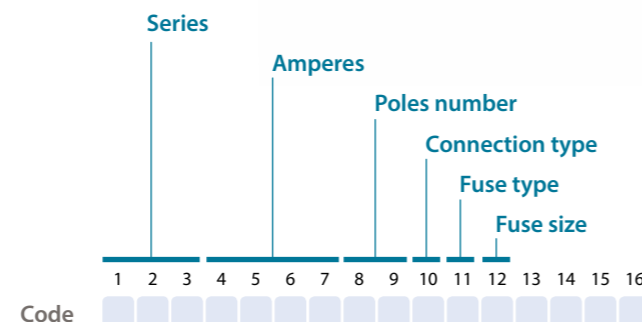

series M11



1 2 3 4 5 6
M 1 1

Modular concept.
Fuse-links cylindrical, NH/DIN,BS.
Fuse cover interlock in the ON position.
Different handles depend on the installation mode.

series M21



1 2 3 4 5 6
M 2 1

Compact model.
Fuse-links NH/DIN,BS.
Fuse cover interlock in the ON position.
Different handles depend on the installation mode.

series CIF21



IP65

1 2 3 4 5 6 7
CIF21C

M11 metal enclosed fusible switch.
External padlockable handle with locking door in ON position.
Removing door blocked by padlock when handle is in OFF position.

series CIF22



IP65

1 2 3 4 5 6 7
CIF22C

M21 metal enclosed fusible switch.
External padlockable handle with locking door in ON position.
Removing door blocked by padlock when handle is in OFF position.

M11 Fusible switch base mounting 2P - 3P - 3P+N

Size 00

A 32|50|63|100

NFC 14x51 NH 00C
BS A1-A2-A3



	CODE-50A	CODE-63A	CODE-100A
2P	M1100502PBC20	M1100632PBDB0	M1101002PBDB0
3P	M1100503PBC20	M1100633PBDB0	M1101003PBDB0
3P+N	M1100503NBC20	M1100633NBDB0	M1101003NBDB0

Fuses NFC 14x51 NH 00C NH 00C

	CODE-32A	CODE-63A
2P	M1100322PBBA0	M1100632PBDB0
3P	M1100323PBBA0	M1100633PBDB0
3P+N	M1100323NBBA0	M1100633NBDB0

Fuses BS A1 BS A2-BS A3*(6)

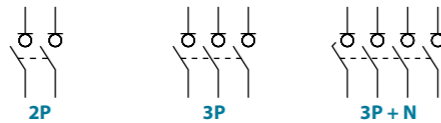

Technical information



According to IEC/EN 60947-3

			32	50	63	100	
Fuses	NH/DIN		-	-	00C	00C	
	BS	A1	-	A2-A3*(6)	-	-	
	NFC	-	14x51	-	-	-	
Rated thermal current in ambient at 40 °C	I _{th}	A	32	50	63	100	
Rated thermal current in enclosure	I _{the}	A	-	-	63	100	
Rated insulation voltage	U _i	V	800	800	800	800	
Rated dielectric strength	50 Hz, 1 min	V	5000	5000	5000	5000	
Rated impulse withstand voltage	U _{imp}	kV	8	8	8	8	
Power dissipation in fuse links *(1)	NH/DIN	W	-	-	5,1	6,9	
	BS		2,8	-	6,6	-	
AC rated operational current *(2)	I _e	400 V AC21A	A	32	50	63	100
		400 V AC22A	A	32	50	63	100
		400 V AC23A	A	32	50	63	100
		500 V AC21A	A	32	50	63	100
		500 V AC22A	A	32	50	63	100
AC rated operational power *(3)	P _e	400 V AC23A	kW	15	25	30	55

*(1) Power dissipation values of fuse - links used in type tests. Please consult for fuse - links with higher power dissipation
*(2) Other voltages and / or utilization categories. Please consult
*(3) Indicative values: current values depend on the motor manufacturer

			32	50	63	100
Rated capacitor power	400 V	kVA _r	15	18	25	42
Rated breaking capacity	400 V; cos φ = 0,35÷0,45	A	260	400	504	800
Rated making capacity	400 V; cos φ = 0,45	A	320	500	800	1000
Short - circuit behaviour						
Short - time withstand current *(4)	kA rms		100	100	100	100
Short - circuit making current *(4)	kA rms		50	50	50	50
Maximum cut - off current	kA (peak)		13	13	13	13
Maximum power dissipation	A ² s (x 10 ³)		76	76	76	76
Minimum number of mechanical operation *(5)	Cycles		10000	10000	10000	10000
Maximum weight 2P	kg		0,7	0,7	0,7	0,7
Maximum weight 3P	kg		1,1	1,1	1,1	1,1
Maximum weight 3P+N	kg		1,5	1,5	1,5	1,5

*(4) With a protective device limiting the cut - off current and the joule integral to the indicated values
*(5) Please consult us for more operations
*(6) Only fuses with diameter < 25 mm

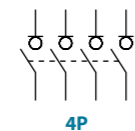

Also available 4P switches under request, consult reference

Accessories

- Frontal panel handle** included shaft *(e1)
 IP65
 CODE DS-SA02
- Emergency frontal panel handle** included shaft *(e1)
 IP65
 CODE DS-SR02
- Direct handle**
 Frontal CODE DM1SI01
 Side CODE DM1SYB1
- Side handle** included shaft *(e1)
 IP65
 CODE DM1SLB1
 CODE DM1SAB1 BS
- Emergency side handle** included shaft *(e1)
 IP65
 CODE DM1RLB1
 CODE DM1SRB1 BS

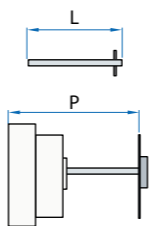

Shafts

- Standard shaft** included *(e1)
 L (mm) | P (mm)
 250 | 144... 270
- Extended shafts**
 Frontal panel handle
 L (mm) | P (mm) | CODE
 387 | 144... 407 | DS-EP05
- Side handle
 L (mm) | P (mm) | CODE
 347 | 144... 367 | DS-EP02

Dimensions (mm)

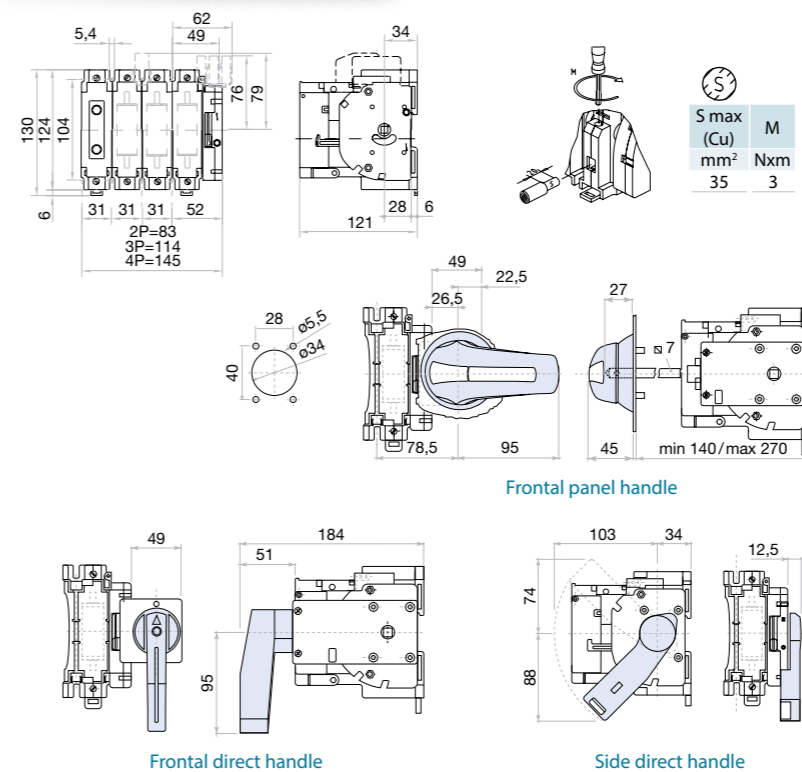

- Terminal shrouds** (1 kit for input or output)
 2 UNITS | 3 UNITS
 DM1CU01 | DM1CU02

Auxiliary contacts

- 1NO+1NC CODE DM1AUB1
 2NO+2NC CODE DM1AUB2
 I_e = 16 A (resistive loads)
 4 A (inductive loads) at 250 Vac.

Safety key lock device

- Simple CODE DS-CAB1
 Double CODE DS-CEB1

For external handle, lock the handle by means of a key in position "OFF" (under request, in "ON"), the key can only be removed with the handle locked

Panel drilling for handle and keylock device
 Simple | Double

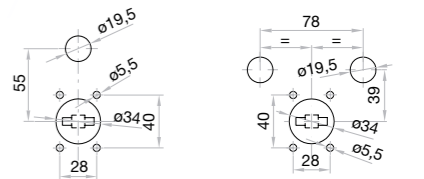

Fuses

Maximum dimensions

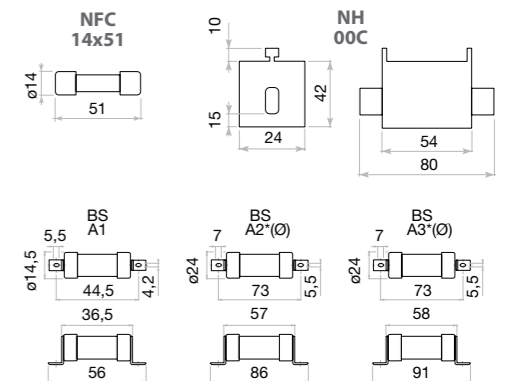

*(0) Only fuses with diameter < 25 mm

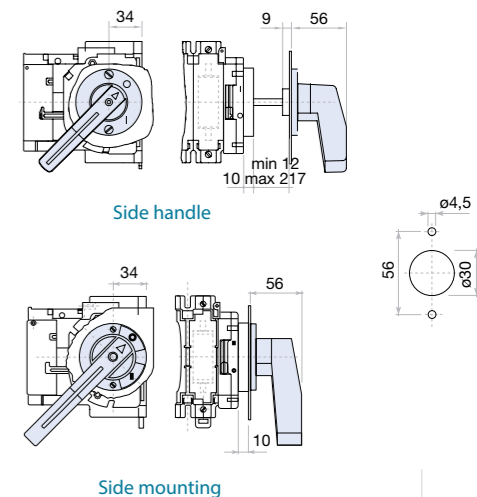

M11 Fusible switch base mounting 2P - 3P - 3P+N

Size 0
A 100|125|160
 NFC 22x58 NH 00
 BS A2-A3

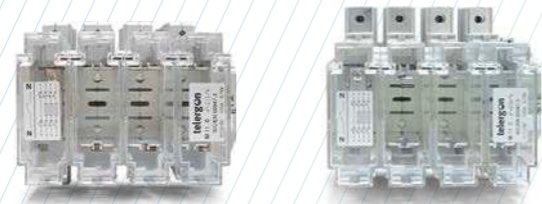

	CODE-125A	CODE-125A	CODE-125A	CODE-125A	CODE-160A	CODE-160A
2P	M1101252PBC30	M1101252PTC30	M1101252PBDB0	M1101252PTDB0	M1101602PBDB0	M1101602PTDB0
3P	M1101253PBC30	M1101253PTC30	M1101253PBDB0	M1101253PTDB0	M1101603PBDB0	M1101603PTDB0
3P+N	M1101253NBC30	M1101253NTC30	M1101253NBDB0	M1101253NTDB0	M1101603NBDB0	M1101603NTDB0

Fuses NFC 22x58 NFC 22x58 NH 00 NH 00 NH 00 NH 00

	CODE-100A	CODE-100A
2P	M1101002PBB00	M1101002PTB00
3P	M1101003PBB00	M1101003PTB00
3P+N	M1101003NBB00	M1101003NTB00

Fuses BS A2-BS A3 BS A2-BS A3

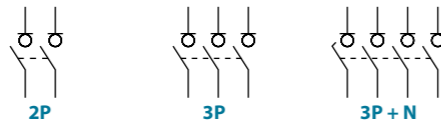

Technical information



According to IEC/EN 60947-3

Fuses	NH/DIN	-	100	125	160	
			00	00	00	
	BS	A2-A3	-	-	-	
	NFC	-	22x58	-	-	
Rated thermal current in ambient at 40 °C	Ith	A	100	125	160	
Rated thermal current in enclosure	Ithe	A	-	125	160	
Rated insulation voltage	Ui	V	800	800	800	
Rated dielectric strength	50 Hz, 1 min	V	6000	6000	6000	
Rated impulse withstand voltage	Uimp	kV	8	8	8	
Power dissipation in fuse links ⁽¹⁾	NH/DIN	W	-	9,5	11,8	
	BS		8,5	-	-	
	NFC		-	12,5	-	
AC rated operational current ⁽²⁾	le	400 V AC21A	A	100	125	160
		400 V AC22A	A	100	125	160
		400 V AC23A	A	100	125	160
		500 V AC21A	A	100	125	160
		500 V AC22A	A	100	125	160
		500 V AC23A	A	100	125	125
AC rated operational power ⁽³⁾	Pe	400 V AC23A	kW	55	65	90

⁽¹⁾ Power dissipation values of fuse - links used in type tests. Please consult for fuse - links with higher power dissipation

⁽²⁾ Other voltages and / or utilization categories. Please consult

⁽³⁾ Indicative values: current values depend on the motor manufacturer

		100	125	160	
Rated capacitor power	400 V	kVar	42	52	60
Rated breaking capacity	400 V; cos φ = 0,35+0,45	A	800	1000	1280
Rated making capacity	400 V; cos φ = 0,45	A	1000	1250	1600
Short - circuit behaviour					
Short - time withstand current ⁽⁴⁾	kA rms	100	100	100	
Short - circuit making current ⁽⁴⁾	kA rms	50	50	50	
Maximum cut - off current	kA (peak)	17	17	17	
Maximum power dissipation	A ² s (x 10 ³)	190	190	190	
Minimum number of mechanical operations ⁽⁵⁾	Cycles	10000	10000	10000	
Maximum weight 2P	kg	1,2	1,2	1,2	
Maximum weight 3P	kg	1,7	1,7	1,7	
Maximum weight 3P+N	kg	2,2	2,2	2,2	

⁽⁴⁾ With a protective device limiting the cut - off current and the joule integral to the indicated values

⁽⁵⁾ Please consult us for more operations

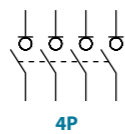

Also available 4P switches under request, consult reference

Accessories

- Frontal panel handle** included shaft ^(e1)
 IP65
 CODE DS-SA02
- Emergency frontal panel handle** included shaft ^(e1)
 IP65
 CODE DS-SR02
- Direct handle**
 Frontal CODE DM1SI01
 Side CODE DM1SYB1
- Side handle** included shaft ^(e1)
 IP65
 CODE DM1SLB1
- Emergency side handle** included shaft ^(e1)
 IP65
 CODE DM1RLB1

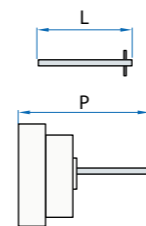

Shafts

Standard shaft included ^(e1)
 L (mm) | P (mm)
 250 | 144... 270

Extended shafts
Frontal panel handle
 L (mm) | P (mm) | CODE
 387 | 144... 407 | DS-EP05

Side handle
 L (mm) | P (mm) | CODE
 347 | 144... 367 | DS-EP02

Terminal shrouds (1 kit for input or output)
 2 UNITS | 3 UNITS
 DM1CU01 | DM1CU02

Auxiliary contacts
 1NO+1NC CODE DM1AUB1
 2NO+2NC CODE DM1AUB2
 Ie = 16 A (resistive loads)
 4 A (inductive loads) at 250 Vac.

Safety key lock device
 Simple CODE DS-CAB1
 Double CODE DS-CEB1

For external handle, lock the handle by means of a key in position "OFF" (under request, in "ON"), the key can only be removed with the handle locked

Panel drilling for handle and keylock device
 Simple | Double

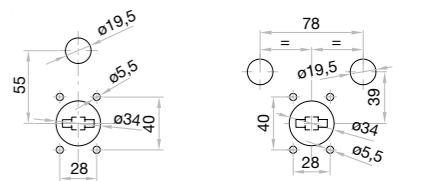

Fuses

Maximum dimensions

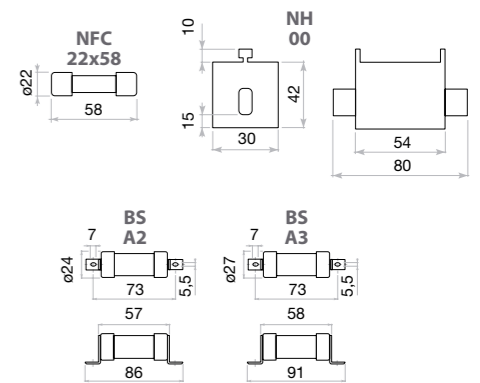

Dimensions (mm)

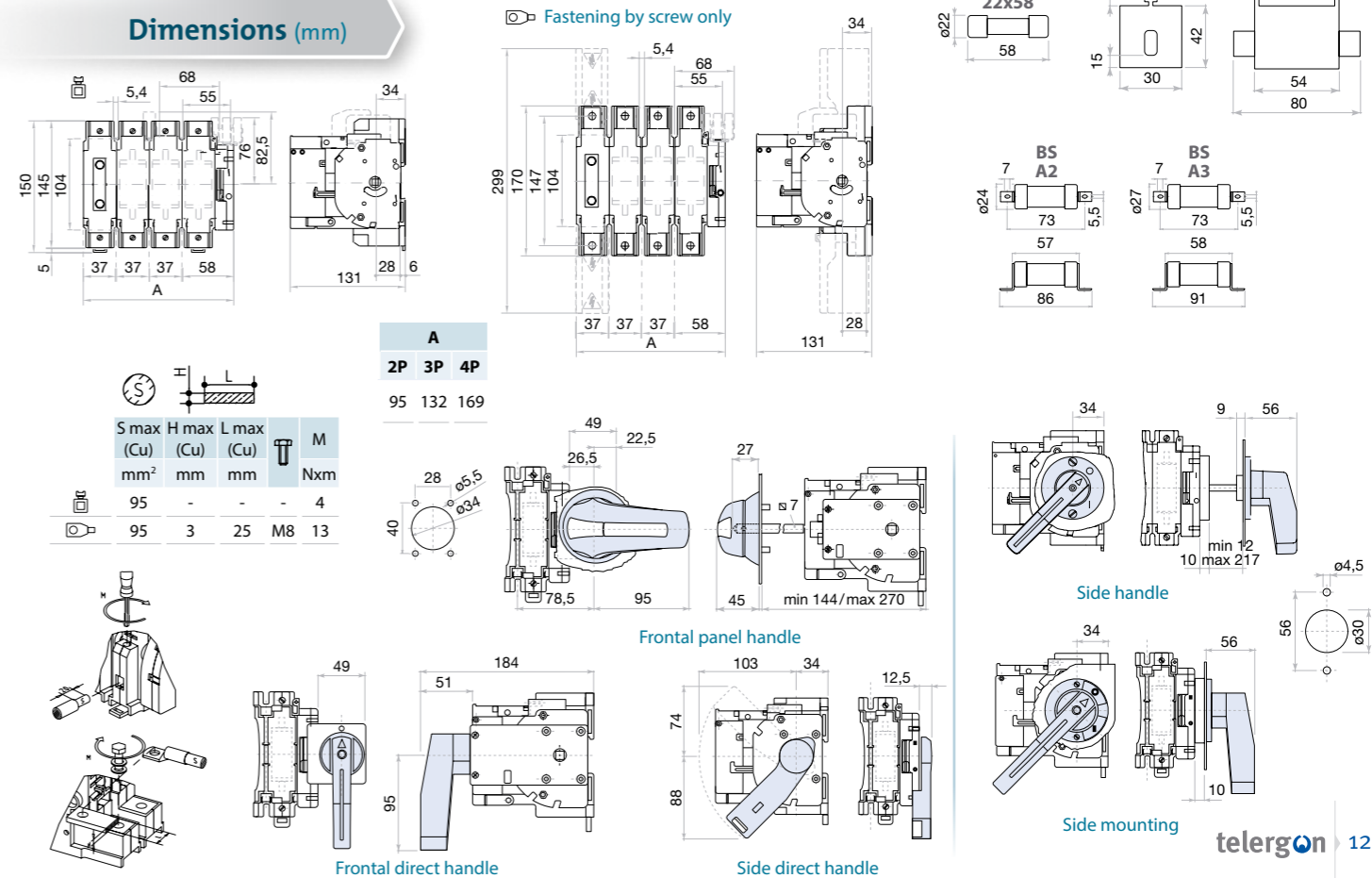

M21 Fusible switch base mounting 3P - 3P+N

Size 1	
A	160 200 250
NH 0 BS A4 BS B1 BS B2	



Fuses	CODE-160A		CODE-200A		CODE-250A	
	3P	3P+N	BS A4	BS B1-BS B2	BS B1-BS B2	BS B1-BS B2
	M2101603PSD00	M2101603NSD00	M2101603PSB10	M2101603NSB10	M2102003PSB20	M2102003NSB20
	M2101603NSD00	M2101603NSD00	M2101603NSB10	M2101603NSB10	M2102503PSB20	M2102503NSB20

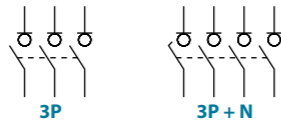

Accessories

Panel handle included shaft ^{*(e1)}
IP65|UL50E/NEMA 250
Types: 1, 3R, 4, 4X y 12
CODE DS-SA11

Emergency panel handle included shaft ^{*(e1)}
IP65|UL50E/NEMA 250
Types: 1, 3R, 4, 4X y 12
CODE DS-SR11

Direct handle
CODE DM2S11

Shafts

Standard shaft included ^{*(e1)}
L (mm) | P (mm)
227 | 180... 292

Extended shafts
Type 1
L (mm) | P (mm) | CODE
376 | 180... 441 | DS-EP14

Rear protective plate

3P	160-200 A	4P	250 A
DM2PP11		DM2PP12	DM2PP21
		DM2PP21	DM2PP22

Dimensions (mm)

Panel drilling for panel handle

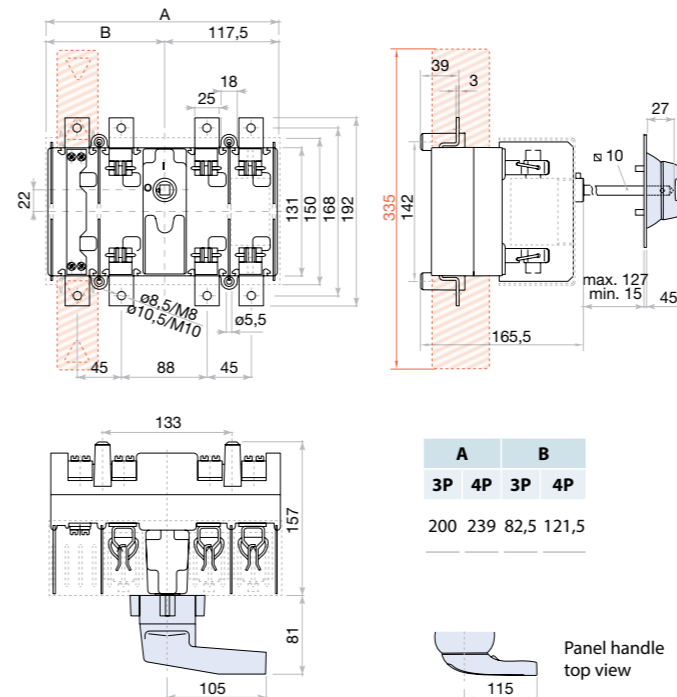

A	B
3P	4P
200	239
82,5	121,5

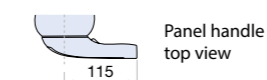

Terminal shrouds (1 kit for input or output)

3P INPUT DM2CU11	3P OUTPUT DM2CU12	4P INPUT/OUTPUT DM2CU13
---------------------	----------------------	----------------------------

Auxiliary contacts

1NO+1NC CODE DSLAU01
2NO+2NC CODE DSLAU02

Ie = 16 A (resistive loads)
4 A (inductive loads) at 250 Vac.

Safety key lock device

Simple CODE DS-CA11
Double CODE DS-CEB1

For external handle, lock the handle by means of a key in position "OFF" (under request, in "ON"), the key can only be removed with the handle locked

Panel drilling for handle and keylock device
Simple Double

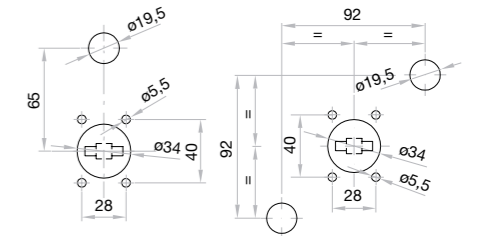

Technical information



According to IEC/EN 60947-3

		160	200	250
Fuses	NH/DIN	A 0	-	05
	BS	A A4	B1-B2	B1-B2
Rated thermal current in ambient at 40 °C	Ith	A 160	200	250
Rated thermal current in enclosure	Ithe	A 160	-	250
Rated insulation voltage	Ui	V 800	800	800
Rated dielectric strength	50 Hz, 1 min	kV 6000	6000	6000
Rated impulse withstand voltage	Uimp	kV 8	8	8
Power dissipation in fuse links ^{*(1)}	NH/DIN	W 13,5	-	17,8
	BS	11	13	16
AC rated operational current ^{*(2)}	Ie	Ue 400 V AC21A	A 160	200
		Ue 400 V AC22A	A 160	200
		Ue 400 V AC23A	A 160	250
		Ue 500 V AC21A	A 160	200
		Ue 500 V AC22A	A 160	250
		Ue 500 V AC23A	A 160	250
AC rated operational power ^{*(3)}	Pe	3x400 V AC23A	kW 90	110
			132	

		160	200	250
Rated capacitor power	400 V	kVA 60	75	100
Rated breaking capacity	400 V; cos φ = 0,35±0,45	A 1280	1600	2000
Rated making capacity	400 V; cos φ = 0,45	A 1600	2000	2500
Conditional short - circuit current				
Fuse protected short-circuit withstand ^{*(4)}	kA rms	100	100	100
Fuse protected short-circuit making ^{*(4)}	kA rms	100	100	100
Maximum cut - off current	kA (peak)	26,3	26,3	26,3
Maximum power dissipation	A ² s (x 10 ³)	478	478	478
Minimum number of mechanical operations ^{*(5)}	Cycles	10000	10000	10000
Maximum weight 3P	kg	3,1	3,1	3,1
Maximum weight 3P+N	kg	4	4	4

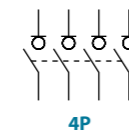

Also available 4P switches under request, consult reference

^{*(1)} Power dissipation values of fuse - links used in type tests. Please consult for fuse - links with higher power dissipation
^{*(2)} Other voltages and / or utilization categories; please consult us
^{*(3)} Indicative values: current values depend on the motor manufacturer
^{*(4)} With a protective device limiting the cut - off current and the joule integral to the indicated values
^{*(5)} Please consult us for more operations

Fuses

Maximum dimensions

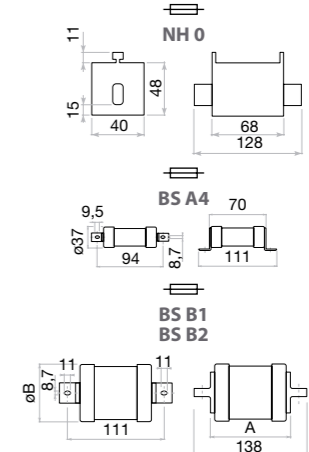

	A	øB
	max	max
B1	70	37
B2	77	42

M21 Fusible switch base mounting 3P - 3P+N

Size 2

A 250|315|400

NH 1 NH 2 BS B1
BS B2 BS B3 BS B4



Fuses	3P	CODE-250A	M2102503PSD10	CODE-400A	M2104003PSD20	CODE-315A	M2103153PSB40	CODE-400A	M2104003PSB50
	3P+N		M2102503NSD10		M2104003NSD20		M2103153NSB40		M2104003NSB50
		NH 1		NH 2		BS B1...BS B3		BS B1...BS B4	

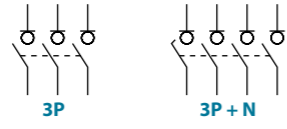

Technical information



According to IEC/EN 60947-3

		250			315			400		
Fuses	NH/DIN	A	1	-	2					
	BS	A	-	B1-B3	B1-B4					
Rated thermal current in ambient at 40 °C	Ith	A	250	315	400					
Rated thermal current in enclosure	Ithe	A	250	-	400					
Rated insulation voltage	Ui	V	1000	1000	1000					
Rated dielectric strength	50 Hz, 1 min	kV	8000	8000	8000					
Rated impulse withstand voltage	Uimp	kV	12	12	12					
Power dissipation in fuse links ^{*(1)}	NH/DIN	W	18,7	-	30					
	BS		-	24	29					
AC rated operational current ^{*(2)}	Ie	Ue 400 V AC21A	A	250	315	400				
(Rated frequency 50/60 Hz)		Ue 400 V AC22A	A	250	315	400				
		Ue 400 V AC23A	A	250	315	400				
		Ue 500 V AC21A	A	250	315	400				
		Ue 500 V AC22A	A	250	315	400				
		Ue 500 V AC23A	A	250	315	400				
AC rated operational power ^{*(3)}	Pe	3x400 V AC23A	kW	132	160	220				

		250			315			400		
Rated capacitor power	400 V	kVAr	115	150	200					
Rated breaking capacity	400 V; cos φ = 0,35±0,45	A	2000	2600	3200					
Rated making capacity	400 V; cos φ = 0,45	A	2500	3150	4000					
Conditional short - circuit current										
Fuse protected short-circuit withstand ^{*(4)}		kA rms	100	100	100					
Fuse protected short-circuit making ^{*(4)}		kA rms	100	100	100					
Maximum cut - off current		kA (peak)	43,3	43,3	43,3					
Maximum power dissipation		A ² s (x 10 ³)	1600	1600	1600					
Minimum number of mechanical operations ^{*(5)}		Cycles	10000	10000	10000					
Maximum weight 3P		kg	6,6	6,6	6,6					
Maximum weight 3P+N		kg	8	8	8					

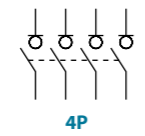

Also available 4P switches under request, consult reference

Accessories

- Panel handle** included shaft ^{*(e1)}
IP65|UL50E/NEMA 250
Types: 1, 3R, 4, 4X y 12
CODE DS-LA22
- Emergency panel handle** included shaft ^{*(e1)}
IP65|UL50E/NEMA 250
Types: 1, 3R, 4, 4X y 12
CODE DS-LR22
- Direct handle**
CODE DM2S121
- Shafts**
Standard shaft included ^{*(e1)}
L (mm) | P (mm) |
239 | 216... 286
Extended shafts
Type 1
L (mm) | P (mm) | CODE
345 | 216... 392 | DS-EP23
- Rear protective plate**
3P | 4P |
DM2PP21 | DM2PP22

Dimensions (mm)

Panel drilling for panel handle

Panel handle top view

	A	B	C	D	E
3P	250	115	212	242	4
4P	315	166	242	246	5

Terminal shrouds (1 kit for input or output)

3P INPUT DM2CU21	3P OUTPUT DM2CU22	4P INPUT/OUTPUT DM2CU23
---------------------	----------------------	----------------------------

Auxiliary contacts

1NO+1NC	CODE DSLAU01
2NO+2NC	CODE DSLAU02

Ie = 16 A (resistive loads)
4 A (inductive loads) at 250 Vac.

Safety key lock device

Simple	CODE DS-CB21
Double	CODE DS-CF21

For external handle, lock the handle by means of a key in position "OFF" (under request, in "ON"), the key can only be removed with the handle locked

Panel drilling for handle and keylock device
Simple Double

S max (Cu)	H max (Cu)	L max (Cu)	M
mm ²	mm	mm	Nxm
240	6	40	M10 24

Fuses

Maximum dimensions

	A	øB	D	G	H	J
	max	max	max	nom	nom	min
B1	70	37				
B2	77	42	138	111	8,7	11
B3						
B4	83	66				

M21 Fusible switch base mounting 3P - 3P+N

Size 3

A 630|800

NH 3 BS C1 BS C2
BS C3

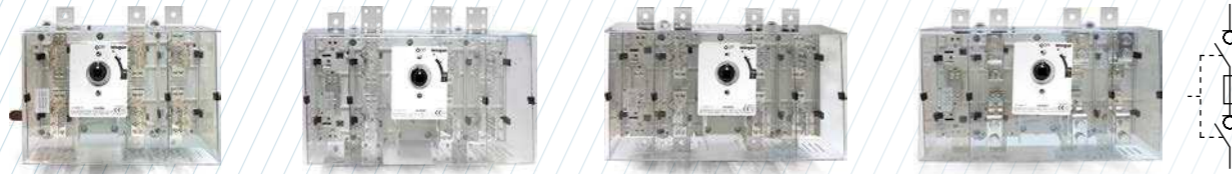

Fuses	3P	CODE-630A	M2106303PSD30	CODE-800A	M2108003PSD30
	3P+N		M2106303NSD30		M2108003NSD30
	NH 3				
	BS C1...BS C2		M2106303PSB70		M2108003PSB80
	BS C1...BS C3		M2106303NSB70		M2108003NSB80

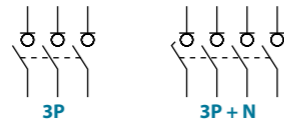

Technical information



According to IEC/EN 60947-3

		630		800	
Fuses	NH/DIN	A	3	3	
	BS	A	C1-C2	C1-C3	
Rated thermal current in ambient at 40 °C	I _{th}	A	630	800	
Rated thermal current in enclosure	I _{the}	A	630	725	
Rated insulation voltage	U _i	V	1000	1000	
Rated dielectric strength	50 Hz, 1 min	kV	8000	8000	
Rated impulse withstand voltage	U _{imp}	kV	12	12	
Power dissipation in fuse links ^{*(1)}	NH/DIN	W	48	57	
	BS		44	63	
AC rated operational current ^{*(2)}	U _e 400 V AC21A	A	630	800	
(Rated frequency 50/60 Hz)	U _e 400 V AC22A	A	630	800	
	U _e 400 V AC23A	A	630	630	
	U _e 500 V AC21A	A	630	800	
	U _e 500 V AC22A	A	630	800	
	U _e 500 V AC23A	A	630	630	
AC rated operational power ^{*(3)}	Pe	3x400 V AC23A	kW	355	355

		630		800	
Rated capacitor power	400 V	kVar	250	325	
Rated breaking capacity	400 V; cos φ = 0,35÷0,45	A	5100	5100	
Rated making capacity	400 V; cos φ = 0,45	A	6300	6300	
Conditional short - circuit current					
Fuse protected short-circuit withstand ^{*(4)}		kA rms	100	100	
Fuse protected short-circuit making ^{*(4)}		kA rms	100	100	
Maximum cut - off current		kA (peak)	60,8	60,8	
Maximum power dissipation		A ² s (x 10 ³)	4600	4600	
Minimum number of mechanical operations ^{*(5)}		Cycles	5000	5000	
Maximum weight 3P		kg	13	13	
Maximum weight 3P+N		kg	15	15	

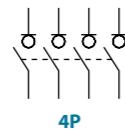

Also available 4P switches under request, consult reference

^{*(1)} Power dissipation values of fuse - links used in type tests. Please consult for fuse - links with higher power dissipation
^{*(2)} Other voltages and / or utilization categories; please consult us
^{*(3)} Indicative values: current values depend on the motor manufacturer
^{*(4)} With a protective device limiting the cut - off current and the joule integral to the indicated values
^{*(5)} Please consult us for more operations

Accessories

Panel handle included shaft ^{*(e1)}
IP65|UL50E/NEMA 250
Types: 1, 3R, 4, 4X y 12
CODE DS-LA31

Emergency panel handle included shaft ^{*(e1)}
IP65|UL50E/NEMA 250
Types: 1, 3R, 4, 4X y 12
CODE DS-LR31

Direct handle
CODE DM2S131

Shafts
Standard shaft included ^{*(e1)}
L (mm) | P (mm) |
186 | 235... 286 |

Extended shafts
Type 1
L (mm) | P (mm) | CODE
345 | 235... 445 | DS-EP23

Rear protective plate
3P | 4P |
DM2PP31 | DM2PP32 |

Dimensions (mm)

Panel drilling for panel handle

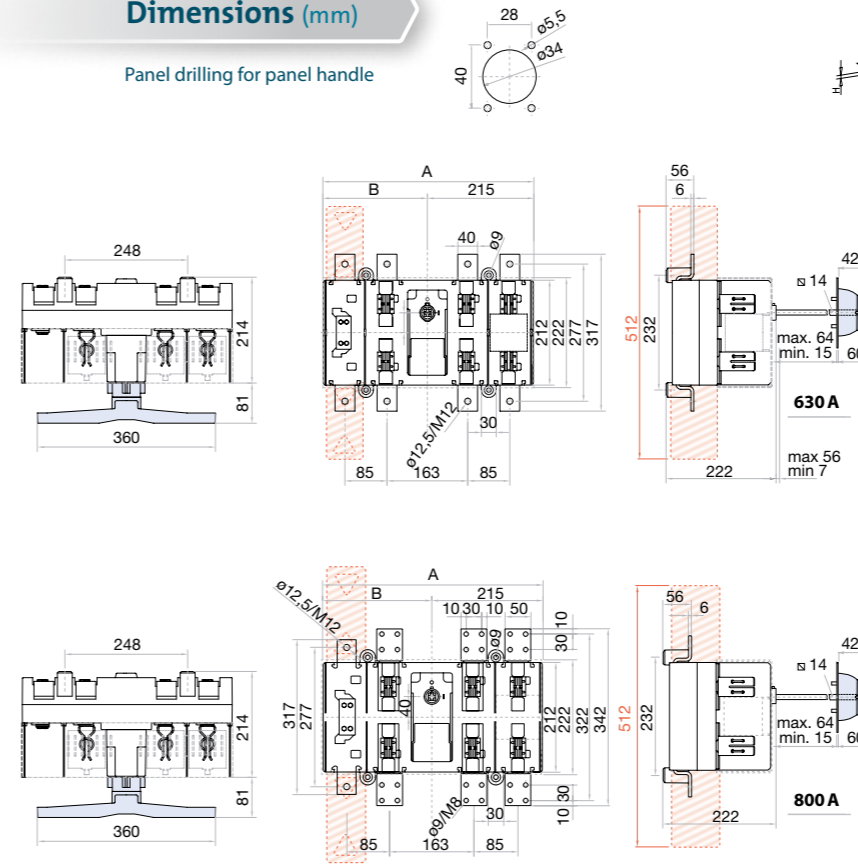

Terminal shrouds (1 kit for input or output)

3P INPUT DM2CU31	3P OUTPUT DM2CU32	4P INPUT/OUTPUT DM2CU33
---------------------	----------------------	----------------------------

Auxiliary contacts

1NO+1NC CODE DSLAU01
2NO+2NC CODE DSLAU02

I_e = 16 A (resistive loads)
4 A (inductive loads) at 250 Vac.

Safety key lock device

Simple CODE DS-CB31
Double CODE DS-CF31

For external handle, lock the handle by means of a key in position "OFF" (under request, in "ON"), the key can only be removed with the handle locked

Panel drilling for handle and keylock device
Simple | Double

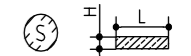
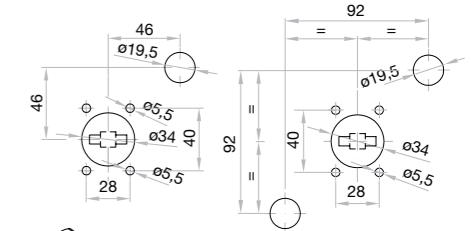

S max (Cu) mm ²	H max (Cu) mm	L max (Cu) mm	T M	M Nxmm
630 A	2x185	2x7	50	M12 45
800 A	2x240	2x7	50	M8 13

Fuses

Maximum dimensions

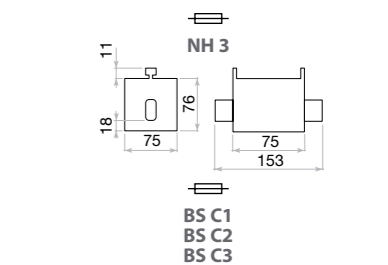

A		B	
3P	4P	3P	4P
381	426	166	211

	A	ØB	D	G	H	J	L
	max	max	max	nom	nom	min	min
C1	83	66				11	
C2	85	77	212	133	10,3		25,4
C3	89	84					12,5

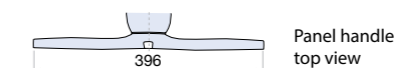

Panel handle top view

CIF21 Metal enclosed fusible switch IP65 3P - 3P+N

Size 00
A 63|100

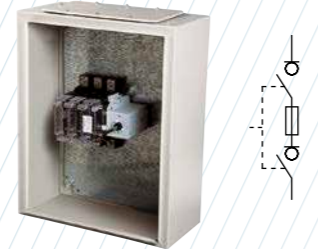

	CODE-63A	CODE-100A
3P	CIF21C00633PBDB	CIF21C01003PBDB
3P+N	CIF21C00633NBDB	CIF21C01003NBDB

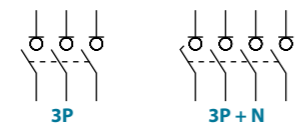

Accessories

- Panel handle** included IP65
- Emergency panel handle** under request IP65
- Auxiliary contacts**
1NO+1NC CODE DM1AUB1
2NO+2NC CODE DM1AUB2
Ie = 16 A (resistive loads)
4 A (inductive loads) at 250 Vac.



Safety key lock device
Simple CODE DS-CAB1
Double CODE DS-CEB1
For external handle, lock the handle by means of a key in position "OFF" (under request, in "ON"), the key can only be removed with the handle locked

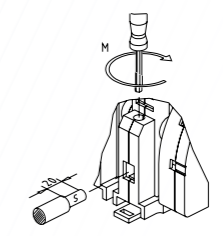

S max (Cu)	M
mm ²	Nxm
35	3

Dimensions (mm)

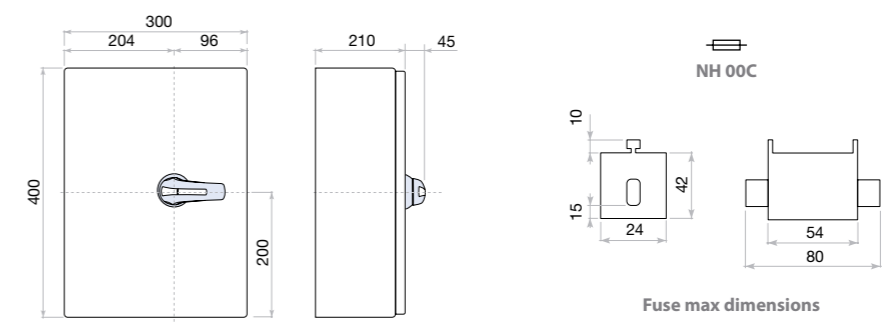

Technical information



According to IEC/EN 60947-3
IEC/EN 61439-1

			63	100
Fuses	NH/DIN	00C	00C	
Rated thermal current in enclosure 40°C	I _{the}	A	63	100
Rated insulation voltage	U _i	V	800	800
Rated dielectric strength	50 Hz, 1 min	V	5000	5000
Rated impulse withstand voltage	U _{imp}	kV	8	8
Power dissipation in fuse links ^{*(1)}	NH/DIN	W	5,1	6,9
	BS		6,6	-
	NFC		-	-
AC rated operational current ^{*(2)}	I _e	400 V AC21A	A	63
		400 V AC22A	A	63
		400 V AC23A	A	63
		500 V AC21A	A	63
		500 V AC22A	A	63
		500 V AC23A	A	80
AC rated operational power ^{*(3)}	P _e	400 V AC23A	kW	30
				55

			63	100
Rated capacitor power	400 V	kVA _r	25	42
Rated breaking capacity	400 V; cos φ = 0,35÷0,45	A	504	800
Rated making capacity	400 V; cos φ = 0,45	A	800	1000
Short - circuit behaviour				
Short - time withstand current ^{*(4)}		kA rms	100	100
Short - circuit making current ^{*(4)}		kA rms	50	50
Maximum cut - off current		kA (peak)	13	13
Maximum power dissipation		A ² s (x 10 ³)	76	76
Minimum number of mechanical operation ^{*(5)}		Cycles	10000	10000
Maximum weight 2P		kg	Consult	
Maximum weight 3P		kg	Consult	
Maximum weight 3P+N		kg	Consult	

^{*(4)} With a protective device limiting the cut - off current and the joule integral to the indicated values
^{*(5)} Please consult us for more operations

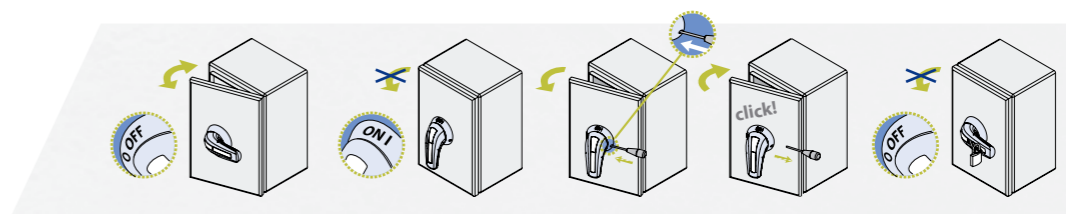
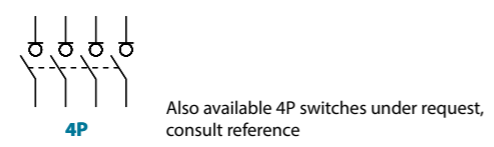

Standard supply

CIF21 Metal enclosed fusible switch IP65 3P - 3P+N

Size 0
A 125 | 160

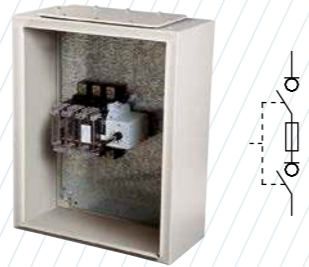

	CODE-125A	CODE-160A	CODE-125A	CODE-160A
3P	CIF21C01253PBDB	CIF21C01603PBDB	CIF21C01253PTDB	CIF21C01603PTDB
3P+N	CIF21C01253NBDB	CIF21C01603NBDB	CIF21C01253NTDB	CIF21C01603NTDB

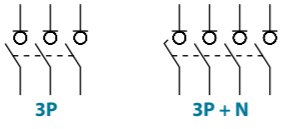

Technical information



According to IEC/EN 60947-3
IEC/EN 61439-1

			125	160
Fuses	NH/DIN		00	00
Rated thermal current in enclosure 40°C	I _{the}	A	125	160
Rated insulation voltage	U _i	V	800	800
Rated dielectric strength	50 Hz, 1 min	V	6000	6000
Rated impulse withstand voltage	U _{imp}	kV	8	8
Power dissipation in fuse links ^{*(1)}	NH/DIN	W	9,5	11,8
	BS		-	-
	NFC		12,5	-
AC rated operational current ^{*(2)}	le	400 V AC21A A	125	160
		400 V AC22A A	125	160
(Rated frequency 50/60 Hz)		400 V AC23A A	125	160
		500 V AC21A A	125	160
		500 V AC22A A	125	160
		500 V AC23A A	125	125
AC rated operational power ^{*(3)}	Pe	400 V AC23A kW	65	90

^{*(1)} Power dissipation values of fuse - links used in type tests. Please consult for fuse - links with higher power dissipation
^{*(2)} Other voltages and / or utilization categories. Please consult
^{*(3)} Indicative values: current values depend on the motor manufacturer

			125	160
Rated capacitor power	400 V	kVA _r	52	60
Rated breaking capacity	400 V; cos φ = 0,35÷0,45	A	1000	1280
Rated making capacity	400 V; cos φ = 0,45	A	1250	1600
Short - circuit behaviour				
Short - time withstand current ^{*(4)}		kA rms	100	100
Short - circuit making current ^{*(4)}		kA rms	50	50
Maximum cut - off current		kA (peak)	17	17
Maximum power dissipation		A ² s (x 10 ³)	190	190
Minimum number of mechanical operations ^{*(5)}		Cycles	10000	10000
Maximum weight 2P		kg	Consult	
Maximum weight 3P		kg	Consult	
Maximum weight 3P+N		kg	Consult	

^{*(4)} With a protective device limiting the cut - off current and the joule integral to the indicated values
^{*(5)} Please consult us for more operations

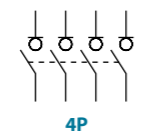

Also available 4P switches under request, consult reference

Accessories

- Panel handle** included IP65
- Emergency panel handle** under request IP65
- Auxiliary contacts**
 1NO+1NC CODE DM1AUB1
 2NO+2NC CODE DM1AUB2
 I_e = 16 A (resistive loads)
 4 A (inductive loads) at 250 Vac.

Terminal shrouds

(1 kit for input or output)
 2 UNITS | 3 UNITS
 DM1CU01 | DM1CU02

Safety key lock device

Simple CODE DS-CAB1
 Double CODE DS-CEB1

For external handle, lock the handle by means of a key in position "OFF" (under request, in "ON"), the key can only be removed with the handle locked

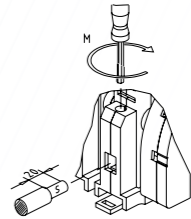

	S max (Cu) mm ²	M Nxm
125 A	95	4
160 A		

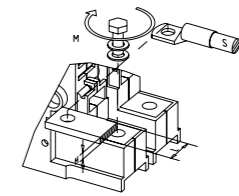

	S max (Cu) mm ²	H max (Cu) mm	L max (Cu) mm	M Nxm
125 A	95	3	25	M8 13
160 A				

Dimensions (mm)

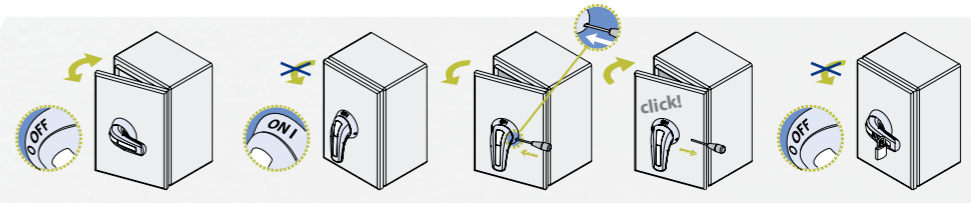
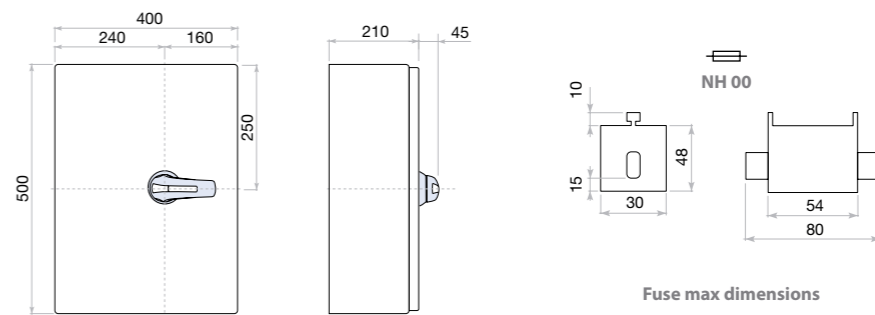

Standard supply

CIF22 Metal enclosed fusible switch IP65 3P - 3P+N

Size 1
A 160



CODE-160A 
3P CIF22C01603PSD0
3P+N CIF22C01603NSD0

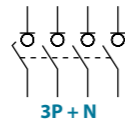
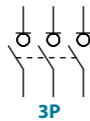

Technical information



According to IEC/EN 60947-3
IEC/EN 61439-1

		160	
Fuses	NH/DIN	0	
Rated thermal current in enclosure 40°C	I _{the}	A	160
Rated insulation voltage	U _i	V	800
Rated dielectric strength	50 Hz, 1 min	kV	6000
Rated impulse withstand voltage	U _{imp}	kV	8
Power dissipation in fuse links ^{*(1)}	NH/DIN	W	13,5
	BS		11
AC rated operational current ^{*(2)}	le	Ue 400 V	AC21A A 160
		Ue 400 V	AC22A A 160
		Ue 400 V	AC23A A 160
(Rated frequency 50/60 Hz)		Ue 500 V	AC21A A 160
		Ue 500 V	AC22A A 160
		Ue 500 V	AC23A A 160
AC rated operational power ^{*(3)}	Pe	3x400 V	AC23A kW 90

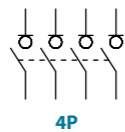

^{*(1)} Power dissipation values of fuse - links used in type tests. Please consult for fuse - links with higher power dissipation
^{*(2)} Other voltages and/or utilization categories; please consult us
^{*(3)} Indicative values: current values depend on the motor manufacturer
^{*(4)} With a protective device limiting the cut - off current and the joule integral to the indicated values
^{*(5)} Please consult us for more operations

		160	
Rated capacitor power	400 V	kVAr	60
Rated breaking capacity	400 V; cos φ = 0,35÷0,45	A	1280
Rated making capacity	400 V; cos φ = 0,45	A	1600
Conditional short - circuit current			
Fuse protected short-circuit withstand ^{*(4)}		kA rms	100
Fuse protected short-circuit making ^{*(4)}		kA rms	100
Maximum cut - off current		kA (peak)	26,3
Maximum power dissipation		A ² s (x 10 ³)	478
Minimum number of mechanical operations ^{*(5)}		Cycles	10000
Maximum weight 3P		kg	Consult
Maximum weight 3P+N		kg	Consult



Also available 4P switches under request, consult reference

Accessories

-  **Panel handle** included
IP65 | UL50E/NEMA 250
Types: 1, 3R, 4, 4X y 12
-  **Emergency panel handle** under request
IP65 | UL50E/NEMA 250
Types: 1, 3R, 4, 4X y 12
-  **Auxiliary contacts**
1NO+1NC CODE D5LAU01
2NO+2NC CODE D5LAU02
I_e = 16 A (resistive loads)
4 A (inductive loads) at 250 Vac.

Terminal shrouds

(1 kit for input or output)

INPUT 3P	OUTPUT 3P	INPUT/OUTPUT 4P
DM2CU11	DM2CU12	DM2CU13

Safety key lock device

Simple CODE DS-CA11
Double CODE DS-CEB1

For external handle, lock the handle by means of a key in position "OFF" (under request, in "ON"), the key can only be removed with the handle locked

Dimensions (mm)

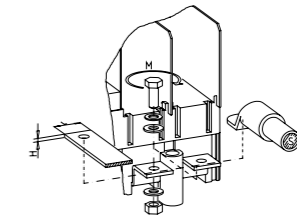
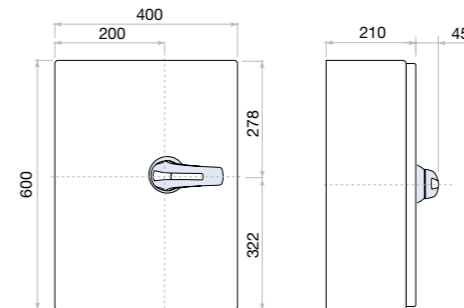

S max (Cu) mm ²	H max (Cu) mm	L max (Cu) mm	M Nxm
120	5	25	M8 13

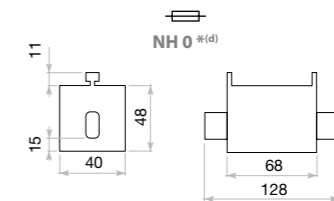

Fuse max dimensions

^{*(d)} Other fuses type, may be required changing the dimensions, please consult

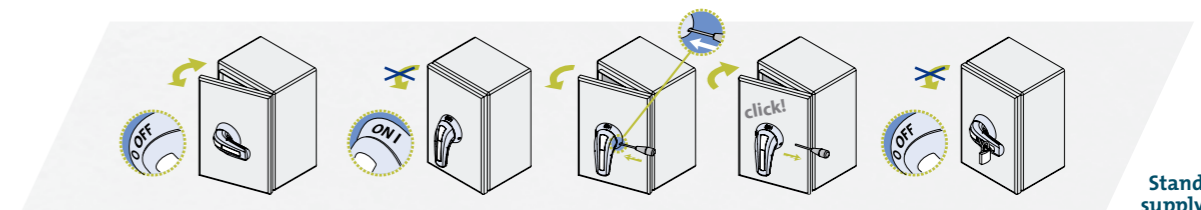

Standard supply

CIF22 Metal enclosed fusible switch IP65 3P - 3P+N

Size 2
A 250 | 400



	CODE-250A	CODE-400A
3P	CIF22C02503PSD1	CIF22C04003PSD2
3P + N	CIF22C02503NSD1	CIF22C04003NSD2

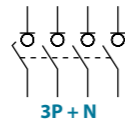
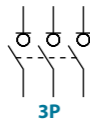

Technical information



According to IEC/EN 60947-3
IEC/EN 61439-1

		250	400
Fuses	NH/DIN	1	2
Rated thermal current in enclosure 40°C	I _{the}	A 250	400
Rated insulation voltage	U _i	V 1000	1000
Rated dielectric strength	50 Hz, 1 min	kV 8000	8000
Rated impulse withstand voltage	U _{imp}	kV 12	12
Power dissipation in fuse links ^{*(1)}	NH/DIN	W 18,7	30
	BS	-	29
AC rated operational current ^{*(2)}	le	Ue 400 V AC21A	A 250 400
		Ue 400 V AC22A	A 250 400
(Rated frequency 50/60 Hz)		Ue 400 V AC23A	A 250 400
		Ue 500 V AC21A	A 250 400
		Ue 500 V AC22A	A 250 400
		Ue 500 V AC23A	A 250 400
AC rated operational power ^{*(3)}	Pe	3x400 V AC23A	kW 132 220

		250	400
Rated capacitor power	400 V	kVA _r 115	200
Rated breaking capacity	400 V; cos φ = 0,35÷0,45	A 2000	3200
Rated making capacity	400 V; cos φ = 0,45	A 2500	4000
Conditional short - circuit current			
Fuse protected short-circuit withstand ^{*(4)}		kA rms 100	100
Fuse protected short-circuit making ^{*(4)}		kA rms 100	100
Maximum cut - off current		kA (peak) 43,3	43,3
Maximum power dissipation		A ² s (x 10 ³) 1600	1600
Minimum number of mechanical operations ^{*(5)}		Cycles 10000	10000
Maximum weight 3P		kg	Consult
Maximum weight 3P+N		kg	Consult

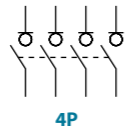

También disponibles interruptores 4P bajo pedido, consulte referencia

^{*(1)} Power dissipation values of fuse - links used in type tests. Please consult for fuse - links with higher power dissipation
^{*(2)} Other voltages and/or utilization categories; please consult us
^{*(3)} Indicative values: current values depend on the motor manufacturer
^{*(4)} With a protective device limiting the cut - off current and the joule integral to the indicated values
^{*(5)} Please consult us for more operations

Accessories



Panel handle included
IP65 | UL50E/NEMA 250
Types: 1, 3R, 4, 4X y 12

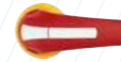

Emergency panel handle under request
IP65 | UL50E/NEMA 250
Types: 1, 3R, 4, 4X y 12



Auxiliary contacts
1NO+1NC CODE D5LAU01
2NO+2NC CODE D5LAU02
I_e = 16 A (resistive loads)
4 A (inductive loads) at 250 Vac.



Terminal shrouds
(1 kit for input or output)
INPUT 3P DM2CU21
OUTPUT 3P DM2CU22
INPUT/OUTPUT 4P DM2CU23



Safety key lock device
Simple CODE DS-CB21
Double CODE DS-CF21
For external handle, lock the handle by means of a key in position "OFF" (under request, in "ON"), the key can only be removed with the handle locked

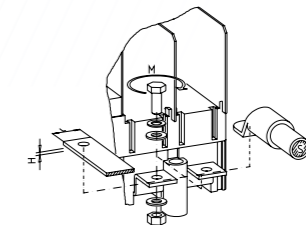

S max (Cu)	H max (Cu)	L max (Cu)	T	M
mm ²	mm	mm		Nxm
240	6	40	M10	24

Dimensions (mm)

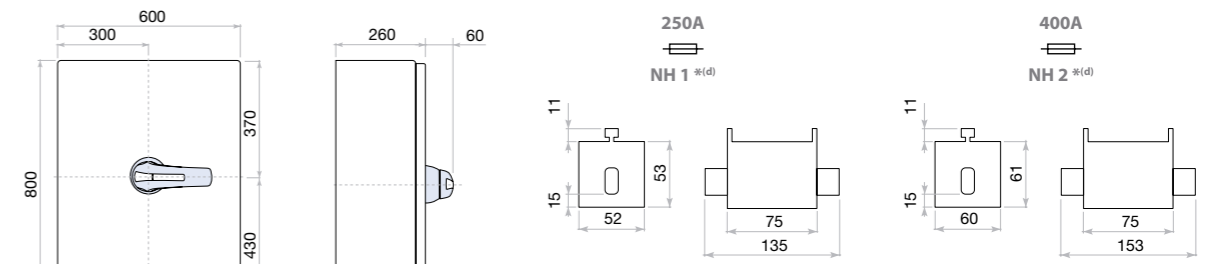

Fuse max dimensions

^{*(d)} Other fuses type, may be required changing the dimensions, please consult

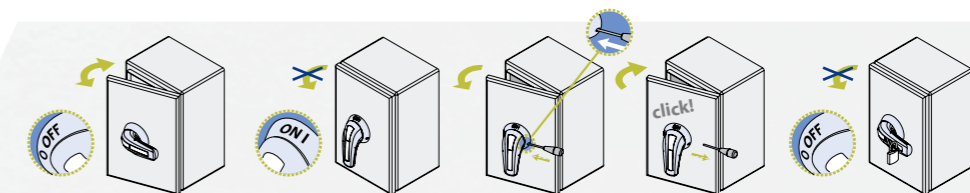

Standard supply

CIF22 Metal enclosed fusible switch IP65 3P - 3P+N

Size 3
A 630 | 800



	CODE-630A	CODE-800A
3P	CIF22C06303PSD3	CIF22C08003PSD3
3P+N	CIF22C06303NSD3	CIF22C08003NSD3

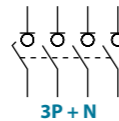
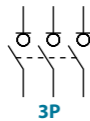

Technical information



According to IEC/EN 60947-3
IEC/EN 61439-1

		630		800	
Fuses	NH/DIN	3	3		
Rated thermal current in enclosure 40°C	I _{the}	A	630	725	
Rated insulation voltage	U _i	V	1000	1000	
Rated dielectric strength	50 Hz, 1 min	kV	8000	8000	
Rated impulse withstand voltage	U _{imp}	kV	12	12	
Power dissipation in fuse links ^{*(1)}	NH/DIN	W	48	57	
	BS		44	63	
AC rated operational current ^{*(2)}	I _e	U _e 400 V AC21A	A	630	800
		U _e 400 V AC22A	A	630	800
(Rated frequency 50/60 Hz)		U _e 400 V AC23A	A	630	630
		U _e 500 V AC21A	A	630	800
		U _e 500 V AC22A	A	630	800
		U _e 500 V AC23A	A	630	630
AC rated operational power ^{*(3)}	P _e	3x400 V AC23A	kW	355	355

		630		800	
Rated capacitor power	400 V	kVAr	250	325	
Rated breaking capacity	400 V; cos φ = 0,35÷0,45	A	5100	5100	
Rated making capacity	400 V; cos φ = 0,45	A	6300	6300	
Conditional short - circuit current					
Fuse protected short-circuit withstand ^{*(4)}		kA rms	100	100	
Fuse protected short-circuit making ^{*(4)}		kA rms	100	100	
Maximum cut - off current		kA (peak)	60,8	60,8	
Maximum power dissipation		A ² s (x 10 ³)	4600	4600	
Minimum number of mechanical operations ^{*(5)}		Cycles	5000	5000	
Maximum weight 3P		kg	Consult		
Maximum weight 3P+N		kg	Consult		

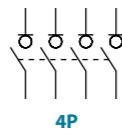

Also available 4P switches under request, consult reference

^{*(1)} Power dissipation values of fuse - links used in type tests. Please consult for fuse - links with higher power dissipation
^{*(2)} Other voltages and / or utilization categories; please consult us
^{*(3)} Indicative values: current values depend on the motor manufacturer
^{*(4)} With a protective device limiting the cut - off current and the joule integral to the indicated values
^{*(5)} Please consult us for more operations

Accessories

- Panel handle** included
IP65 | UL50E/NEMA 250
Types: 1, 3R, 4, 4X y 12
- Emergency panel handle** under request
IP65 | UL50E/NEMA 250
Types: 1, 3R, 4, 4X y 12
- Auxiliary contacts**
1NO+1NC CODE D5LAU01
2NO+2NC CODE D5LAU02
I_e = 16 A (resistive loads)
4 A (inductive loads) at 250 Vac.

Terminal shrouds

(1 kit for input or output)

INPUT 3P DM2CU31	OUTPUT 3P DM2CU32	INPUT/OUTPUT 4P DM2CU33
---------------------	----------------------	----------------------------

Safety key lock device

Simple CODE DS-CB31
Double CODE DS-CF31

For external handle, lock the handle by means of a key in position "OFF" (under request, in "ON"), the key can only be removed with the handle locked

Dimensions (mm)

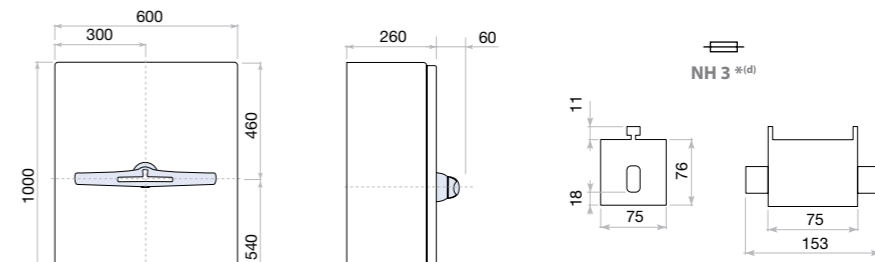

Fuse max dimensions

^{*(d)} Other fuses type, may be required changing the dimensions, please consult

	S max (Cu) mm ²	H max (Cu) mm	L max (Cu) mm	M	M
630 A	2x185	2x7	50	M12	45
800 A	2x240	2x7	50	M8	13

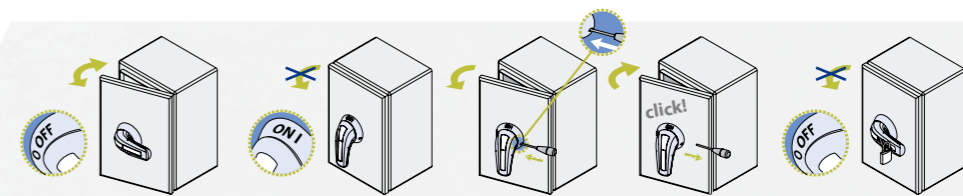

Standard supply

Changeover switches

series
CCF|CCP|S5L|S5F|S5B

Changeover switches with high operating load capacity and a high level disconnection insulation; high reliability and safety in abnormal situations, available in different construction models, with a wide range of currents, motorized units and various accessories.

According to:
IEC/EN 60947-3
IEC/EN 61439-1
RoHS



Testing and approvals:



Functional and ergonomic handle

- > Good grip and excellent torque/resistance
- > Padlockable handle in **O OFF** position (up to three locks Ø 5-8 mm)
- > Door interlock in **ON I - ON II** position
- > Self-centering shaft for door handle



The changeover switches in its different series, are manufactured with high safety self-extinguishing materials, providing an excellent level of electrical insulation, low smoke emission and high resistance to electromechanical stress.

They comply with environmental requirements and undergo strict quality controls for a reliable product that meets the most demanding requirements.

They consist of a sandwich-type body containing self-cleaning blade type contacts, with pre-arc zones to ensure long

term, fault-free energy transmission and coated with silver alloy for long electro-mechanical life. The jump mechanism provides quick and independent switching due to the accumulation of elastic potential energy, which is transmitted at high speed to the contacts for arc extinction.

The compact models are with visible cut-off and performed internally the common output without the need for external connections.

Neutral pole advanced during closing and withdrawn while opening



A safety system preventing accidental overvoltage during switching in receptors powered between phase and neutral.

Due to the design in our 3P+N switch - disconnectors and changeover switches, the neutral contact closes before the main phases and opens later, thus ensuring this operation mode.

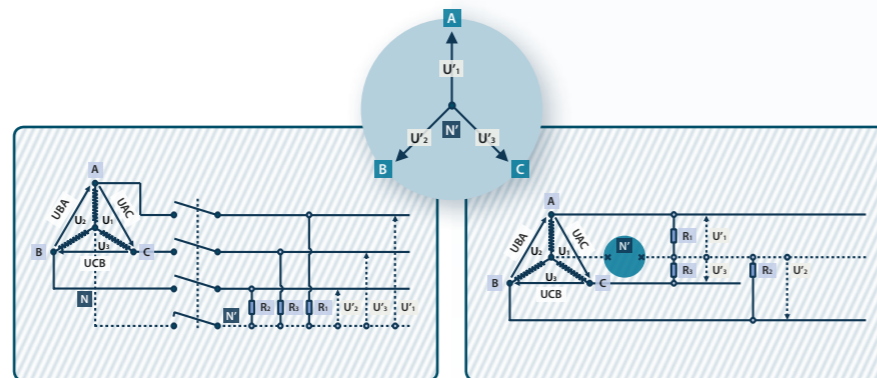

Range coding:

The CCF|CCP|S5L|S5F|CCP series, are identified by a code that describes their most important characteristics as described below

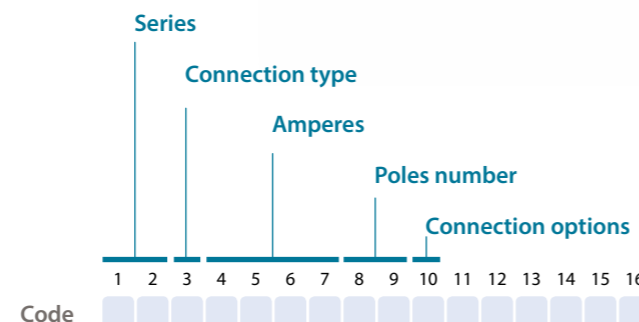

series CCF
Compact model. Visible cut-off. Common output from the front. Wide range of currents. Base mounting by screws. Panel or direct handle.

series CCP
Compact model. Visible cut-off. Common output from the rear. Wide range of currents. Base mounting by screws. Panel or direct handle.

series S5L
Line arrangement. Base mounting by screws. Panel or direct handle.

series S5F
Back to back arrangement. Base mounting by screws. Panel or direct handle.

series S5B
By-pass. Back to back arrangement. Base mounting by screws. Panel or direct handle.



series CTR2
Manual changeover switch in metallic enclosure. External padlockable handle with locking door in ON I - ON II positions.



series CTRC
Motorized changeover switch in metallic enclosure. Outdoor lights position indicators (mains - 0 - generator). Power connections on the bottom for direct access. Power part protected against accidental contact. Physical separation between power and control parts. Including manual handle (for emergency operation or maintenance). Other special combinations under request.



series CTRC
Motorized changeover switch in metallic enclosure with automatic transfer switch for the generator control with automated switching Main - Gen management. Configurable through software programming. Power part protected against accidental contact. Including manual handle (for emergency operation or maintenance).

S5000L Changeover switch base mounting 3P - 3P+N

Size 00
A 40|63|80



	CODE-40A	CODE-63A	CODE-80A
3P	S5L00403PB0	S5L00633PB0	S5L00803PB0
3P+N	S5L00403NB0	S5L00633NB0	S5L00803NB0



Technical information



According to IEC/EN 60947-3

		40			63			80		
Rated thermal current	I _{th} in ambient at 40° C	A	50	63	80					
Rated insulation voltage	U _i	V	800	800	800					
Rated dielectric strength	50 Hz, 1 min.	V	3500	3500	3500					
Rated impulse withstand voltage	U _{imp}	kV	8	8	8					
AC Rated operational current ^{*(1)} I _e (Rated operational frequency 50/60 Hz)	400V AC21A A		50	63	80					
	400V AC22A A		50	63	80					
	500V AC21A A		50	63	80					
	500V AC22A A		50	63	63					
	690V AC21A A		50	63	63					
AC Rated operational power ^{*(2)} P _e	3x400V AC23A kW		27,7	34,9	34,9					
	3x500V AC23A kW		27,7	34,6	34,6					
	3x690V AC23A kW		23,9	30,5	30,5					

		40			63			80		
Rated capacitor power	400V, sen φ=0,65	kVAr	22,5	28,3	28,3					
Rated breaking capacity	400V AC22A A	A	150	189	240					
Rated making capacity	400V AC22A A	A	150	189	240					
Short - circuit behaviour										
Short - circuit making capacity ^{*(3)} I _{cm}	kA (peak)		5	5	5					
Short - time withstand current (1 sec.) I _{cw}	kA rms		3	3	3					
Minimum number of mechanical operations ^{*(4)}		Cycles	10000	10000	10000					
Minimum number of electrical operations	400V AC22A	Cycles	1500	1500	1500					
Maximum weight (3/4 poles)		Kg	0,8/0,8	0,8/0,8	0,8/0,8					

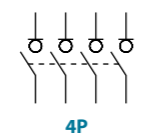

Also available 4P changeover switches under request, consult reference

^{*(1)} Other voltages and / or utilization categories. Please consult
^{*(2)} Indicative values, value cos φ=0,8
^{*(3)} Without limiting protective device (short-circuit maintained 50 ms. - 100 ms.)
^{*(4)} Please consult us for more operations

Accessories

Direct handle
CODE D5LSI01

Bridging links (4 pieces)
CODE D5LPCB1

Panel handle included shaft ^{*(e1)}
IP65
CODE D5LLA01

Auxiliary contacts
1NO+1NC CODE D5LAU01
2NO+2NC CODE D5LAU02
I_e = 16 A (resistive loads)
4 A (inductive loads) at 250 Vac.

Shafts
Standard shaft included ^{*(e1)}
L (mm) | P (mm)
177 | 85... 180,5

Shaft extensions
Type 1
L (mm) | P (mm) | CODE
250 | 85... 253,5 | DS-EP04
Type 2
L (mm) | P (mm) | CODE
387 | 85... 390,5 | DS-EP05

Safety key lock devices
Simple CODE D5LCBB1
Double CODE D5LCBB1
For external handle, lock the handle by means of a key in position "OFF" (under request, in "ON"), the key can only be removed with the handle locked

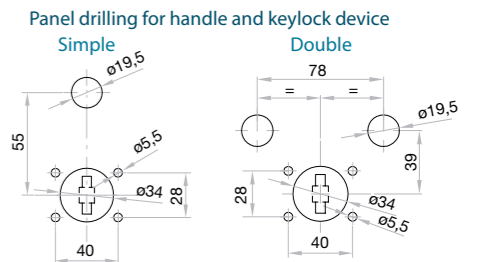

Dimensions (mm)

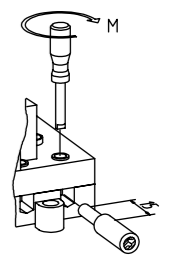
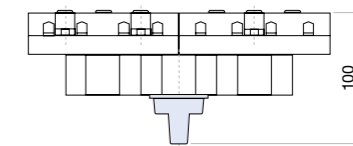
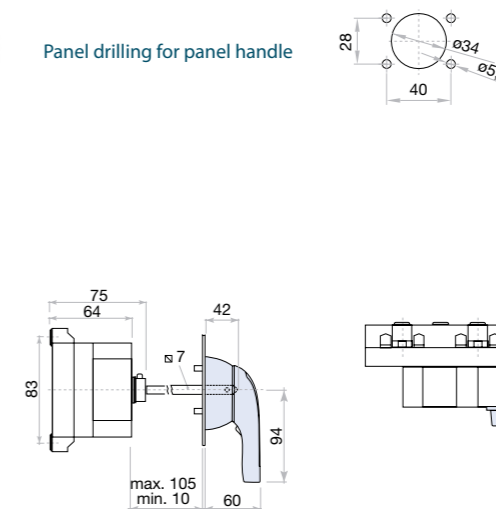
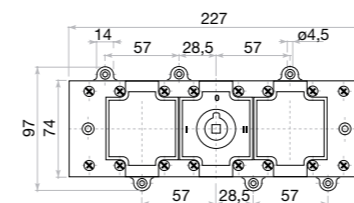

S max (Cu)	M
mm ²	Nxm
25	2

S5000L | S5000F

Changeover switch base mounting 3P - 3P+N

Size 0

A 125|160|200

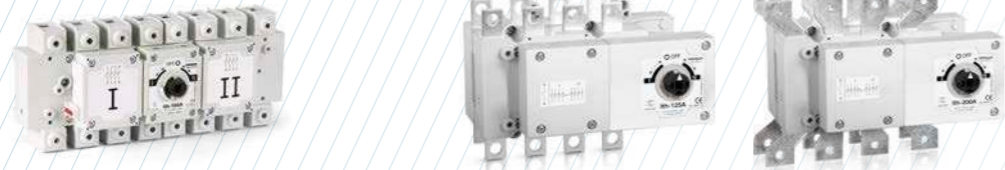

	CODE-125A	CODE-160A	CODE-125A	CODE-160A	CODE-200A
3P	S5L01253PB0	S5L01603PB0	S5F01253PS0	S5F01603PS0	S5F02003PS0
3P+N	S5L01253NB0	S5L01603NB0	S5F01253NS0	S5F01603NS0	S5F02003NS0



Technical information



According to IEC/EN 60947-3

			125	160	200
Rated thermal current	I _{th} in ambient at 40°C	A	125	160	200
Rated insulation voltage	U _i	V	1000	1000	1000
Rated dielectric strength	50 Hz, 1 min.	V	4000	4000	4000
Rated impulse withstand voltage	U _{imp}	kV	8	8	8
AC Rated operational current ^{*(1)}	I _e	400V AC21A A	125	160	200
(Rated operational frequency 50/60 Hz)		400V AC22A A	125	160	200
		500V AC21A A	125	160	200
		500V AC22A A	125	160	200
		690V AC21A A	125	160	180
		690V AC22A A	100	125	160
		800V AC20A A	125	160	200
		1000V AC20A A	125	160	200
AC Rated operational power ^{*(2)}	P _e	3x400V AC23A kW	69,2	88,6	88,6
		3x500V AC23A kW	69,2	88,6	88,6
		3x690V AC23A kW	76,4	76,4	76,4

			125	160	200
Rated capacitor power	400V, sen φ=0,65	kVA	56,2	72	90
Rated breaking capacity	400V AC22A	A	375	480	600
Rated making capacity	400V AC22A	A	375	480	600
Short - circuit behaviour					
Short - circuit making capacity ^{*(3)}	I _{cm}	kA (peak)	13	13	13
Short - time withstand current (1 sec.)	I _{cw}	kA rms	7	7	7
Minimum number of mechanical operations ^{*(4)}		Cycles	10000	10000	10000
Minimum number of electrical operations	400V AC22A	Cycles	1000	1000	1000
Maximum weight (3/4 poles)	SSL	Kg	1,8/2	1,8/2	-
	S5F	Kg	1,8/2,1	1,8/2,1	1,9/2,2

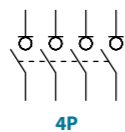

Also available 4P changeover switches under request, consult reference

^{*(1)} Other voltages and / or utilization categories. Please consult
^{*(2)} Indicative values, value cos φ=0,8
^{*(3)} Without limiting protective device (short-circuit maintained 50 ms. - 100 ms.)
^{*(4)} Please consult us for more operations

tests:



Accessories

- Direct handle**
CODE D5LSI01
- Panel handle** included shaft ^{*(e1)}
IP65
CODE D5LLA01
- Shafts**
Standard shaft included ^{*(e1)}

L (mm)	P (mm)
S5F 177	163... 250,5
SSL 177	87... 198

Shaft extensions
Type 1

L (mm)	P (mm)	CODE
S5F 250	163... 323,5	DS-EP04
SSL 250	87... 271	DS-EP04

Type 2

L (mm)	P (mm)	CODE
S5F 387	163... 460,5	DS-EP05
SSL 387	87... 408	DS-EP05
- Auxiliary contacts**
1NO+1NC CODE S5F DS-AU11
CODE SSL D5LAU01
2NO+2NC CODE S5F DS-AU12
CODE S5F D5LAU02

I_e = 16 A (resistive loads)
4 A (inductive loads) at 250 Vac.

Dimensions (mm)

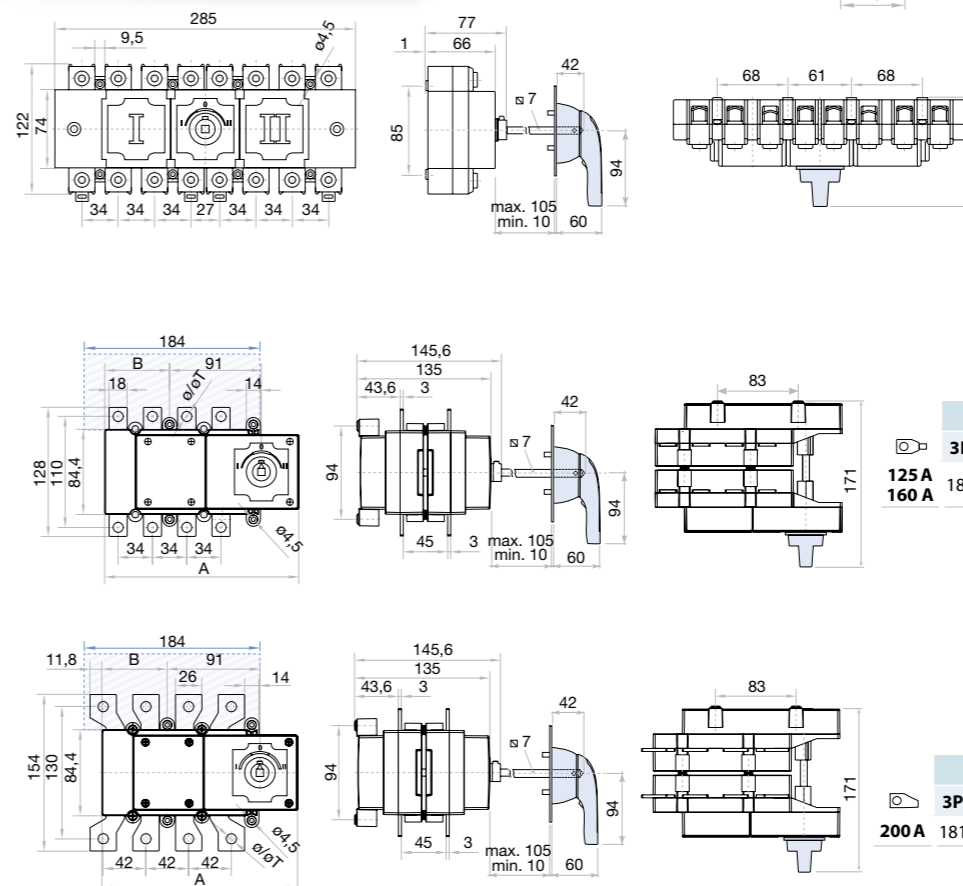

Panel drilling for panel handle

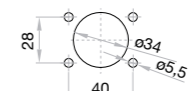

Terminal protection

CODE DS-CU01
(1 unit for input or output only frontal side)

Bridging links (4 pieces)

CODE S5F D5LPC03
CODE SSL D5LPC01

DIN rail mounting

CODE DS-DN01
(only for SSL changeover switches, order two kits)

Safety key lock devices

Simple CODE D5LCBB1
Double CODE D5LCBB1

For external handle, lock the handle by means of a key in position "OFF" (under request, in "ON"), the key can only be removed with the handle locked

Panel drilling for handle and keylock device

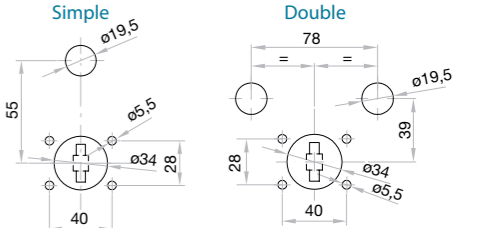

	S max (Cu)	M
125 A	95	4
160 A	95	4

	A	B	ø T
125 A	181	192	53
160 A	181	192	53

S max (Cu)	H max (Cu)	L max (Cu)	M
mm ²	mm	mm	Nxm
95	5	25	M8

	A	B	ø T
200 A	181	192	53
	181	192	53

S max (Cu)	H max (Cu)	L max (Cu)	M
mm ²	mm	mm	Nxm
120	5	30	M10

CCF/CCP Changeover switch base mounting 3P - 3P+N

Size 1
A 200|250|315|400



CCF	3P	CODE - 200A				CODE - 250A				CODE - 315A				CODE - 400A			
		CCF02003PS0	CCF02503PS0	CCF03153PS0	CCF04003PS0	CCF02003NS0	CCF02503NS0	CCF03153NS0	CCF04003NS0	CCF02003PS0	CCF02503PS0	CCF03153PS0	CCF04003PS0	CCF02003NS0	CCF02503NS0	CCF03153NS0	CCF04003NS0
CCP	3P	CCP02003PS0	CCP02503PS0	CCP03153PS0	CCP04003PS0	CCP02003NS0	CCP02503NS0	CCP03153NS0	CCP04003NS0	CCP02003PS0	CCP02503PS0	CCP03153PS0	CCP04003PS0	CCP02003NS0	CCP02503NS0	CCP03153NS0	CCP04003NS0
		CCP02003NS0	CCP02503NS0	CCP03153NS0	CCP04003NS0	CCP02003NS0	CCP02503NS0	CCP03153NS0	CCP04003NS0	CCP02003NS0	CCP02503NS0	CCP03153NS0	CCP04003NS0	CCP02003NS0	CCP02503NS0	CCP03153NS0	CCP04003NS0

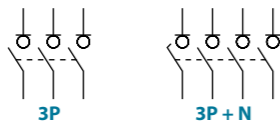

Technical information



According to IEC/EN 60947-3

		200				250				315				400							
Rated thermal current	I _{th} in ambient at 40° C	A	200	250	315	400	A	200	250	315	400	A	200	250	315	400	A	200	250	315	400
Rated insulation voltage	U _i	V	1000	1000	1000	1000	V	1000	1000	1000	1000	V	1000	1000	1000	1000	V	1000	1000	1000	1000
Rated dielectric strength	50 Hz, 1 min.	V	6000	6000	6000	6000	V	6000	6000	6000	6000	V	6000	6000	6000	6000	V	6000	6000	6000	6000
Rated impulse withstand voltage	U _{imp}	kV	8	8	8	8	kV	8	8	8	8	kV	8	8	8	8	kV	8	8	8	8
AC Rated operational current ^{*(1)} (Rated operational frequency 50/60 Hz)	I _e	400V AC21A A	200	250	315	400	400V AC21A A	200	250	315	400	400V AC21A A	200	250	315	400	400V AC21A A	200	250	315	400
		400V AC22A A	200	250	315	400	400V AC22A A	200	250	315	400	400V AC22A A	200	250	315	400	400V AC22A A	200	250	315	400
		500V AC21A A	200	250	315	400	500V AC21A A	200	250	315	400	500V AC21A A	200	250	315	400	500V AC21A A	200	250	315	400
		500V AC22A A	200	250	315 ^{*(5)}	400 ^{*(5)}	500V AC22A A	200	250	315 ^{*(5)}	400 ^{*(5)}	500V AC22A A	200	250	315 ^{*(5)}	400 ^{*(5)}	500V AC22A A	200	250	315 ^{*(5)}	400 ^{*(5)}
		690V AC21A A	200	250	315	400	690V AC21A A	200	250	315	400	690V AC21A A	200	250	315	400	690V AC21A A	200	250	315	400
		690V AC22A A	160	200	250	315 ^{*(5)}	690V AC22A A	160	200	250	315 ^{*(5)}	690V AC22A A	160	200	250	315 ^{*(5)}	690V AC22A A	160	200	250	315 ^{*(5)}
AC Rated operational power ^{*(2)}	P _e	3x400V AC23A kW	80	90	100	125	3x400V AC23A kW	80	90	100	125	3x400V AC23A kW	80	90	100	125	3x400V AC23A kW	80	90	100	125
		3x500V AC23A kW	78	94	100	125	3x500V AC23A kW	78	94	100	125	3x500V AC23A kW	78	94	100	125	3x500V AC23A kW	78	94	100	125
		3x690V AC23A kW	69	86	108	138	3x690V AC23A kW	69	86	108	138	3x690V AC23A kW	69	86	108	138	3x690V AC23A kW	69	86	108	138

		200				250				315				400													
Rated capacitor power	400V, sen φ=0,65	kVar	90	104	131	166	400V, sen φ=0,65	90	104	131	166	400V, sen φ=0,65	90	104	131	166	400V, sen φ=0,65	90	104	131	166						
Rated breaking capacity	400V AC22A	A	600	750	945	1200	400V AC22A	600	750	945	1200	400V AC22A	600	750	945	1200	400V AC22A	600	750	945	1200						
Rated making capacity	400V AC22A	A	600	750	945	1200	400V AC22A	600	750	945	1200	400V AC22A	600	750	945	1200	400V AC22A	600	750	945	1200						
Short - circuit behaviour																											
Short - circuit making capacity ^{*(3)}	I _{cm}	kA (peak)	12	12	12	12	Short - circuit making capacity ^{*(3)}	12	12	12	12	Short - circuit making capacity ^{*(3)}	12	12	12	12	Short - circuit making capacity ^{*(3)}	12	12	12	12						
Short - time withstand current (1 sec.)	I _{cw}	kA rms	8	8	8	8	Short - time withstand current (1 sec.)	8	8	8	8	Short - time withstand current (1 sec.)	8	8	8	8	Short - time withstand current (1 sec.)	8	8	8	8						
Minimum number of mechanical operations ^{*(4)}		Cycles	10000	10000	10000	10000	Minimum number of mechanical operations ^{*(4)}	10000	10000	10000	10000	Minimum number of mechanical operations ^{*(4)}	10000	10000	10000	10000	Minimum number of mechanical operations ^{*(4)}	10000	10000	10000	10000						
Minimum number of electrical operations	400V AC22A	Cycles	1000	1000	1000	1000	Minimum number of electrical operations	1000	1000	1000	1000	Minimum number of electrical operations	1000	1000	1000	1000	Minimum number of electrical operations	1000	1000	1000	1000						
Maximum weight (3/4 poles)		Kg	4,8/5,3	4,8/5,3	5/5,5	5/5,5	Maximum weight (3/4 poles)		Kg	4,8/5,3	4,8/5,3	5/5,5	5/5,5	Maximum weight (3/4 poles)		Kg	4,8/5,3	4,8/5,3	5/5,5	5/5,5	Maximum weight (3/4 poles)		Kg	4,8/5,3	4,8/5,3	5/5,5	5/5,5
		CCF	5,3/5,9	5,3/5,9	5/5,6	5/5,6			CCP	5,3/5,9	5,3/5,9	5/5,6	5/5,6			CCP	5,3/5,9	5,3/5,9	5/5,6	5/5,6			CCP	5,3/5,9	5,3/5,9	5/5,6	5/5,6

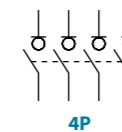

Also available 4P changeover switches under request, consult reference

^{*(1)} Other voltages and/or utilization categories; please consult
^{*(2)} Indicative values, value cos φ=0,8
^{*(3)} Without limiting protective device (short - circuit maintained 50 ms. - 100 ms.)
^{*(4)} Please consult us for more operations
^{*(5)} AC22B



Accessories



Direct handle
CODE DCCL11

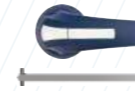

Panel handle included shaft ^{*(e1)}
IP65|UL50E/NEMA 250
Types: 1, 3R, 4, 4X y 12
CODE DCCLA11

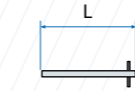

Shafts
Standard shaft included ^{*(e1)}
L (mm) | P (mm) |
227 | 166... 293



Shaft extensions
Type 1
L (mm) | P (mm) | CODE
376 | 166... 442 | DS-EP14
Type 2
L (mm) | P (mm) | CODE
536 | 166... 602 | DS-EP15



Rear protective plate
3P | 4P
DCCPP11 | DCCPP12



Terminal shrouds
Inputs | Common output
POS. I | POS. II | POS. I&II |
3P | 3P | 3P+N |
DM2CU12 | DM2CU11 | DM2CU13 | DCCCU11 | DCCCU12



Auxiliary contacts
1NO+1NC CODE D5LAU01
2NO+2NC CODE D5LAU02
I_e = 16 A (resistive loads)
4 A (inductive loads) at 250 Vac.



Safety key lock device
Simple CODE D5LCB11
Double CODE D5LCF11
For external handle, lock the handle by means of a key in position "OFF" (under request, in "ON"), the key can only be removed with the handle locked

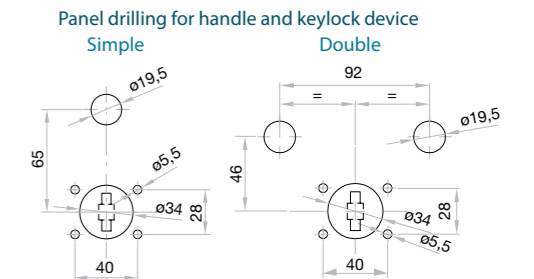

Dimensions (mm)

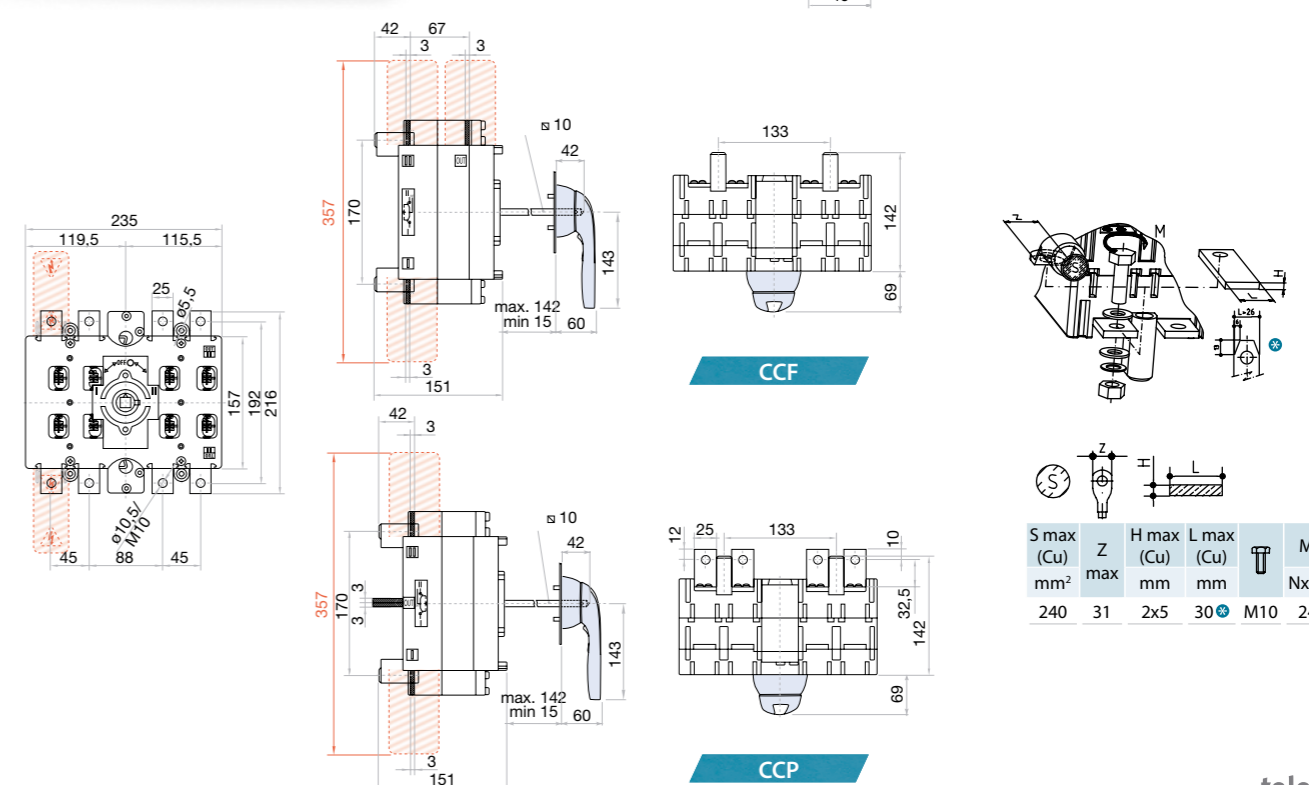

S max (Cu)	Z max	H max (Cu)	L max (Cu)	T	M
mm ²	mm	mm	mm	mm	Nxm
240	31	2x5	30	M10	24

CCF/CCP Changeover switch base mounting 3P - 3P+N

Size 2
A 500|630|800



Series	Poles	CODE-500A			CODE-630A			CODE-800A		
		3P	3P+N	NSO	3P	3P+N	NSO	3P	3P+N	NSO
CCF	3P	CCF05003PS0	CCF06303PS0	CCF08003PS0	CCF05003NS0	CCF06303NS0	CCF08003NS0			
	3P+N									
CCP	3P	CCP05003PS0	CCP06303PS0	CCP08003PS0	CCP05003NS0	CCP06303NS0	CCP08003NS0			
	3P+N									

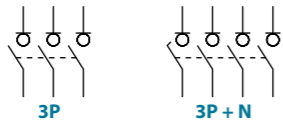

Technical information



According to IEC/EN 60947-3

		500			630			800		
Rated thermal current	I _{th} in ambient at 40° C	A	500	630	800					
Rated insulation voltage	U _i	V	1000	1000	1000					
Rated dielectric strength	50 Hz., 1 min.	V	8000	8000	8000					
Rated impulse withstand voltage	U _{imp}	kV	12	12	12					
AC Rated operational current ^{*(1)} (Rated operational frequency 50/60 Hz)	I _e	400V AC21A	A	500	630	800				
		400V AC22A	A	500	630	800 ^{*(5)}				
		500V AC21A	A	500	630	800				
		500V AC22A	A	500	630	800 ^{*(5)}				
		690V AC21A	A	500	630	800				
		690V AC22A	A	400	500	630 ^{*(5)}				
AC Rated operational power ^{*(2)}	P _e	3x400V AC23A	kW	200	250	315				
		3x500V AC23A	kW	156	197	250				
		3x690V AC23A	kW	173	216	272				

		500			630			800		
Rated capacitor power	400V, sen φ=0,65	kVAr	208	262	333					
Rated breaking capacity	400V AC22A	A	1500	1890	2400					
Rated making capacity	400V AC22A	A	1500	1890	2400					
Short - circuit behaviour										
Short - circuit making capacity ^{*(3)}	I _{cm}	kA (peak)	20	20	20					
Short - time withstand current (1 sec.)	I _{cw}	kA rms	13	13	13					
Minimum number of mechanical operations ^{*(4)}		Cycles	10000	10000	10000					
Minimum number of electrical operations	400V AC22A	Cycles	1000	1000	100 ^{*(5)}					
Maximum weight (3/4 poles)	CCF	Kg	11,5/12,6	11,5/12,6	11,9/13,2					
	CCP	Kg	12,8/14,3	12,8/14,3	13/14,6					

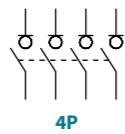

Also available 4P changeover switches under request, consult reference

^{*(1)} Other voltages and /or utilization categories; please consult
^{*(2)} Indicative values, value cos φ=0,8
^{*(3)} Without limiting protective device (short - circuit maintained 50 ms. - 100 ms.)
^{*(4)} Please consult us for more operations
^{*(5)} AC22B



Accessories



Direct handle
CODE DCCLI21

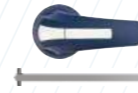

Panel handle included shaft ^{*(e1)}
IP65|UL50E/NEMA 250
Types: 1, 3R, 4, 4X y 12
CODE DCCLA21

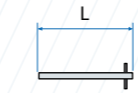

Shafts
Standard shaft included ^{*(e1)}
L (mm) | P (mm) |
195 | 195... 272 |

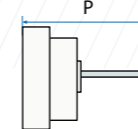

Shaft extensions
Type 1
L (mm) | P (mm) | CODE
336 | 195... 413 | DS-EP32
Type 2
L (mm) | P (mm) | CODE
535 | 195... 612 | DS-EP24



Rear protective plate
3P | 4P
DCCPP21 | DCCPP22



Terminal shrouds
Inputs
POS. I 3P | POS. II 3P | POS. I&II 3P+N | Common output 3P | 3P+N
DM2CU22 | DM2CU21 | DM2CU23 | DCCCU21 | DCCCU22



Auxiliary contacts
1NO+1NC CODE D5LAU01
2NO+2NC CODE D5LAU02
I_e = 16 A (resistive loads)
4 A (inductive loads) at 250 Vac.



Safety key lock device
Simple CODE D5LCB21
Double CODE D5LCF21
For external handle, lock the handle by means of a key in position "OFF" (under request, in "ON"), the key can only be removed with the handle locked

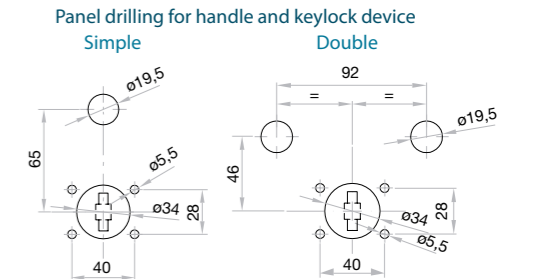

Dimensions (mm)

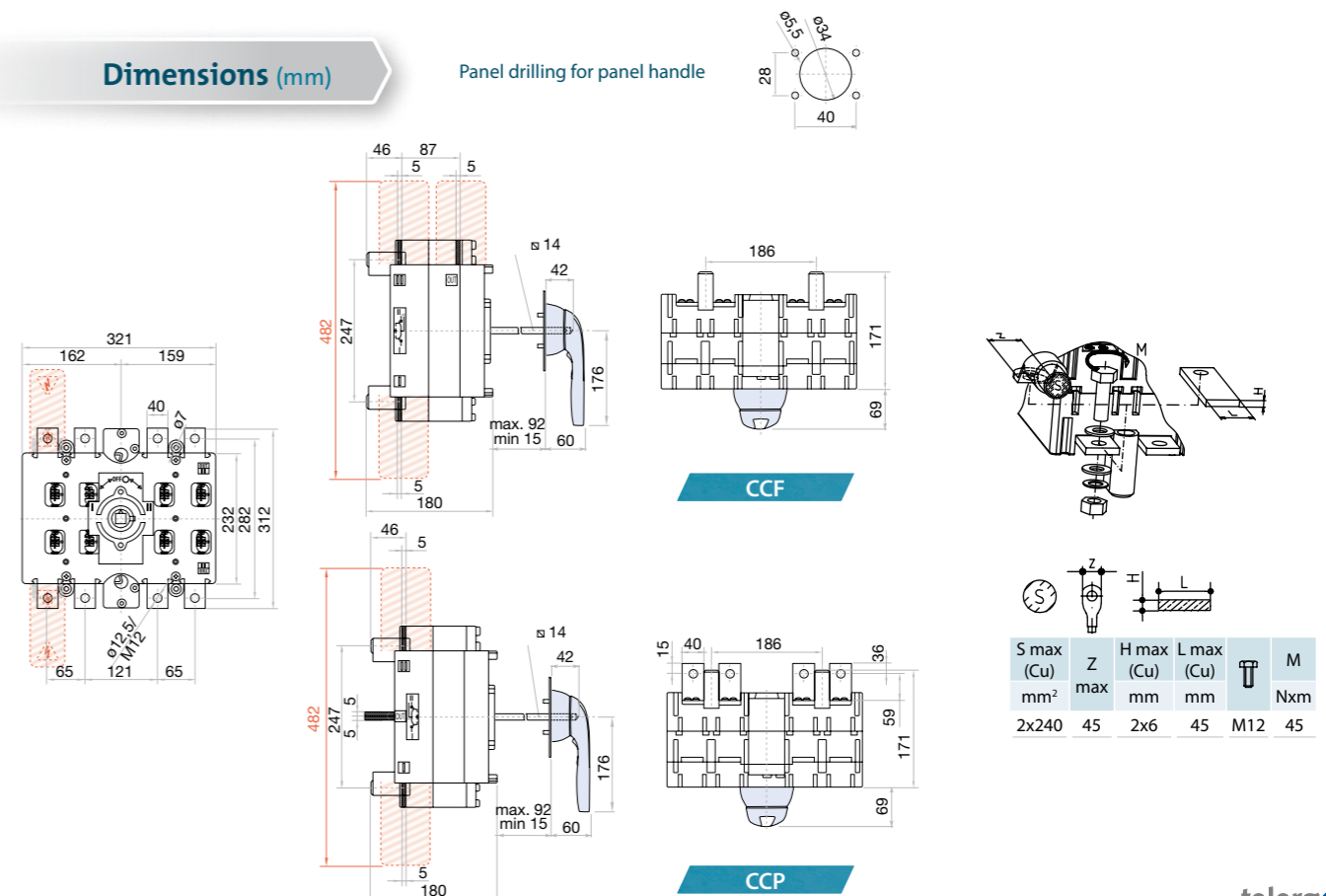

S max (Cu)	Z max	H max (Cu)	L max (Cu)	M
2x240	45	2x6	45	M12 45

CCF/CCP Changeover switch base mounting 3P - 3P+N

Size 3
A 1000|1250

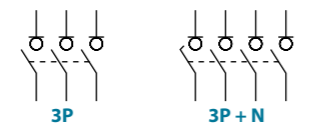
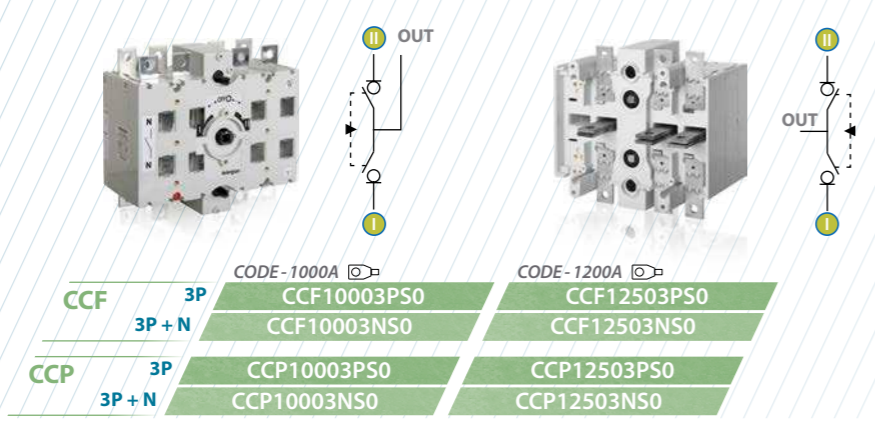

Technical information



According to IEC/EN 60947-3

		1000		1250	
Rated thermal current	I _{th} in ambient at 40° C	A	1000	1250	
Rated insulation voltage	U _i	V	1000	1000	
Rated dielectric strength	50 Hz., 1 min.	V	8000	8000	
Rated impulse withstand voltage	U _{imp}	kV	12	12	
AC Rated operational current ^{*(1)}	I _e	400V AC21A	A 1000	1250	
(Rated operational frequency 50/60 Hz)		400V AC22A	A 1000	1250 ^{*(5)}	
		500V AC21A	A 1000	1250	
		500V AC22A	A 1000	1250 ^{*(5)}	
		690V AC21A	A 1000	1250	
		690V AC22A	A 800	1000 ^{*(5)}	
AC Rated operational power ^{*(2)}	P _e	3x400V AC23A	kW 501	626	
		3x500V AC23A	kW 501	626	
		3x690V AC23A	kW 544	691	

		1000		1250	
Rated capacitor power	400V, sen φ=0,65	kVA	416	520	
Rated breaking capacity	400V AC22A	A	3000	3750	
Rated making capacity	400V AC22A	A	3000	3750	
Short - circuit behaviour					
Short - circuit making capacity ^{*(3)}	I _{cm}	kA (peak)	32	32	
Short - time withstand current (1 sec.)	I _{cw}	kA rms	25	25	
Minimum number of mechanical operations ^{*(4)}	Cycles		10000	10000	
Minimum number of electrical operations	400V AC22A	Cycles	500	100 ^{*(5)}	
Maximum weight (3/4 poles)	CCF	Kg	22,5 / 25	24,3 / 27,3	
	CCP	Kg	25 / 28,3	26 / 29,7	

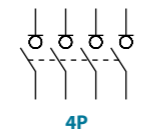

Also available 4P changeover switches under request, consult reference

^{*(1)} Other voltages and/or utilization categories; please consult
^{*(2)} Indicative values, value cos φ=0,8
^{*(3)} Without limiting protective device (short - circuit maintained 50 ms. - 100 ms.)
^{*(4)} Please consult us for more operations
^{*(5)} AC22B



Accessories



Direct handle
CODE DCCL131



Panel handle included shaft ^{*(e1)}
IP65/UL50E/NEMA 250
Types: 1, 3R, 4, 4X y 12
CODE DCCLA31

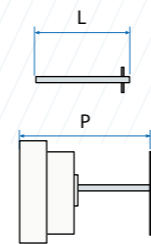

Shafts
Standard shaft included ^{*(e1)}
L (mm) | P (mm) |
186 | 223... 298 |
Shaft extensions
Type 1
L (mm) | P (mm) | CODE
336 | 223... 448 | DS-EP32
Type 2
L (mm) | P (mm) | CODE
535 | 223... 645 | DS-EP24



Rear protective plate
3P | 4P
DCCPP31 | DCCPP32



Terminal shrouds
Inputs | Common output
POS. I 3P | POS. II 3P | POS. I&II 3P+N | 3P | 3P+N
DM2CU32 | DM2CU31 | DM2CU33 | DCCCU31 | DCCCU32



Auxiliary contacts
1NO+1NC CODE D5LAU01
2NO+2NC CODE D5LAU02
I_e = 16 A (resistive loads)
4 A (inductive loads) at 250 Vac.



Safety key lock device
Simple CODE D5LCB31
Double CODE D5LCF31
For external handle, lock the handle by means of a key in position "OFF" (under request, in "ON"), the key can only be removed with the handle locked

Panel drilling for handle and keylock device
Simple | Double

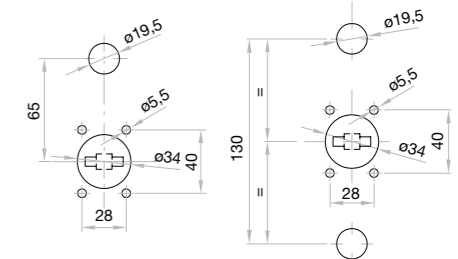

Dimensions (mm)

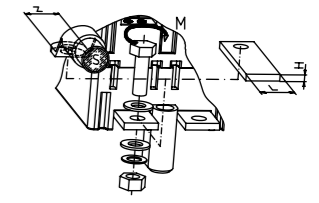
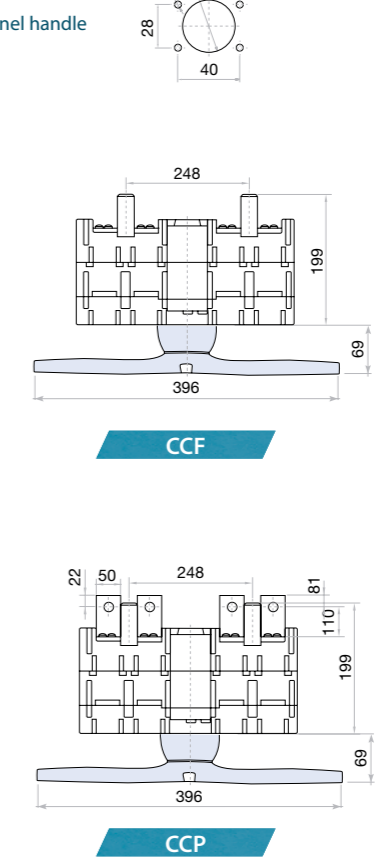
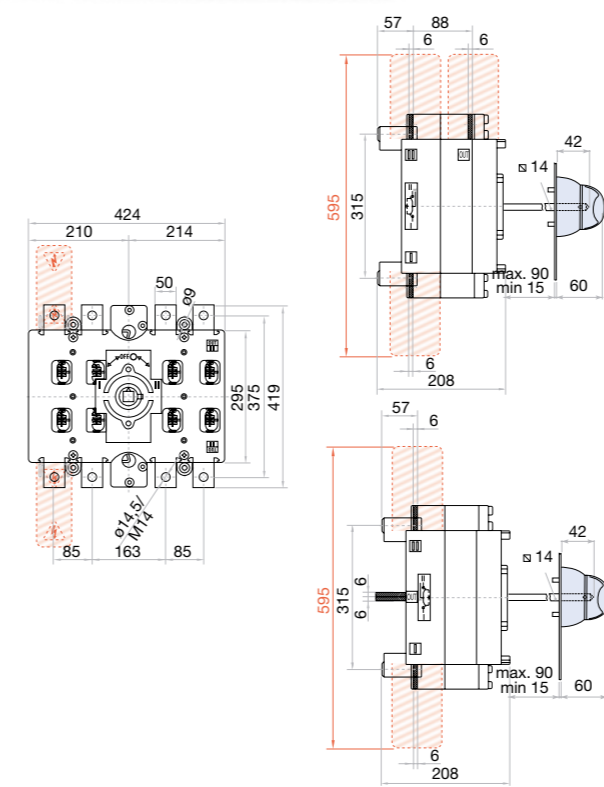

H max (Cu)	L max (Cu)	T	M
2x10	60	M14	55

S5000F Changeover switch base mounting 3P - 3P+N

Size 4
A 1600|1800|2000

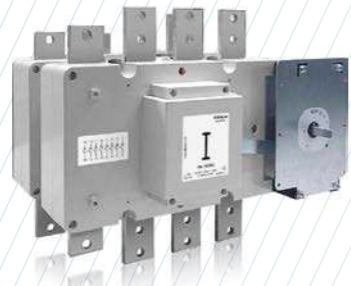

	CODE-1600A	CODE-1800A	CODE-2000A
3P	S5F16003PS0	S5F18003PS0	S5F20003PDO
3P+N	S5F16003NS0	S5F18003NS0	S5F20003ND0

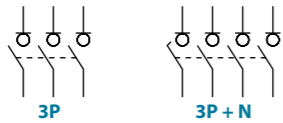

Technical information



According to IEC/EN 60947-3

		1600			1800			2000		
Rated thermal current	I _{th} in ambient at 40° C	A	1600	1800	2000					
Rated insulation voltage	U _i	V	1000	1000	1000					
Rated dielectric strength	50 Hz, 1 min.	V	10000	10000	10000					
Rated impulse withstand voltage	U _{imp}	kV	12	12	12					
AC Rated operational current ^{*(1)} (Rated operational frequency 50/60 Hz)	I _e	400V AC21A	A	1600	1800	2000				
		400V AC22A	A	1600	1800	2000				
		500V AC21A	A	1600	1800	2000				
		500V AC22A	A	1250	1600	1800				
		690V AC21A	A	1600	1800	1800				
AC Rated operational power ^{*(2)}	P _e	3x400V AC23A	kW	554,2	692,8	692,8				
		3x500V AC23A	kW	623,5	692,8	692,8				
		3x690V AC23A	kW	602,3	764,8	764,8				

		1600			1800			2000		
Rated capacitor power	400V, sen φ=0,65	kVAr	450,03	562,9	562,9					
Rated breaking capacity	400V AC22A	A	4800	5400	6000					
Rated making capacity	400V AC22A	A	4800	5400	6000					
Short - circuit behaviour										
Short - circuit making capacity ^{*(3)}	I _{cm}	kA (peak)	75	75	75					
Short - time withstand current (1 sec.)	I _{cw}	kA rms	50	50	50					
Minimum number of mechanical operations ^{*(4)}		Cycles	3000	3000	3000					
Minimum number of electrical operations	400V AC22A	Cycles	500	500	500					
Maximum weight (3/4 poles)		Kg	42,9/47,3	42,9/47,3	42,9/47,3					

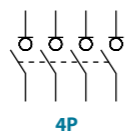

Also available 4P changeover switches under request, consult reference

^{*(1)} Other voltages and/or utilization categories; please consult
^{*(2)} Indicative values, value cos φ=0,8
^{*(3)} Without limiting protective device (short - circuit maintained 50 ms. - 100 ms.)
^{*(4)} Please consult us for more operations

Accessories



Direct handle
CODE D5LLI32



Panel handle included shaft ^{*(e1)}
IP65|UL50E/NEMA 250
Types: 1, 3R, 4, 4X y 12
CODE D5LLA31

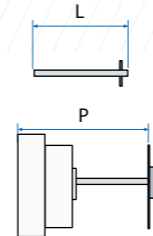

Shafts
Standard shaft included ^{*(e1)}
L (mm) P (mm)
239 418... 573
Shaft extensions
Consult



Terminal shrouds
CODE DS-CU41
(1 kit for input or output only front side)



Bridging links
CODE D5LPC42 (4 units)



Auxiliary contacts
1NO+1NC CODE DS-AU11
2NO+2NC CODE DS-AU12
I_e = 16 A (resistive loads)
4 A (inductive loads) at 250 Vac.



Safety key lock device
Simple CODE D5LCB41
Double CODE D5LCF41
For external handle, lock the handle by means of a key in position "OFF" (under request, in "ON"), the key can only be removed with the handle locked

Panel drilling for handle and keylock device

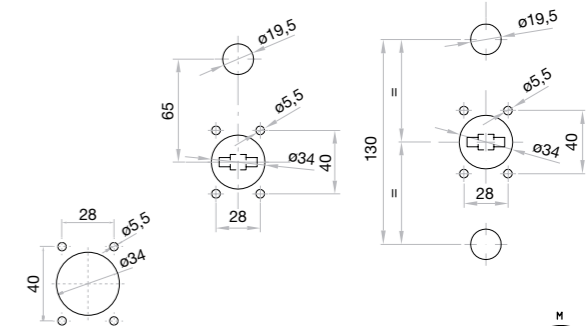

Dimensions (mm)

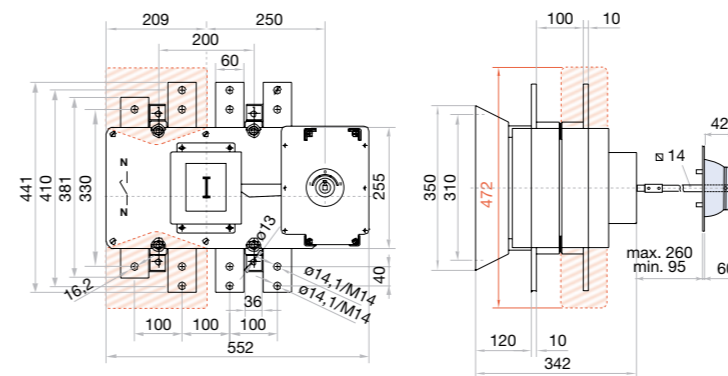

Panel drilling for panel handle

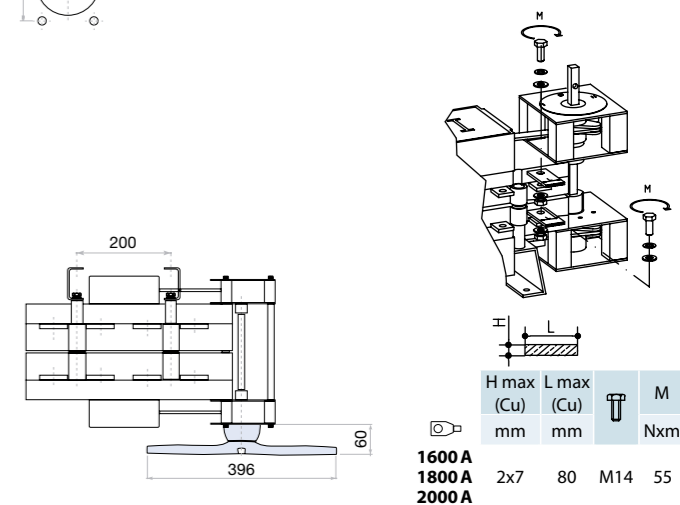

S5000F Changeover switch base mounting 3P - 3P+N

Size 5
A 2000|2500|3150

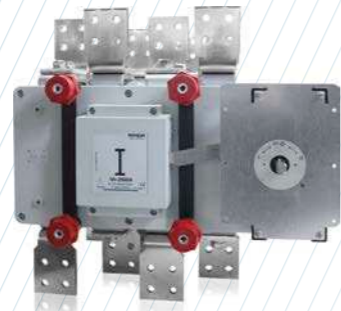

	CODE-2000A	CODE-2500A	CODE-3150A
3P	S5F20003PP0	S5F25003PP0	S5F31503PP0
3P + N	S5F20003NP0	S5F25003NP0	S5F31503NP0

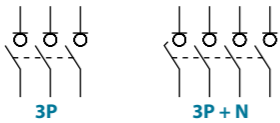

Technical information



According to IEC/EN 60947-3

		2000			2500			3150		
Rated thermal current	I _{th} in ambient at 40° C	A	2000	2500	3150					
Rated insulation voltage	U _i	V	1000	1000	1000					
Rated dielectric strength	50 Hz., 1 min.	V	10000	10000	10000					
Rated impulse withstand voltage	U _{imp}	kV	8	8	8					
AC Rated operational current ^{*(1)} (Rated operational frequency 50/60 Hz)	le	400V AC21A	A	2000	2500	3150				
		400V AC22A	A	2000	2500	2500 ^{*(5)}				
		500V AC21A	A	2000	2500	3150				
		500V AC22A	A	2000 ^{*(5)}	2000 ^{*(5)}	2200 ^{*(5)}				
		690V AC21A	A	2000	2500	2500				
	690V AC22A	A	2000 ^{*(5)}	2000 ^{*(5)}	2000 ^{*(5)}					
	800V AC20A	A	2000	2500	3150					
	1000V AC20A	A	2000	2500	3150					
AC Rated operational power ^{*(2)}	Pe	3x400V AC23A	kW	886,8	997,6	1108,5				
		3x500V AC23A	kW	866	1108,5	1108,5				
		3x690V AC23A	kW	956	956	956				

		2000			2500			3150		
Rated capacitor power	400V, sen φ=0,65	kVAr	720,5	810,5	900,6					
Rated breaking capacity	400V AC22A	A	6000	7500	9450					
Rated making capacity	400V AC22A	A	6000	7500	9450					
Short - circuit behaviour										
Short - circuit making capacity ^{*(3)}	I _{cm}	kA (peak)	100	100	100					
Short - time withstand current (1 sec.)	I _{cw}	kA rms	50	50	50					
Minimum number of mechanical operations ^{*(4)}	Cycles		2500	2500	2500					
Minimum number of electrical operations	400V AC22A	Cycles	500	500	500					
Maximum weight (3/4 poles)		Kg	Consult							

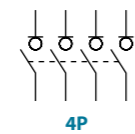

Also available 4P changeover switches under request, consult reference

^{*(1)} Other voltages and /or utilization categories; please consult
^{*(2)} Indicative values, value cos φ=0,8
^{*(3)} Without limiting protective device (short - circuit maintained 50 ms. - 100 ms.)
^{*(4)} Please consult us for more operations
^{*(5)} AC22B

Accessories



Direct handle (Slide bar)
CODE DS-EI61

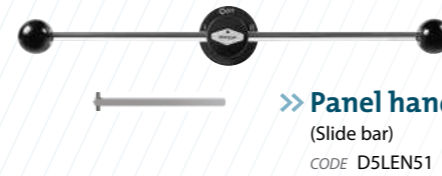

Panel handle (Slide bar) included shaft ^{*(e1)}
CODE D5LEN51

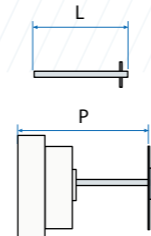

Shafts
Standard shaft included ^{*(e1)}
L (mm) P (mm)
333 788... 938
Shaft extensions
Consult



Auxiliary contacts
1NO+1NC CODE DS-AU11
2NO+2NC CODE DS-AU12
I_e = 16 A (resistive loads)
4 A (inductive loads) at 250 Vac.



Safety key lock device
Simple CODE D5LCB41
Double CODE D5LCF41
For external handle, lock the handle by means of a key in position "OFF" (under request, in "ON"), the key can only be removed with the handle locked

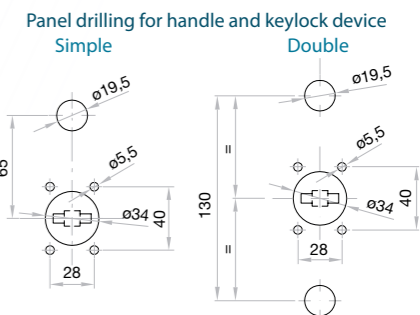

Dimensions (mm)

Panel drilling for panel handle

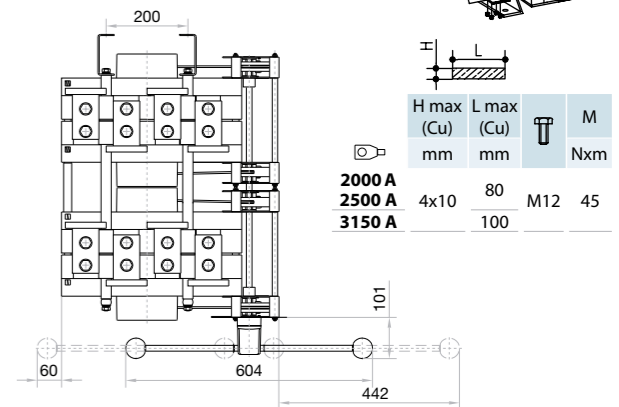
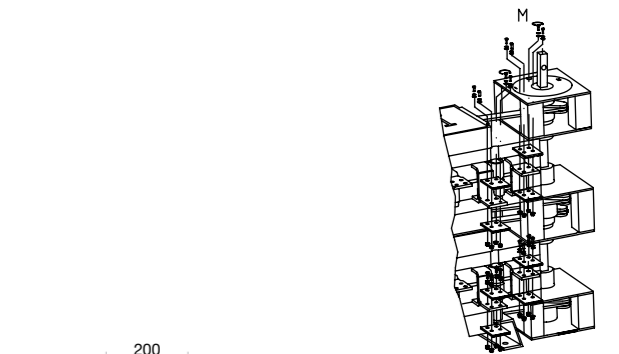
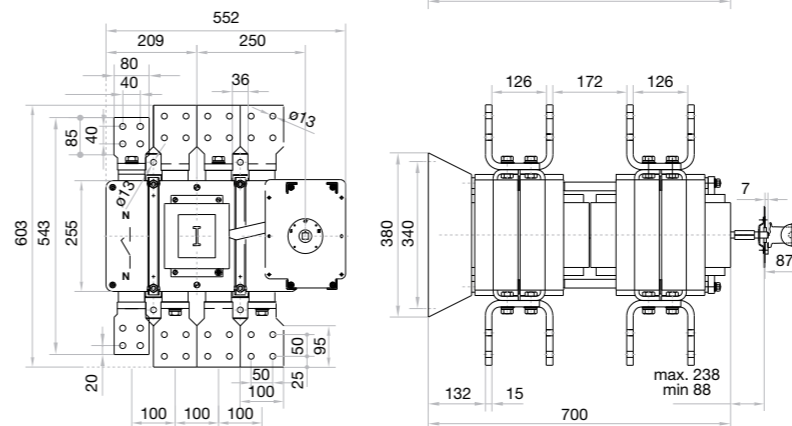
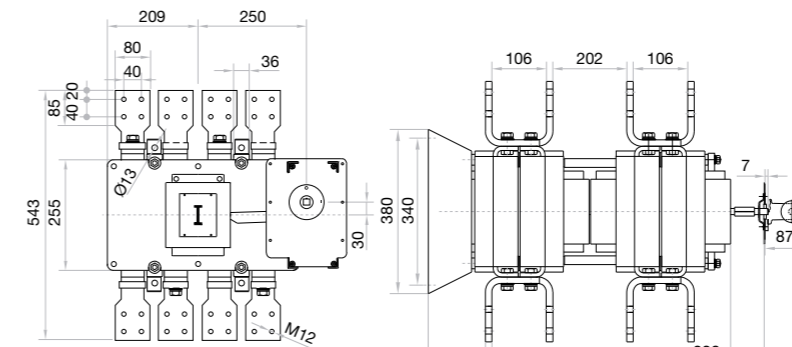
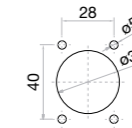

H max (Cu)	L max (Cu)	M
mm	mm	Nxm
2000 A	4x10	80 M12 45
2500 A		
3150 A		100

S5000B

By-pass changeover switch base mounting 3P - 3P+N

Size 0
A 125|160|200

	CODE-125A	CODE-160A	CODE-200A
3P	S5B01253PS0	S5B01603PS0	S5B02003PS0
3P + N	S5B01253NS0	S5B01603NS0	S5B02003NS0

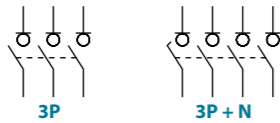
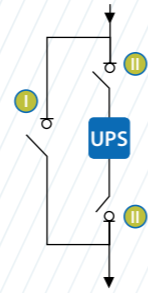

Technical information



According to IEC/EN 60947-3

		125			160			200		
Rated thermal current	I _{th} in ambient at 40° C	A	125	160	200					
Rated insulation voltage	U _i	V	1000	1000	1000					
Rated dielectric strength	50 Hz., 1 min.	V	4000	4000	4000					
Rated impulse withstand voltage	U _{imp}	kV	8	8	8					
AC Rated operational current ^{*(1)} (Rated operational frequency 50/60 Hz)	le 400V AC21A	A	125	160	200					
	400V AC22A	A	125	160	200					
	500V AC21A	A	125	160	200					
	500V AC22A	A	125	160	200					
	690V AC21A	A	125	160	180					
AC Rated operational power ^{*(2)}	Pe 3x400V AC23A	kW	69,2	88,6	88,6					
	3x500V AC23A	kW	69,2	88,6	88,6					
	3x690V AC23A	kW	76,4	76,4	76,4					

		125			160			200		
Rated capacitor power	400V, sen φ=0,65	kVAr	56,2	72	90					
Rated breaking capacity	400V AC22A	A	375	480	600					
Rated making capacity	400V AC22A	A	375	480	600					
Short - circuit behaviour										
Short - circuit making capacity ^{*(3)}	I _{cm}	kA (peak)	13	13	13					
Short - time withstand current (1 sec.)	I _{cw}	kA rms	7	7	7					
Minimum number of mechanical operations ^{*(4)}	Cycles		10000	10000	10000					
Minimum number of electrical operations	400V AC22A	Cycles	1000	1000	1000					
Maximum weight (3/4 poles)		Kg	2,4/2,8	2,4/2,8	2,5/2,9					

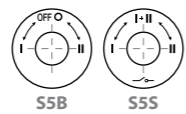

Overlapped contacts (S5S series), under request.

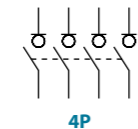

Also available 4P changeover switches under request, consult reference

^{*(1)} Other voltages and/or utilization categories; please consult
^{*(2)} Indicative values, value cos φ=0,8
^{*(3)} Without limiting protective device (short - circuit maintained 50 ms. - 100 ms.)
^{*(4)} Please consult us for more operations

Accessories



Direct handle
CODE D5LSI02



Terminal protection
CODE DS-CU01
(1 unit for input or output only front side)



Panel handle included shaft ^{*(e1)}
IP65
CODE D5LLA01



Safety key lock device
Simple CODE D5LCCB1
Double CODE D5LCCFB1

For external handle, lock the handle by means of a key in position "OFF" (under request, in "ON"), the key can only be removed with the handle locked

Panel drilling for handle and keylock device

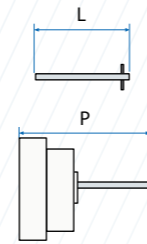
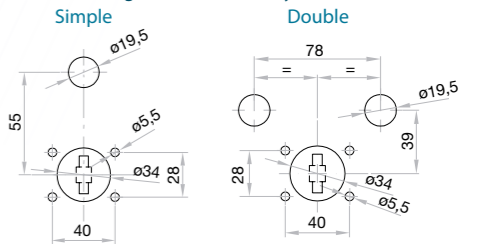

Shafts
Standard shaft included ^{*(e1)}
L (mm) | P (mm)
177 | 221... 346



Auxiliary contacts
1NO+1NC CODE DS-AU11
2NO+2NC CODE DS-AU12
I_e = 16 A (resistive loads)
4 A (inductive loads) at 250 Vac.

Dimensions (mm)

Panel drilling for panel handle

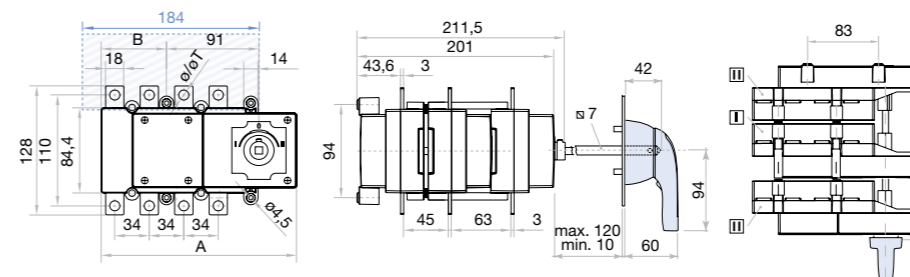
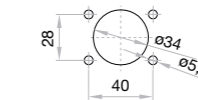

A	B	ø	S max (Cu)		H max (Cu)	L max (Cu)	M					
			mm ²	mm	mm	mm	Nxm					
125 A	160 A	3P	181	192	53	64	10	95	5	25	M8	13

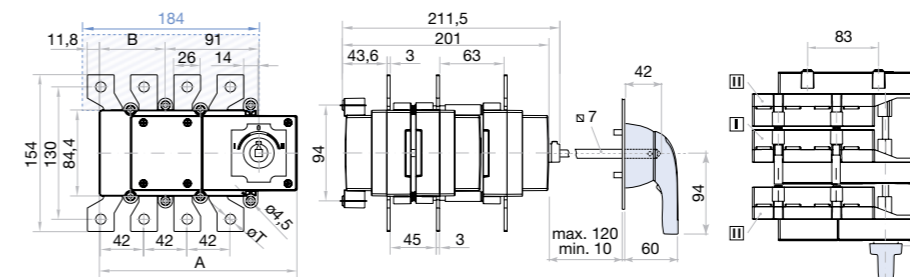

A	B	ø	S max (Cu)		Z max	H max (Cu)	L max (Cu)	M			
			mm ²	mm	mm	mm	mm	Nxm			
200 A	181	192	53	64	10	120	30	5	30	M10	18

S5000B By-pass changeover switch base mounting 3P - 3P+N

Size 1
A 250|315|400

	CODE-250A	CODE-315A	CODE-400A
3P	S5B02503PRO	S5B03153PRO	S5B04003PCO
3P + N	S5B02503NR0	S5B03153NR0	S5B04003NC0

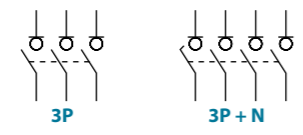
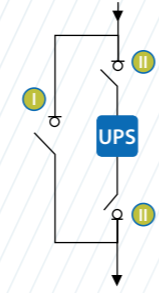
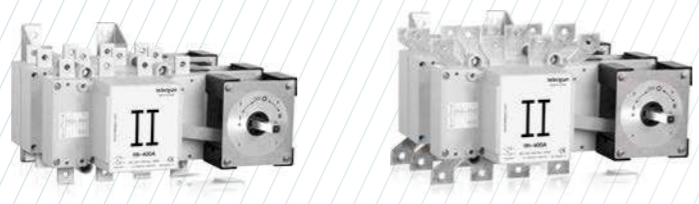

Accessories

- Direct handle**
CODE D5LLI12
- Panel handle** included shaft ^{*(e1)}
IP65|UL50E/NEMA 250
Types: 1, 3R, 4, 4X y 12
CODE D5LLA11
- Shafts**
Standard shaft included ^{*(e1)}
L (mm) | P (mm)
227 | 382... 516
- Auxiliary contacts**
1NO+1NC CODE DS-AU11
2NO+2NC CODE DS-AU12
Ie = 16 A (resistive loads)
4 A (inductive loads) at 250 Vac.
- Terminal protection**
CODE DS-CU12
(1 unit for input or output only front side)
- Terminal shrouds**
CODE DS-CU11
(1 kit for input or output only front side)
- Safety key lock device**
Simple CODE D5LSCB11
Double CODE D5LSCF11
For external handle, lock the handle by means of a key in position "OFF" (under request, in "ON"), the key can only be removed with the handle locked

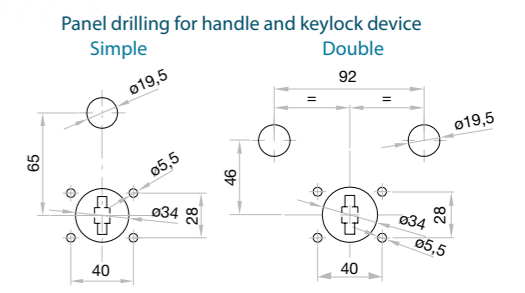

Technical information



According to IEC/EN 60947-3

		250			315			400		
Rated thermal current	I _{th} in ambient at 40° C	A	250	315	400					
Rated insulation voltage	U _i	V	1000	1000	1000					
Rated dielectric strength	50 Hz, 1 min.	V	5000	5000	5000					
Rated impulse withstand voltage	U _{imp}	kV	8	8	8					
AC Rated operational current ^{*(1)} (Rated operational frequency 50/60 Hz)	I _e	400V AC21A	A	250	315	400				
		400V AC22A	A	250	315	400				
		500V AC21A	A	250	315	400				
		500V AC22A	A	250	315	400				
		690V AC21A	A	200	250	250				
AC Rated operational power ^{*(2)}	P _e	3x400V AC23A	kW	138,5	174,5	221,7				
		3x500V AC23A	kW	138,5	173,2	218,2				
		3x690V AC23A	kW	152,9	152,9	152,9				

		250			315			400		
Rated capacitor power	400V, sen φ=0,65	kVA _r	112,5	141,8	180,1					
Rated breaking capacity	400V AC22A	A	750	945	1200					
Rated making capacity	400V AC22A	A	750	945	1200					
Short - circuit behaviour										
Short - circuit making capacity ^{*(3)}	I _{cm}	kA (peak)	20	20	20					
Short - time withstand current (1 sec.)	I _{cw}	kA rms	12	12	12					
Minimum number of mechanical operations ^{*(4)}		Cycles	10000	10000	10000					
Minimum number of electrical operations	400V AC22A	Cycles	1000	1000	1000					
Maximum weight (3/4 poles)		Kg	7,2/7,7	7,2/7,7	7,4/7,9					

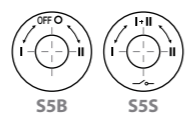

Overlapped contacts (S5S series), under request.

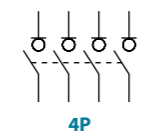

Also available 4P changeover switches under request, consult reference

Dimensions (mm)

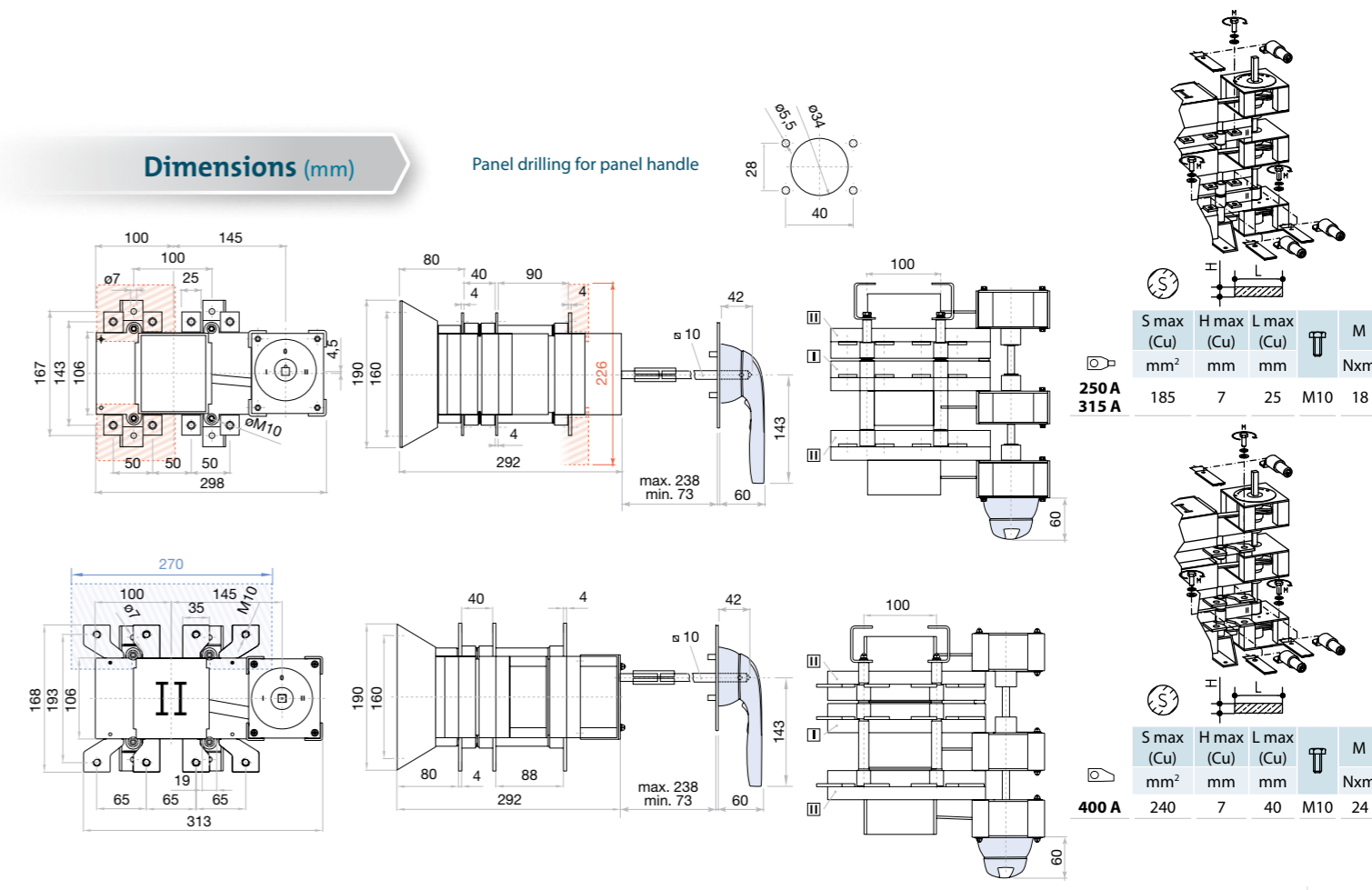

S max (Cu)	H max (Cu)	L max (Cu)	T	M
mm ²	mm	mm		Nxm
250 A	185	7	25	M10 18
315 A				

S max (Cu)	H max (Cu)	L max (Cu)	T	M
mm ²	mm	mm		Nxm
400 A	240	7	40	M10 24

S5000B

By-pass changeover switch base mounting 3P - 3P+N

Size 2
A 500|630

	CODE-500A	CODE-630A
3P	S5B05003PRO	S5B06303PRO
3P+N	S5B05003NR0	S5B06303NR0

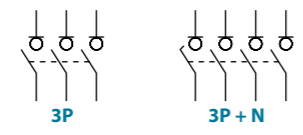
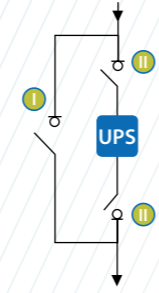
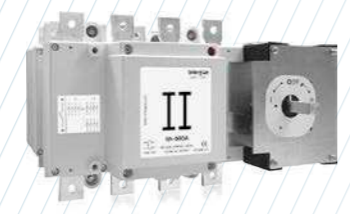

Accessories

- Direct handle**
 CODE D5LLI22
- Panel handle** included shaft ^{*(e1)}
 IP65|UL50E/NEMA 250
 Types: 1, 3R, 4, 4X y 12
 CODE D5LLA21
- Shafts**
Standard shaft included ^{*(e1)}
 L (mm) | P (mm)
 239 | 448... 613
- Auxiliary contacts**
 1NO+1NC CODE DS-AU11
 2NO+2NC CODE DS-AU12
 Ie = 16 A (resistive loads)
 4 A (inductive loads) at 250 Vac.
- Terminal shrouds**
 CODE DS-CU21
 (1 kit for input or output only front side)
- Safety key lock device**
 Simple CODE D5LCB21
 Double CODE D5LCF21
 For external handle, lock the handle by means of a key in position "OFF" (under request, in "ON"), the key can only be removed with the handle locked
 Panel drilling for handle and keylock device
 Simple | Double

Technical information



According to IEC/EN 60947-3

			500	630
Rated thermal current	I _{th} in ambient at 40° C	A	500	630
Rated insulation voltage	U _i	V	1000	1000
Rated dielectric strength	50 Hz., 1 min.	V	8000	8000
Rated impulse withstand voltage	U _{imp}	kV	12	12
AC Rated operational current ^{*(1)}	I _e	400V AC21A	A 500	630
(Rated operational frequency 50/60 Hz)		400V AC22A	A 500	630
		500V AC21A	A 500	630
		500V AC22A	A 500	630
		690V AC21A	A 500	630
		690V AC22A	A 400	500
		800V AC20A	A 500	630
		1000V AC20A	A 500	630
AC Rated operational power ^{*(2)}	P _e	3x400V AC23A	kW 277,1	349,1
		3x500V AC23A	kW 277,1	346,4
		3x690V AC23A	kW 239	301,1

			500	630
Rated capacitor power	400V, sen φ=0,65	kVAr	225,1	283,7
Rated breaking capacity	400V AC22A	A	1500	1890
Rated making capacity	400V AC22A	A	1500	1890
Short - circuit behaviour				
Short - circuit making capacity ^{*(3)}	I _{cm}	kA (peak)	26	26
Short - time withstand current (1 sec.)	I _{cw}	kA rms	16	16
Minimum number of mechanical operations ^{*(4)}	Cycles		10000	10000
Minimum number of electrical operations	400V AC22A	Cycles	1000	1000
Maximum weight (3/4 poles)		Kg	16,5/17,5	16,5/17,5

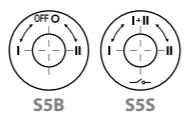

Overlapped contacts (S5S series), under request.

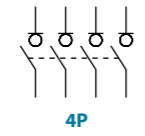

Also available 4P changeover switches under request, consult reference

tests:

Dimensions (mm)

Panel drilling for panel handle

S max (Cu)	H max (Cu)	L max (Cu)	T	M
mm ²	mm	mm		Nxm
500 A	2x185	6	40	M10 24
630 A	2x240	2x5	40	M10 24

^{*(1)} Other voltages and/or utilization categories; please consult
^{*(2)} Indicative values, value cos φ=0,8
^{*(3)} Without limiting protective device (short - circuit maintained 50 ms. - 100 ms.)
^{*(4)} Please consult us for more operations

S5000B

By-pass changeover switch base mounting 3P - 3P+N

Size 3
A 800|1000

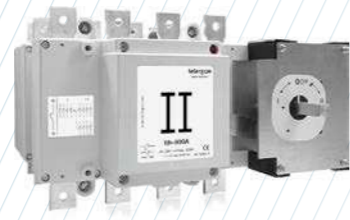

	CODE-800A	CODE-1000A
3P	S5B08003PRO	S5B10003PCO
3P+N	S5B08003NR0	S5B10003NC0

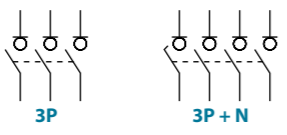
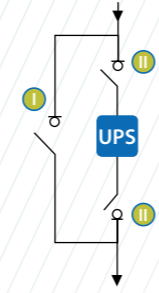

Technical information



According to IEC/EN 60947-3

			800	1000
Rated thermal current	I _{th} in ambient at 40° C	A	800	1000
Rated insulation voltage	U _i	V	1000	1000
Rated dielectric strength	50 Hz., 1 min.	V	8000	8000
Rated impulse withstand voltage	U _{imp}	kV	12	12
AC Rated operational current ^{*(1)} (Rated operational frequency 50/60 Hz)	I _e 400V AC21A	A	800	1000
	400V AC22A	A	800	1000
	500V AC21A	A	800	1000
	500V AC22A	A	800	1000
	690V AC21A	A	800	1000
	690V AC22A	A	630	800
	800V AC20A	A	800	1000
	1000V AC20A	A	800	1000
AC Rated operational power ^{*(2)}	P _e 3x400V AC23A	kW	443,4	501
	3x500V AC23A	kW	554,2	501
	3x690V AC23A	kW	239	544

			800	1000
Rated capacitor power	400V, sen φ=0,65	kVAr	360,2	450,3
Rated breaking capacity	400V AC22A	A	2400	3000
Rated making capacity	400V AC22A	A	2400	3000
Short - circuit behaviour				
Short - circuit making capacity ^{*(3)}	I _{cm} kA (peak)		60	60
Short - time withstand current (1 sec.)	I _{cw} kA rms		25	25
Minimum number of mechanical operations ^{*(4)}	Cycles		10000	10000
Minimum number of electrical operations	400V AC22A Cycles		500	500
Maximum weight (3/4 poles)	Kg		26,5/28,6	26,5/28,6

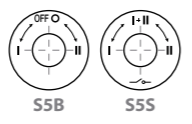

Overlapped contacts (S5S series), under request.

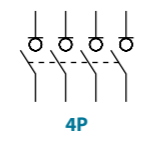

Also available 4P changeover switches under request, consult reference

^{*(1)} Other voltages and/or utilization categories; please consult
^{*(2)} Indicative values, value cos φ=0,8
^{*(3)} Without limiting protective device (short - circuit maintained 50 ms. - 100 ms.)
^{*(4)} Please consult us for more operations

Accessories



Direct handle
CODE D5LLI32



Panel handle included shaft ^{*(e1)}
IP65|UL50E/NEMA 250
Types: 1, 3R, 4, 4X y 12
CODE D5LLA31

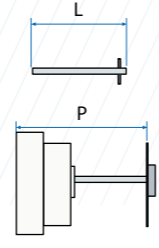

Shafts
Standard shaft included ^{*(e1)}
L (mm) | P (mm)
239 | 480... 645



Auxiliary contacts
1NO+1NC CODE DS-AU11
2NO+2NC CODE DS-AU12
I_e = 16 A (resistive loads)
4 A (inductive loads) at 250 Vac.



Terminal shrouds
CODE DS-CU31
(1 kit for input or output only front side)



Safety key lock device
Simple CODE D5LCB31
Double CODE D5LCF31
For external handle, lock the handle by means of a key in position "OFF" (under request, in "ON"), the key can only be removed with the handle locked

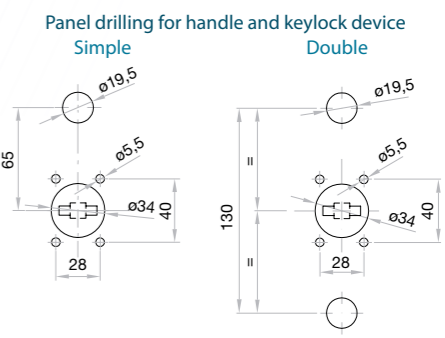

Dimensions (mm)

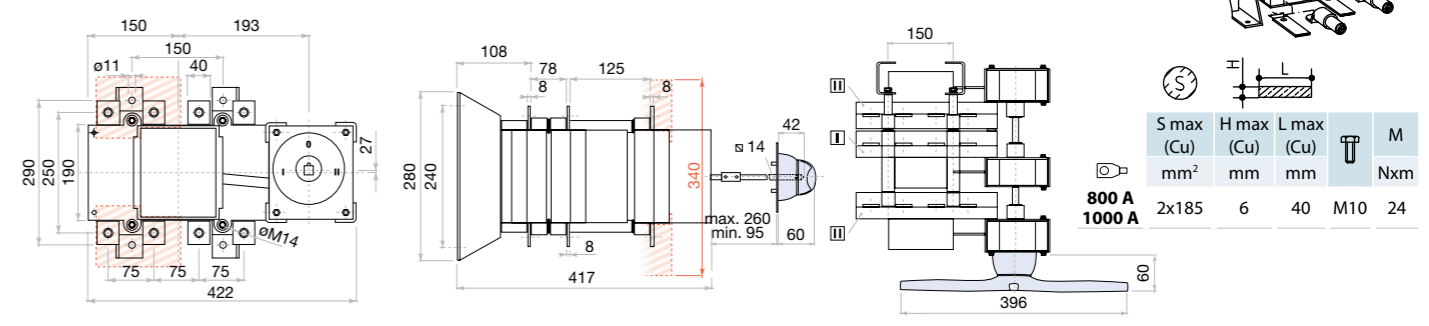

S max (Cu)	H max (Cu)	L max (Cu)	M
mm ²	mm	mm	Nxm
2x185	6	40	M10 24

S5000B

By-pass changeover switch base mounting 3P - 3P+N

Size 4
A 1250|1600|1800|2000

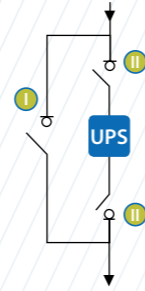
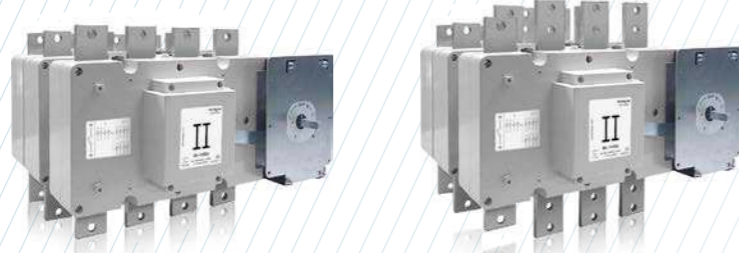

3P	CODE-1250A	CODE-1600A	CODE-1800A	CODE-2000A
	S5B12503PS0	S5B16003PS0	S5B18003PS0	S5B20003PD0
3P + N	S5B12503NS0	S5B16003NS0	S5B18003NS0	S5B20003ND0

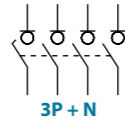
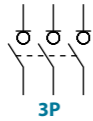

Accessories



Direct handle
CODE D5LLI32



Panel handle included shaft *(e1)
IP65|UL50E/NEMA 250
Types: 1, 3R, 4, 4X y 12
CODE D5LLA31

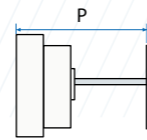
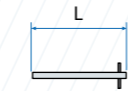

Shafts

Standard shaft included *(e1)
L (mm) | P (mm)
239 | 572... 645



Auxiliary contacts

1NO+1NC CODE DS-AU11
2NO+2NC CODE DS-AU12

Ie = 16 A (resistive loads)
4 A (inductive loads) at 250 Vac.



Terminal shrouds

CODE DS-CU41
(1 kit for input or output only front side)



Safety key lock device

Simple CODE D5LCB41
Double CODE D5LCF41

For external handle, lock the handle by means of a key in position "OFF" (under request, in "ON"), the key can only be removed with the handle locked

Panel drilling for handle and keylock device

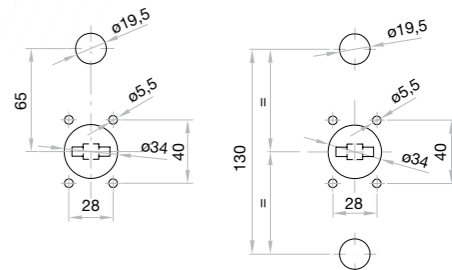

Technical information



According to IEC/EN 60947-3

		1250				1600				1800				2000							
Rated thermal current	I _{th} in ambient at 40° C	A				1250				1600				1800				2000			
Rated insulation voltage	U _i	V				1000				1000				1000				1000			
Rated dielectric strength	50 Hz., 1 min.	V				10000				10000				10000				10000			
Rated impulse withstand voltage	U _{imp}	kV				12				12				12				12			
AC Rated operational current *(1) (Rated operational frequency 50/60 Hz)	I _e 400V AC21A	A	1250	1600	1800	2000															
	400V AC22A	A	1250	1600	1800	2000															
	500V AC21A	A	1250	1600	1800	2000															
	500V AC22A	A	1000	1250	1600	1800															
	690V AC21A	A	1000	1600	1800	1800															
	690V AC22A	A	630	1000	1250	1600															
AC Rated operational power *(2)	Pe 3x400V AC23A	kW	554,2	554,2	692,8	692,8															
	3x500V AC23A	kW	554,2	623,5	692,8	692,8															
	3x690V AC23A	kW	478	602,3	764,8	764,8															

		1250				1600				1800				2000							
Rated capacitor power	400V, sen φ=0,65	kVAr				450,03				450,03				562,9				562,9			
Rated breaking capacity	400V AC22A	A				3750				4800				5400				6000			
Rated making capacity	400V AC22A	A				3750				4800				5400				6000			
Short - circuit behaviour																					
Short - circuit making capacity *(3)	I _{cm} kA (peak)	60				75				75				75							
Short - time withstand current (1 sec.)	I _{cw} kA rms	25				50				50				50							
Minimum number of mechanical operations *(4)	Cycles	3000				3000				3000				3000							
Minimum number of electrical operations	400V AC22A Cycles	500				500				500				500							
Maximum weight (3/4 poles)	Kg	65,2/72,1				65,2/72,1				65,2/72,1				65,2/72,1							

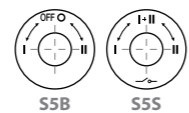

Overlapped contacts (S5S series), under request.

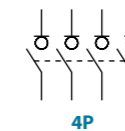

Also available 4P changeover switches under request, consult reference

Dimensions (mm)

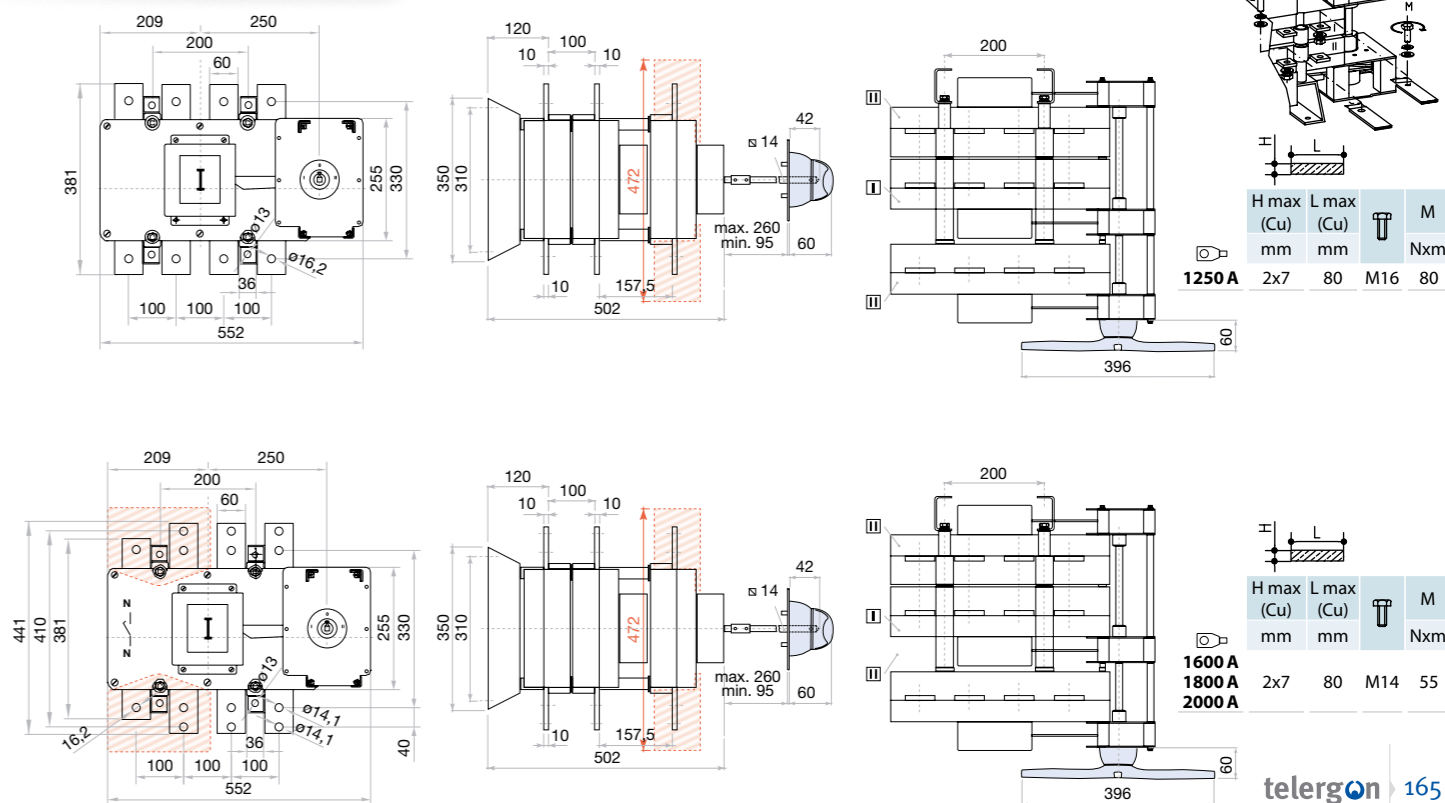

*(1) Other voltages and/or utilization categories; please consult
*(2) Indicative values, value cos φ=0,8
*(3) Without limiting protective device (short - circuit maintained 50 ms. - 100 ms.)
*(4) Please consult us for more operations

CTR₂ Metal enclosed transfer switch IP65

3P - 3P+N

Size 00
A 63|80



	CODE-63A	CODE-80A
3P	CTR2LC00633PB	CTR2LC00803PB
3P + N	CTR2LC00633NB	CTR2LC00803NB

Bridging links included

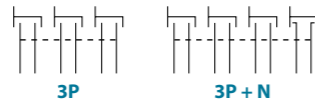

Accessories



>> **Panel handle** included
IP65



>> **Auxiliary contacts**
1NO+1NC CODE D5LAU01
2NO+2NC CODE D5LAU02
I_e = 16 A (resistive loads)
4 A (inductive loads) at 250 Vac.



>> **Bridging links** included
CODE D5LPCB1



>> **Safety key lock device**
Simple CODE D5LCBB1
Double CODE D5LCEB1

For external handle, lock the handle by means of a key in position "OFF" (under request, in "ON"), the key can only be removed with the handle locked

Technical information



According to IEC/EN 60947-3
IEC/EN 61439-1

			63	80
Rated thermal current	I _{th} in ambient at 40° C	A	63	80
Rated insulation voltage	U _i	V	800	800
Rated dielectric strength	50 Hz., 1 min.	V	3500	3500
Rated impulse withstand voltage	U _{imp}	kV	8	8
AC Rated operational current ^{*(1)} (Rated operational frequency 50/60 Hz)	I _e	400V AC21A A	63	80
		400V AC22A A	63	80
		500V AC21A A	63	80
		500V AC22A A	63	63
		690V AC21A A	63	63
	690V AC22A A	50	50	
AC Rated operational power ^{*(2)}	P _e	3x400V AC23A kW	34,9	34,9
		3x500V AC23A kW	34,6	34,6
		3x690V AC23A kW	30,5	30,5

			63	80
Rated capacitor power	400V, sen φ=0,65	kVAr	28,3	28,3
Rated breaking capacity	400V AC22A A	A	189	240
Rated making capacity	400V AC22A A	A	189	240
Short - circuit behaviour				
Short - circuit making capacity ^{*(3)}	I _{cm}	kA (peak)	5	5
Short - time withstand current (1 sec.)	I _{cw}	kA rms	3	3
Minimum number of mechanical operations ^{*(4)}		Cycles	10000	10000
Minimum number of electrical operations	400V AC22A	Cycles	1500	1500
Maximum weight (3/4 poles)		Kg	Consult	

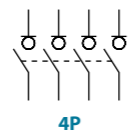

Also available 4P switches under request, consult reference

Dimensions (mm)

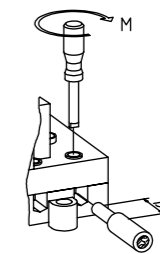
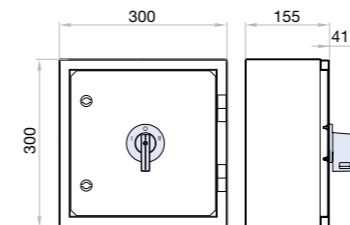

S max (Cu)	M
mm ²	Nxm
25	2



Standard supply

CTR₂ | CTRC Metal enclosed transfer switch IP65 3P - 3P+N

Size 0
A 125|160|200



	CODE-125A	CODE-160A	CODE-200A
CTR₂			
3P	CTR2FC01253PS	CTR2FC01603PS	CTR2FC02003PS
3P+N	CTR2FC01253NS	CTR2FC01603NS	CTR2FC02003NS
CTRC			
3P	CTRCFC01253PSAN	CTRCFC01603PSAN	CTRCFC02003PSAN
3P+N	CTRCFC01253NSAN	CTRCFC01603NSAN	CTRCFC02003NSAN

Bridging links included

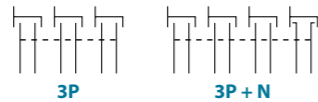

Technical information



According to IEC/EN 60947-3
IEC/EN 61439-1

			125	160	200
Rated thermal current	I _{th} in ambient at 40° C	A	125	160	200
Rated insulation voltage	U _i	V	1000	1000	1000
Rated dielectric strength	50 Hz, 1 min.	V	4000	4000	4000
Rated impulse withstand voltage	U _{imp}	kV	8	8	8
AC Rated operational current ^{*(1)} (Rated operational frequency 50/60 Hz)	le 400V AC21A	A	125	160	200
	400V AC22A	A	125	160	200
	500V AC21A	A	125	160	200
	500V AC22A	A	125	160	200
	690V AC21A	A	125	160	180
	690V AC22A	A	100	125	160
	800V AC20A	A	125	160	200
	1000V AC20A	A	125	160	200
AC Rated operational power ^{*(2)}	Pe 3x400V AC23A	kW	69,2	88,6	88,6
	3x500V AC23A	kW	69,2	88,6	88,6
	3x690V AC23A	kW	76,4	76,4	76,4

			125	160	200
Rated capacitor power	400V, sen φ=0,65	kVAr	56,2	72	72
Rated breaking capacity	400V AC22A	A	375	480	600
Rated making capacity	400V AC22A	A	375	480	600
Short - circuit behaviour					
Short - circuit making capacity ^{*(3)}	I _{cm}	kA (peak)	13	13	13
Short - time withstand current (1 sec.)	I _{cw}	kA rms	7	7	7
Minimum number of mechanical operations ^{*(4)}		Cycles	10000	10000	10000
Minimum number of electrical operations	400V AC22A	Cycles	1000	1000	1000
Maximum weight (3/4 poles)		Kg	Consult		

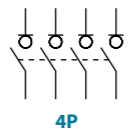

Also available 4P switches under request, consult reference

Accessories



Panel handle included IP65



Terminal protection
CODE DS-CU01
(1 unit for input or output)
CTR2



Auxiliary contacts
1NO+1NC CODE 55F DS-AU11
CODE D5LAU01
2NO+2NC CODE 55F DS-AU12
CODE D5LAU02



Bridging links included (4 pieces)
CODE D5LPC03

I_e = 16 A (resistive loads)
4 A (inductive loads) at 250 Vac.



Safety key lock device

Simple CODE D5LCBB1
Double CODE D5LCBB1

For external handle, lock the handle by means of a key in position "OFF" (under request, in "ON"), the key can only be removed with the handle locked

Dimensions (mm)

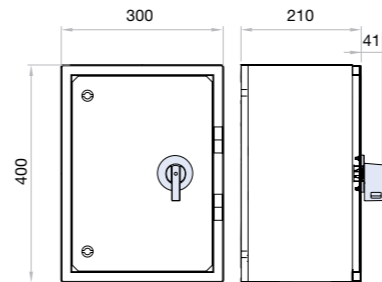

CTR₂

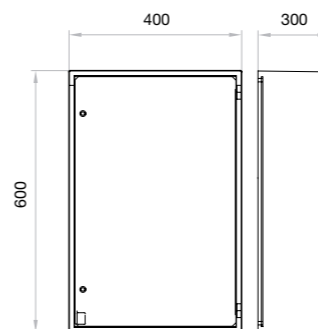

CTRC

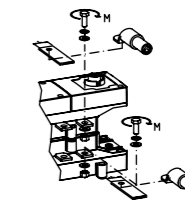

	ø	øT	S max (Cu) mm ²	H max (Cu) mm	L max (Cu) mm	T	M	Nxm
125 A	10	M8	95	5	25	M8	13	
160 A	10	M10	120	5	30	M10	18	



Standard supply CTR₂

^{*(1)} Other voltages and / or utilization categories. Please consult
^{*(2)} Indicative values, value cos φ=0,8
^{*(3)} Without limiting protective device (short-circuit maintained 50 ms. - 100 ms.)
^{*(4)} Please consult us for more operations



CTR₂ | CTRC Metal enclosed transfer switch IP65

3P - 3P+N

Size 1
A 200|250|315|400

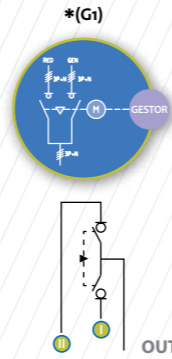

	CODE-200A	CODE-250A	CODE-315A	CODE-400A
CTR2 3P	-	CTR2CC02503PS	CTR2CC03153PS	CTR2CC04003PS
3P+N	-	CTR2CC02503NS	CTR2CC03153NS	CTR2CC04003NS
CTR2 3P	CTRCC02003PSAN	CTRCC02503PSAN	CTRCC03153PSAO	CTRCC04003PSAO
3P+N	CTRCC02003NSAN	CTRCC02503NSAN	CTRCC03153NSAO	CTRCC04003NSAO
with control module RGAM10 *(G1)	-	CTRCC02503PSAT	-	CTRCC04003PSAU
3P+N	-	CTRCC02503NSBA	-	CTRCC04003NSBB

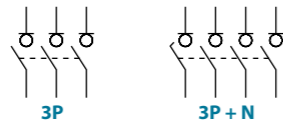

Technical information



According to IEC/EN 60947-3
IEC/EN 61439-1

			200	250	315	400
Rated thermal current	I _{th} in ambient at 40°C	A	200	250	315	400
Rated insulation voltage	U _i	V	1000	1000	1000	1000
Rated dielectric strength	50 Hz, 1 min.	V	6000	6000	6000	6000
Rated impulse withstand voltage	U _{imp}	kV	8	8	8	8
AC Rated operational current *(1)	I _e	400V AC21A A	200	250	315	400
(Rated operational frequency 50/60 Hz)		400V AC22A A	200	250	315	400
		500V AC21A A	200	250	315	400
		500V AC22A A	200	250	315*(5)	400*(5)
		690V AC21A A	200	250	315	400
		690V AC22A A	160	200	250	315*(5)
		800V AC20A A	200	250	315	400
		1000V AC20A A	200	250	315	400
AC Rated operational power *(2)	P _e	3x400V AC23A kW	80	90	100	125
		3x500V AC23A kW	78	94	100	125
		3x690V AC23A kW	69	86	108	138

			200	250	315	400
Rated capacitor power	400V, sen φ=0,65	kVAr	90	104	131	166
Rated breaking capacity	400V AC22A	A	600	750	945	1200
Rated making capacity	400V AC22A	A	600	750	945	1200
Short - circuit behaviour						
Short - circuit making capacity *(3)	I _{cm}	kA (peak)	12	12	12	12
Short - time withstand current (1 sec.)	I _{cw}	kA rms	8	8	8	8
Minimum number of mechanical operations *(4)		Cycles	10000	10000	10000	10000
Minimum number of electrical operations	400V AC22A	Cycles	1000	1000	1000	1000
Maximum weight (3/4 poles)		Kg	Consult			

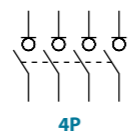

Also available 4P switches under request, consult reference

*(1) Other voltages and / or utilization categories. Please consult
*(2) Indicative values, value cos φ=0,8
*(3) Without limiting protective device (short-circuit maintained 50 ms. - 100 ms.)
*(4) Please consult us for more operations
*(5) AC22B



Accessories



Panel handle included
IP65 | UL50E/NEMA 250
Types: 1, 3R, 4, 4X y 12



Auxiliary contacts
1NO+1NC CODE D5LAU01
2NO+2NC CODE D5LAU02
I_e = 16 A (resistive loads)
4 A (inductive loads) at 250 Vac.



Terminal shrouds

POS. I	Inputs	POS. II	POS. I&II	Common output
3P	3P	3P+N	3P+N	3P 3P+N
DM2CU12	DM2CU11	DM2CU13	DCCCU11	DCCCU12



Safety key lock device

Simple CODE D5LCBB1
Double CODE D5LCBB1

For external handle, lock the handle by means of a key in position "OFF" (under request, in "ON"), the key can only be removed with the handle locked



RGAM10 control module *(G1)

- > 4 Digit alphanumeric LED display
- > 16 LEDs for displaying the states & measurements
- > Membrane keyboard with 6 keys
- > 4 Digital Inputs & 5 programmable relay outputs

Dimensions (mm)

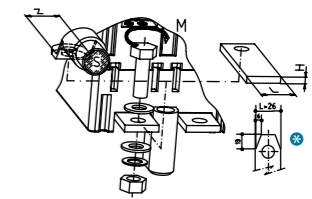
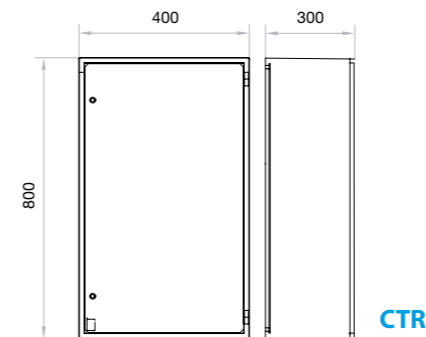
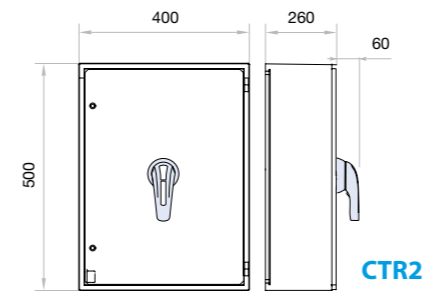

S max (Cu)	Z max	H max (Cu)	L max (Cu)	T	M
mm ²	mm	mm	mm		Nxm
240	31	2x5	30	M10	24

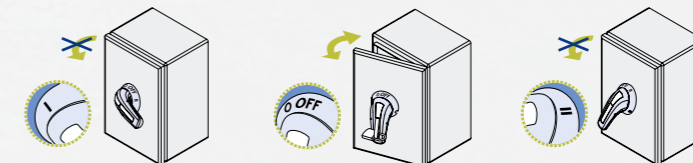

Standard supply CTR2

CTR₂ | CTRC Metal enclosed transfer switch IP65

3P - 3P+N

Size 2
A 500|630|800

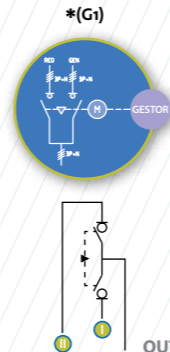
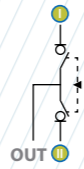
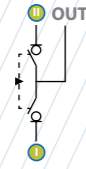

	CODE-500A	CODE-630A	CODE-800A
CTR ₂	3P	CTR2CC05003PS	CTR2CC06303PS
	3P+N	CTR2CC05003NS	CTR2CC06303NS
CTRc	3P	CTRCCC05003PSAO	CTRCCC06303PSAO
	3P+N	CTRCCC05003NSAO	CTRCCC06303NSAO
with control module RGAM10 ^{*(G1)}	3P	-	CTRCCC06303PSAU
	3P+N	-	CTRCCC06303NSBB

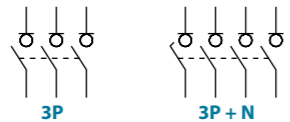

Accessories



Panel handle included
IP65 | UL50E/NEMA 250
Types: 1, 3R, 4, 4X y 12



Auxiliary contacts
1NO+1NC CODE D5LAU01
2NO+2NC CODE D5LAU02
I_e = 16 A (resistive loads)
4 A (inductive loads) at 250 Vac.



Terminal shrouds

POS. I	Inputs	POS. II	POS. I&II	Common output
3P	3P	3P+N	3P+N	3P 3P+N
DM2CU22	DM2CU21	DM2CU23	DCCCU21	DCCCU22



Safety key lock device

Simple CODE D5LCB21
Double CODE D5LCF21

For external handle, lock the handle by means of a key in position "OFF" (under request, in "ON"), the key can only be removed with the handle locked



RGAM10 control module ^{*(G1)}

- > 4 Digit alphanumeric LED display
- > 16 LEDs for displaying the states & measurements
- > Membrane keyboard with 6 keys
- > 4 Digital Inputs & 5 programmable relay outputs

Dimensions (mm)

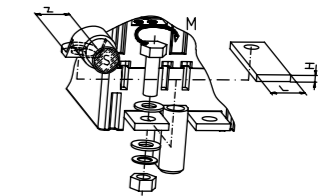
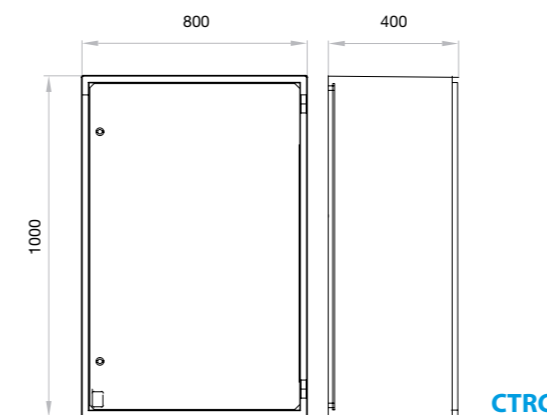
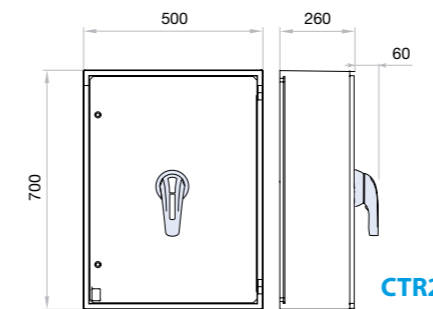

S max (Cu)	z max	H max (Cu)	L max (Cu)	T	M
2x240	45	2x6	45	M12	45

Technical information



According to IEC/EN 60947-3
IEC/EN 61439-1

			500	630	800
Rated thermal current	I _{th} in ambient at 40° C	A	500	630	800
Rated insulation voltage	U _i	V	1000	1000	1000
Rated dielectric strength	50 Hz., 1 min.	V	8000	8000	8000
Rated impulse withstand voltage	U _{imp}	kV	12	12	12
AC Rated operational current ^{*(1)} (Rated operational frequency 50/60 Hz)	400V AC21A	A	500	630	800
	400V AC22A	A	500	630	800 ^{*(5)}
	500V AC21A	A	500	630	800
	500V AC22A	A	500	630	800 ^{*(5)}
	690V AC21A	A	500	630	800
	690V AC22A	A	400	500	630 ^{*(5)}
AC Rated operational power ^{*(2)}	3x400V AC23A	kW	200	250	315
	3x500V AC23A	kW	156	197	250
	3x690V AC23A	kW	173	216	272

			500	630	800
Rated capacitor power	400V, sen φ=0,65	kVAr	208	262	333
Rated breaking capacity	400V AC22A	A	1500	1890	2400
Rated making capacity	400V AC22A	A	1500	1890	2400
Short - circuit behaviour					
Short - circuit making capacity ^{*(3)}	I _{cm}	kA (peak)	20	20	20
Short - time withstand current (1 sec.)	I _{cw}	kA rms	13	13	13
Minimum number of mechanical operations ^{*(4)}		Cycles	10000	10000	10000
Minimum number of electrical operations	400V AC22A	Cycles	1000	1000	100 ^{*(5)}
Maximum weight (3/4 poles)		Kg	Consult		

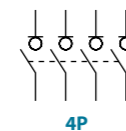

Also available 4P switches under request, consult reference

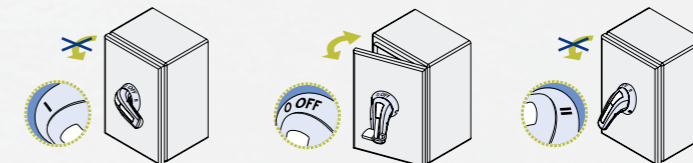

Standard supply CTR2

CTR₂ | CTRC Metal enclosed transfer switch IP65

3P - 3P+N

Size 3
A 1000|1250

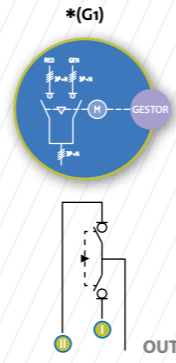
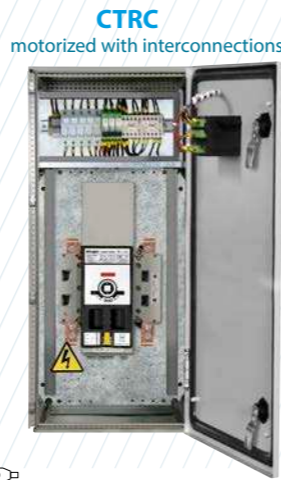

		CODE-1000A	CODE-1250A
CTR ₂	3P	CTR2CC10003PS	CTR2CC12503PS
	3P+N	CTR2CC10003NS	CTR2CC12503NS
CTR _C	3P	CTRCCC10003PSAP	CTRCCC12503PSAP
	3P+N	CTRCCC10003NSAP	CTRCCC12503NSAP
with control module RGK60 *(G1)	3P	CTRCCC10003PSAV	CTRCCC12503PSAV
	3P+N	CTRCCC10003NSBC	CTRCCC12503NSBC

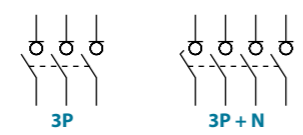

Technical information



According to IEC/EN 60947-3
IEC/EN 61439-1

			1000	1250	
Rated thermal current	I _{th} in ambient at 40° C	A	1000	1250	
Rated insulation voltage	U _i	V	1000	1000	
Rated dielectric strength	50 Hz., 1 min.	V	8000	8000	
Rated impulse withstand voltage	U _{imp}	kV	12	12	
AC Rated operational current *(1)	le	400V AC21A	A	1000	1250
		400V AC22A	A	1000	1250*(5)
		500V AC21A	A	1000	1250
		500V AC22A	A	1000	1250*(5)
		690V AC21A	A	1000	1250
		690V AC22A	A	800	1000*(5)
AC Rated operational power *(2)	Pe	3x400V AC23A	kW	501	626
		3x500V AC23A	kW	501	626
		3x690V AC23A	kW	544	691

			1000	1250
Rated capacitor power	400V, sen φ=0,65	kVAr	416	520
Rated breaking capacity	400V AC22A	A	3000	3750
Rated making capacity	400V AC22A	A	3000	3750
Short - circuit behaviour				
Short - circuit making capacity *(3)	I _{cm}	kA (peak)	32	32
Short - time withstand current (1 sec.)	I _{cw}	kA rms	25	25
Minimum number of mechanical operations *(4)		Cycles	3000	3000
Minimum number of electrical operations	400V AC22A	Cycles	500	100*(5)
Maximum weight (3/4 poles)		Kg	Consult	

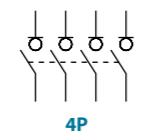

Also available 4P switches under request, consult reference

Accessories



Panel handle included
IP65 | UL50E/NEMA 250
Types: 1, 3R, 4, 4X y 12



Auxiliary contacts
1NO+1NC CODE D5LAU01
2NO+2NC CODE D5LAU02
I_e = 16 A (resistive loads)
4 A (inductive loads) at 250 Vac.



Terminal shrouds

POS. I	Inputs	POS. II	POS. I&II	Common output
3P	3P	3P+N	3P+N	3P 3P+N
DM2CU32	DM2CU31	DM2CU33	DCCCU31	DCCCU32

Safety key lock device

Simple CODE D5LCB31
Double CODE D5LCF31

For external handle, lock the handle by means of a key in position "OFF" (under request, in "ON"), the key can only be removed with the handle locked

RGK60 control module *(G1)

- Graphical display LCD
- 12 Digital Inputs & 7 programmable relay outputs
- 2 Expansion slots

Dimensions (mm)

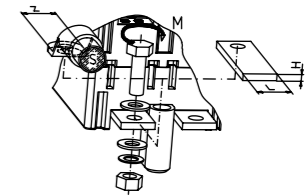
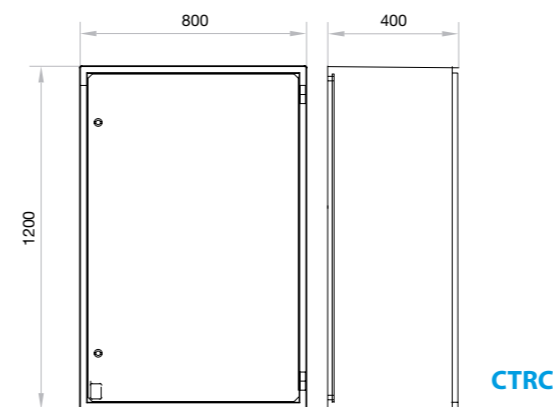
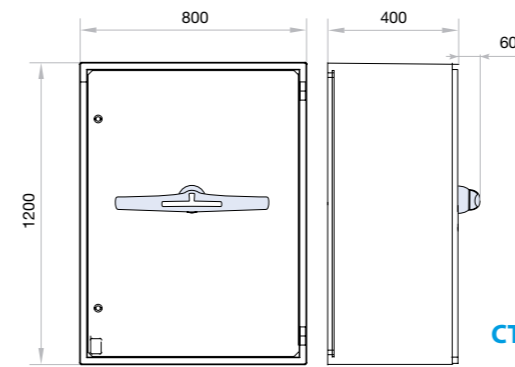

H max (Cu)	L max (Cu)	T	M
2x10	60	M14	55

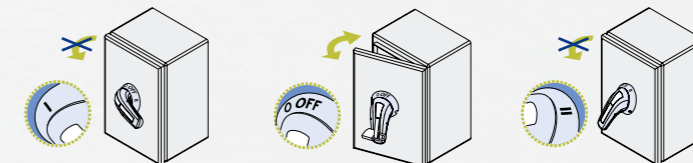

Standard supply CTR₂

*(1) Other voltages and / or utilization categories. Please consult
*(2) Indicative values, value cos φ=0,8
*(3) Without limiting protective device (short-circuit maintained 50 ms. - 100 ms.)
*(4) Please consult us for more operations
*(5) AC22B



CTR₂ | CTRC Metal enclosed transfer switch IP55- IP65 3P - 3P+N

Size 4
A 1600|1800

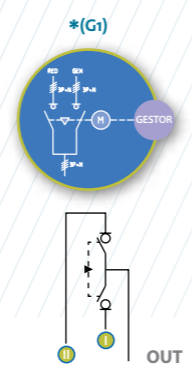

		CODE-1600A	CODE-1800A
CTR2	3P	CTR2FC16003PS	CTR2FC18003PS
	3P+N	CTR2FC16003NS	CTR2FC18003NS
CTRC	3P	CTRCFC16003PSAP	CTRCFC18003PSAP
	3P+N	CTRCFC16003NSAP	CTRCFC18003NSAP
with control module RGK60 *(G1)		CTRCFC16003PSAV	-
	3P+N	CTRCFC16003NSBC	-

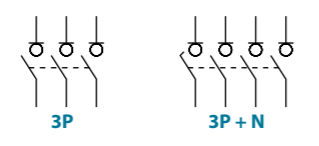

Technical information



According to IEC/EN 60947-3
IEC/EN 61439-1

			1600	1800	
Rated thermal current	I _{th} in ambient at 40° C	A	1600	1800	
Rated insulation voltage	U _i	V	1000	1000	
Rated dielectric strength	50 Hz., 1 min.	V	10000	10000	
Rated impulse withstand voltage	U _{imp}	kV	12	12	
AC Rated operational current *(1)	le	400V AC21A	A	1600	1800
		400V AC22A	A	1600	1800
		500V AC21A	A	1600	1800
		500V AC22A	A	1250	1600
		690V AC21A	A	1600	1800
		690V AC22A	A	1000	1250
AC Rated operational power *(2)	Pe	3x400V AC23A	kW	554,2	692,8
		3x500V AC23A	kW	623,5	692,8
		3x690V AC23A	kW	602,3	764,8

			1600	1800
Rated capacitor power	400V, sen φ=0,65	kVA	450,03	562,9
Rated breaking capacity	400V AC22A	A	4800	5400
Rated making capacity	400V AC22A	A	4800	5400
Short - circuit behaviour				
Short - circuit making capacity *(3)	I _{cm}	kA (peak)	75	75
Short - time withstand current (1 sec.)	I _{cw}	kA rms	50	50
Minimum number of mechanical operations *(4)		Cycles	3000	3000
Minimum number of electrical operations	400V AC22A	Cycles	500	500
Maximum weight (3/4 poles)		Kg	Consult	

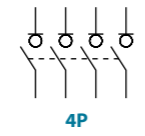

Also available 4P switches under request, consult reference



Accessories



>> Panel handle included
IP65|UL50E/NEMA 250
Types: 1, 3R, 4, 4X y 12



>> Auxiliary contacts
1NO+1NC CODE DS-AU11
2NO+2NC CODE DS-AU12
I_e = 16 A (resistive loads)
4 A (inductive loads) at 250 Vac.



>> Terminal shrouds
CODE DS-CU41
(1 kit for input or output only frontal side)



>> Bridging links
CODE D5LPC42 (4 units)



>> Safety key lock device
Simple CODE D5LCB41
Double CODE D5LCF41

For external handle, lock the handle by means of a key in position "OFF" (under request, in "ON"), the key can only be removed with the handle locked



>> RGK60 control module *(G1)
> Graphical display LCD
> 12 Digital Inputs & 7 programmable relay outputs
> 2 Expansion slots

Dimensions (mm)

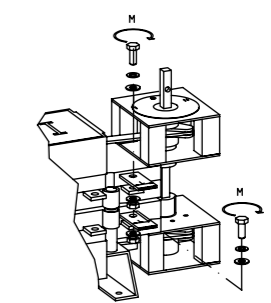
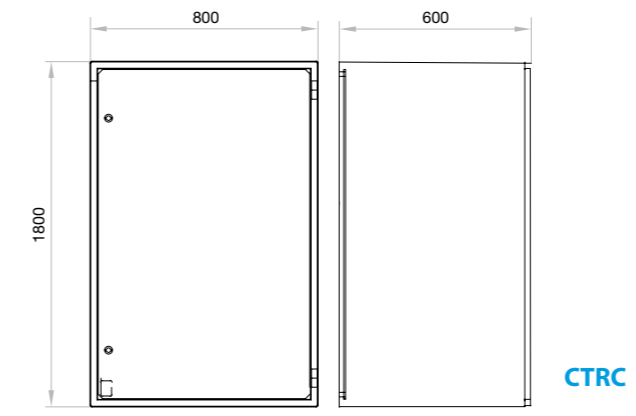
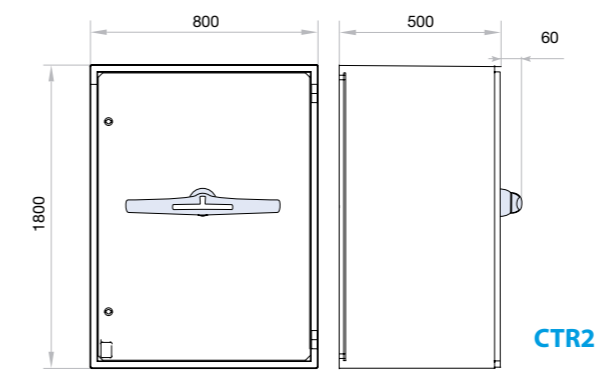

H max (Cu)	L max (Cu)	T	M
mm	mm		Nxm
2x7	80	M14	55

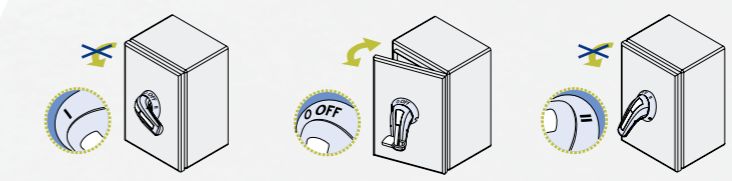

Standard supply CTR2

CTR₂ Metal enclosed transfer switch IP65

3P - 3P+N

Size 5
A 2000|2500|3150



	CODE-2000A	CODE-2500A	CODE-3150A
3P	CTR2FC20003PP	CTR2FC25003PP	CTR2FC31503PP
3P + N	CTR2FC20003NP	CTR2FC25003NP	CTR2FC31503NP

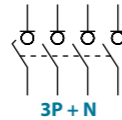
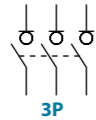

Technical information



According to IEC/EN 60947-3
IEC/EN 61439-1

		2000			2500			3150		
Rated thermal current	I _{th} in ambient at 40° C	A	2000	2500	3150					
Rated insulation voltage	U _i	V	1000	1000	1000					
Rated dielectric strength	50 Hz., 1 min.	V	10000	10000	10000					
Rated impulse withstand voltage	U _{imp}	kV	8	8	8					
AC Rated operational current ^{*(1)} (Rated operational frequency 50/60 Hz)	le	400V AC21A	A	2000	2500	3150				
		400V AC22A	A	2000	2500	2500 ^{*(5)}				
		500V AC21A	A	2000	2500	3150				
		500V AC22A	A	2000 ^{*(5)}	2000 ^{*(5)}	2200 ^{*(5)}				
		690V AC21A	A	2000	2500	2500				
	690V AC22A	A	2000 ^{*(5)}	2000 ^{*(5)}	2000 ^{*(5)}					
	800V AC20A	A	2000	2500	3150					
	1000V AC20A	A	2000	2500	3150					
AC Rated operational power ^{*(2)}	Pe	3x400V AC23A	kW	886,8	997,6	1108,5				
		3x500V AC23A	kW	866	1108,5	1108,5				
		3x690V AC23A	kW	956	956	956				

		2000			2500			3150		
Rated capacitor power	400V, sen φ=0,65	kVar	720,5	810,5	900,6					
Rated breaking capacity	400V AC22A	A	6000	7500	9450					
Rated making capacity	400V AC22A	A	6000	7500	9450					
Short - circuit behaviour										
Short - circuit making capacity ^{*(3)}	I _{cm}	kA (peak)	100	100	100					
Short - time withstand current (1 sec.)	I _{cw}	kA rms	50	50	50					
Minimum number of mechanical operations ^{*(4)}	Cycles		2500	2500	2500					
Minimum number of electrical operations	400V AC22A	Cycles	500	500	500					
Maximum weight (3/4 poles)		Kg	Consult							

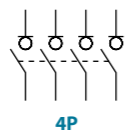

Also available 4P switches under request, consult reference

^{*(1)} Other voltages and / or utilization categories. Please consult
^{*(2)} Indicative values, value cos φ=0,8
^{*(3)} Without limiting protective device (short-circuit maintained 50 ms. - 100 ms.)
^{*(4)} Please consult us for more operations
^{*(5)} AC22B

Accessories



Panel handle included (Slider bar)



Terminal shrouds
CODE DS-CU41 (1 kit for input or output only frontal side)



Auxiliary contacts
1NO+1NC CODE DS-AU11
2NO+2NC CODE DS-AU12
I_e = 16 A (resistive loads)
4 A (inductive loads) at 250 Vac.



Safety key lock device
Simple CODE D5LCB41
Double CODE D5LCF41

For external handle, lock the handle by means of a key in position "OFF" (under request, in "ON"), the key can only be removed with the handle locked

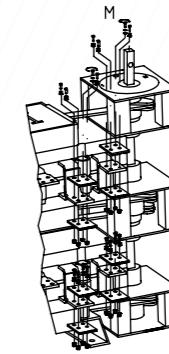

	H max (Cu) mm	L max (Cu) mm	M	M
2000 A	4x10	80	M12	45
2500 A				
3150 A				

Dimensions (mm)

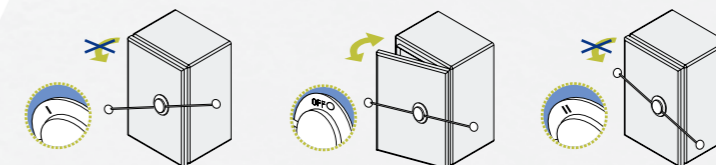
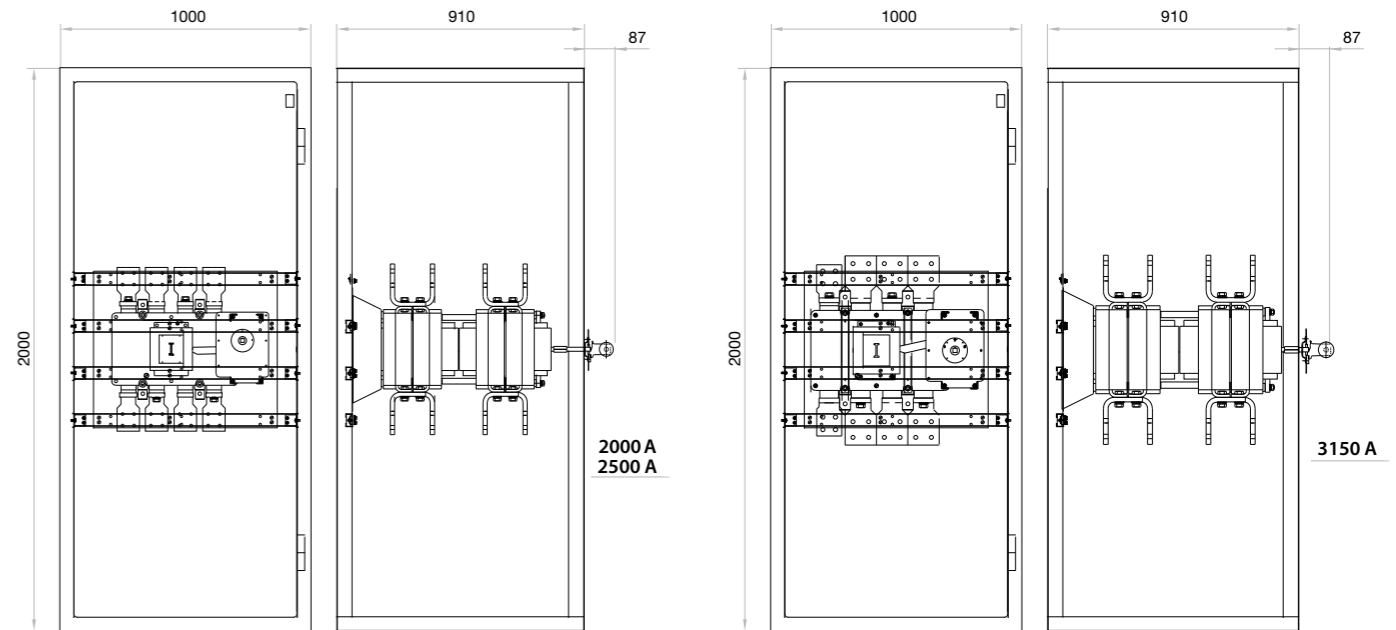

Standard supply

Kit motorized unit for switch or changeover switch

Motorized units to automate the drive system of the switch-disconnectors and changeover switches, with a high level of reliability, safety and ease of operation even in extreme situations.

series
UM

According to:
IEC/EN 60947-1 y 3
IEC/EN/UNE 61000-6, parts 2 y 4
RoHS

Testing and approvals:



The motorized unit kits are manufactured with high safety self-extinguishing materials, providing an excellent level of electrical insulation, low smoke emission and high resistance to electromechanical stress.

They comply with environmental requirements and undergo strict quality controls for a reliable product that meets the most demanding requirements.

They consist of a body housing the motor, gears, electronics to command and control. They are equipped with a selector for automatic-manual-lock operating modes.

The kit concept simplifies both logistics and maintenance, for easy and simple assembly on the changeover switch or switch - disconnector as required.

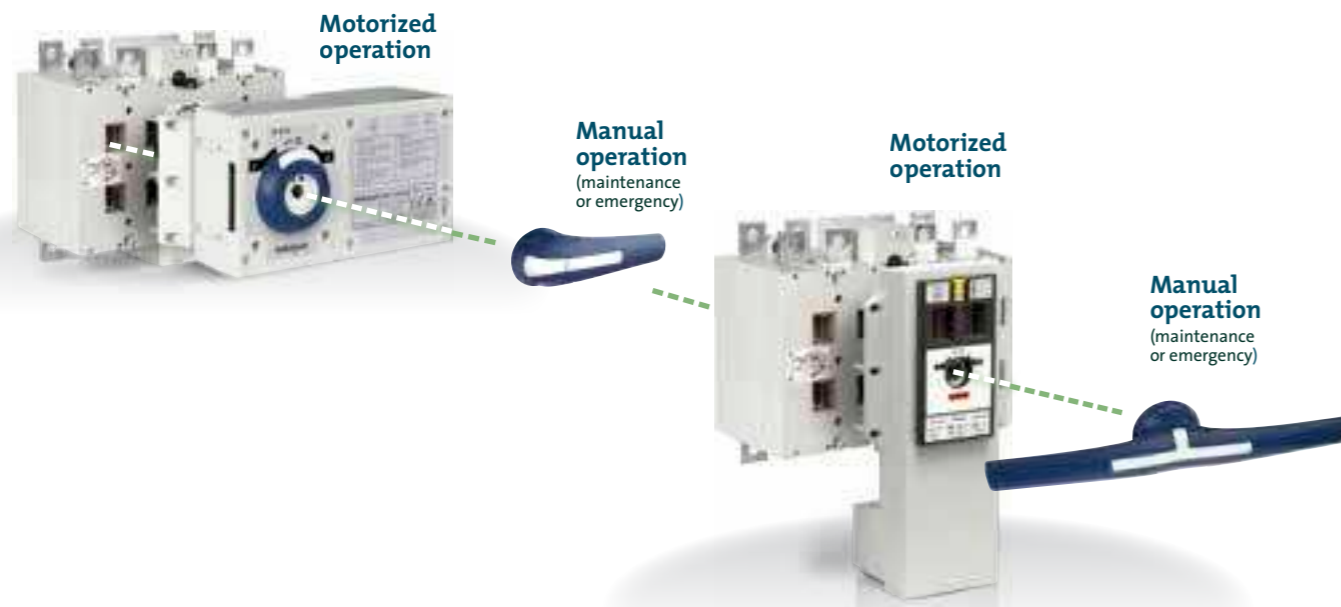

- > IEC/EN 60947-1 and 3. Low voltage devices. General part and switch - disconnectors.
- > IEC/EN/UNE 61000-6, Parts 2 and 4. Electromagnetic compatibility in industrial environments, immunity and emission.

- > According to European Standard 2006/95/CE for low voltage.
- > According to European standard 2004/108/CE of EMC.

series
UM-S



1 2 3 4 5 6
U M S

Supply voltage
230Vac/dc.
For switch - disconnectors
S5 & S6 sizes 1 and 2.

series
UM-C



1 2 3 4 5 6
U M C

Supply voltage
230Vac/dc.
For changeover switches
S5F & CCF sizes 0 and 1.

series
UM-S



1 2 3 4 5 6
U M S

Supply voltage
120 - 230 - 277Vac/dc.
For switch - disconnectors
S5 sizes 3 up to 5.

series
UM-C



1 2 3 4 5 6
U M C

Supply voltage
120 - 230 - 277Vac/dc.
For changeover switches
S5F & CCF sizes 2 up to 4.

UM-S Motorized unit kit for switch S5000 & S6000

series
UM-S

series
UM-S



	120 Vac/dc	230 Vac/dc	277 Vac/dc
Size 3 UM T2	UM-S21120Z	UM-S21230Z	UM-S21277Z
Size 3^(m1) UM T3	UM-S32120Z	UM-S32230Z	UM-S32277Z
S5 Size 4 UM T3	UM-S31120Z	UM-S31230Z	UM-S31277Z
Size 5 UM T3	UM-S32120Z	UM-S32230Z	UM-S32277Z

^(m1) For 2000A size 3.

S5 S6	Size 1 UM T0	230 Vac/dc
	Size 2 UM T0	UM-S1A230Z
		UM-S2A230Z

Dimensions (mm)

UM T0

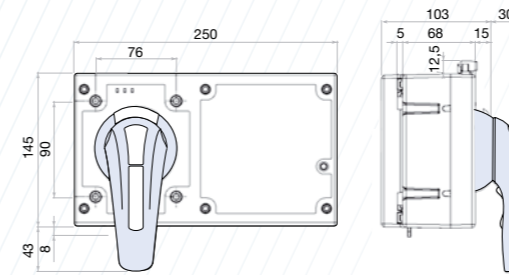

S5000 size 1&2 + UM T0

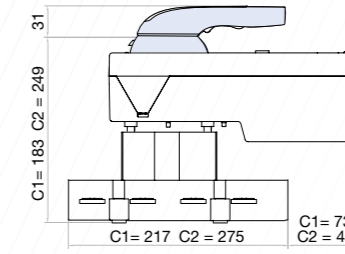

S6000 size 1&2 + UM T0

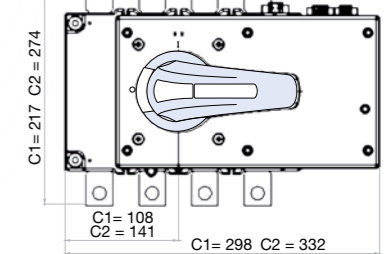
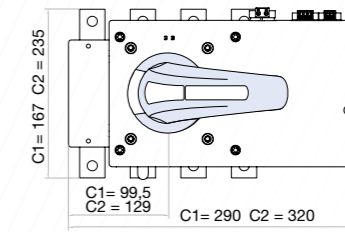
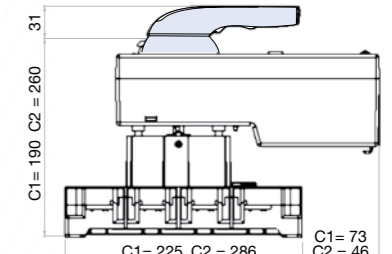

UM T2 - T3

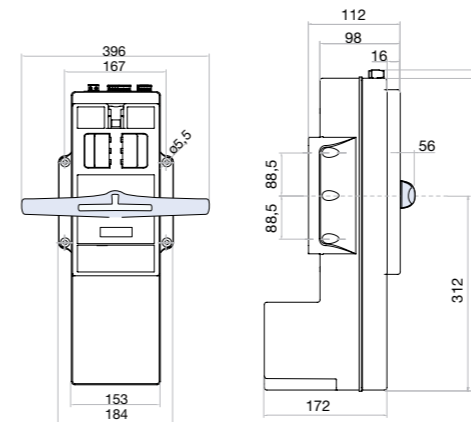

S5000 size 3 (2000A) + UMT3

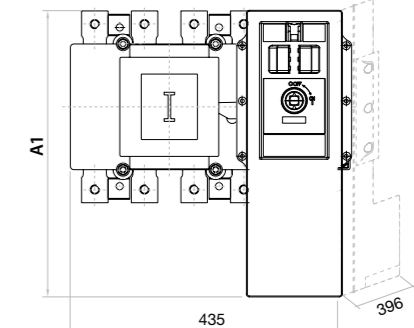

Technical information



According to IEC / EN 60947-3

Rated operational voltage	230Vac/dc	
Frequency	Hz	50/60
Operating voltage range (based in our own tests) (S5 S6 size 1)	ΔV	0,85*V to 1,15*V
Operating voltage range (based in our own tests) (S5 S6 size 2)	ΔV	0,85*V to 1,10*V
Operating voltage range according to IEC/EN 60947-6	ΔV	0,95*V to 1,10*V
Cable of voltage supply	mm ²	1,5 - 2,5
Cable section area Input Signals	mm ²	0,5 - 1,5
Cable section area Auto-Lock mode Outputs	mm ²	0,5 - 1,5
Inrush Current	A	1,1
Use current (I _{rms})	mA	45
Use current (I _{max})	mA	137
Protective Fuse (Ref. F1AL250V Littelfuse)	A	1
Operating angle		0-90° (0 - I)
Number of UM T0 operations (S5 S6 size 1)	Cycles	10000
Number of UM T0 operations (S5 S6 size 2)	Cycles	5000
Operation speed (0-I-0) (S5 S6 size 1)	Cycles/hour	120
Operation speed (0-I-0) (S5 S6 size 2) ^(*)	Cycles/hour	60/120
Operating temperature	RH90%	- 25°C + 55°C
Transportation and storage temperature	RH90%	- 40°C + 70°C
Weight	Kg	1,8

Pos.	Direction	Pos.	Operating time
0	→	I	0,75 sec
I	→	0	0,75 sec

Rated operational voltage	120Vac/dc	230Vac/dc	277Vac/dc
Frequency	Hz	50/60	
Operating voltage range (based in our own tests)	ΔV	0,85*V to 1,15*V	
Operating voltage range according to IEC/EN 60947-6	ΔV	0,95*V to 1,10*V	
Cable of voltage supply	mm ²	1,5 - 2,5	
Cable section area Input & MODBUS Signals	mm ²	0,5 - 1,5	
Cable section area Outputs	mm ²	0,5 - 1,5	
Inrush Current	A	17	
Nominal Current during operation UM T2	A	4,75	2,5
Nominal Current during operation UM T3	A	7,5	3,9
Use current (I _{rms})	A	0,041	
Use current (I _{max})	A	0,275	
Contacts operating time	ms	180	174
Number of UM T2 operations for S5 size 3 1000 - 1250A ^(*) ^(*)	Cycles	3000 / 10000	
Operation rate (0-I-0) for S5 size 3 1000 - 1250A ^(*)	Cycles/hour	20 / 120	
Number of UM T3 operations for S5 size 3 2000A ^(*) ^(*)	Cycles	3000 / 6000	
Operation rate (0-I-0) for S5 size 3 2000A ^(*)	Cycles/hour	20 / 40	
Number of UM T3 operations for S5 size 4 1000 - 2000A ^(*) ^(*)	Cycles	3000 / 6000	
Operation rate (0-I-0) for S5 size 4 1000 - 2000A ^(*)	Cycles/hour	20 / 40	
Number of UM T3 operations for S5 size 5 2000 - 3150A ^(*) ^(*)	Cycles	3000 / 6000	
Operation rate (0-I-0) for S5 size 5 2000 - 3150A ^(*)	Cycles/hour	20 / 40	
Operating temperature	T/Un RH90%	- 25°C + 55°C	
Transportation and storage temperature	RH90%	- 40°C + 70°C	
Weight T2/T3	Kg	3,96 / 4,4	

^(*) According to IEC/EN 60947-3 / Based in our own tests

^(*) Please consult us for more operations

For inverted mounting there are references for with inverted frontal plates. Supply under request.

S5000 size 3 + UM T2 / S5000 size 4 + UM T3

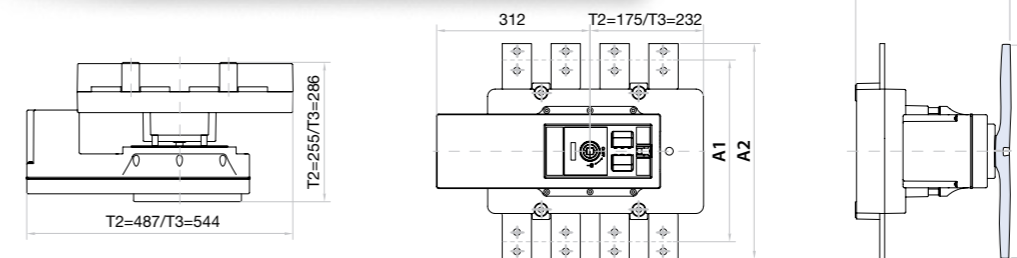

S5000 size 5 + UM T3

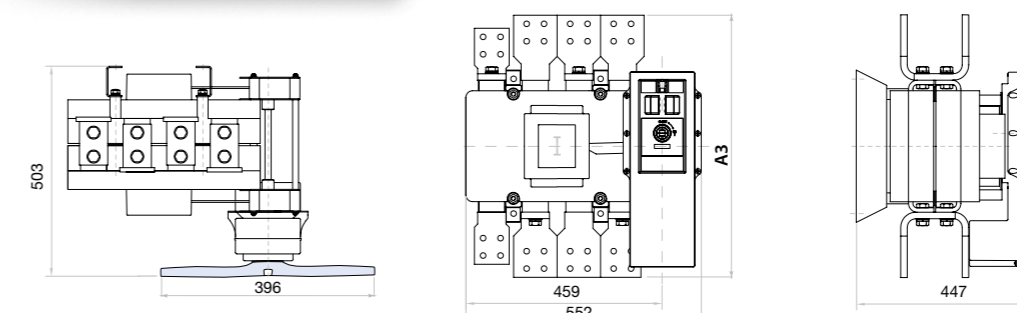

	A1
size 3-UM T2	290
size 3-UM T3	455 (2000A)
	A2
size 4-UM T3	381 (1000-1250A)
size 4-UM T3	441 (1600-2000A)
	A3
size 5-UM T3	543 (2000-2500A)
size 5-UM T3	603 (3150A)

UM-C Motorized unit kit for changeover switch S5000F & CCF



230 Vac/dc
SSF Size 0 | UM T0 UM-C0A230Z
CCF Size 1 | UM T0 UM-C1A230Z

	120 Vac/dc	230 Vac/dc	277 Vac/dc
CCF Size 2 UM T2	UM-C21120Z	UM-C21230Z	UM-C21277Z
Size 3 UM T3	UM-C31120Z	UM-C31230Z	UM-C31277Z
SSF Size 4 UM T3	UM-C35120Z	UM-C35230Z	UM-C35277Z

Technical information



According to IEC / EN 60947-3

Rated operational voltage	230Vac/dc	
Frequency	Hz	50/60
Operating voltage range (based in our own tests)	ΔV	0,85*V to 1,15*V
Operating voltage range according to IEC/EN 60947-6	ΔV	0,95*V to 1,10*V
Cable of voltage supply	mm ²	1,5 - 2,5
Cable section area Input Signals	mm ²	0,5 - 1,5
Cable section area Auto-Lock mode Outputs	mm ²	0,5 - 1,5
Inrush Current	A	1,1
Use current (I _{rms})	mA	45
Use current (I _{max})	mA	137
Protective Fuse (Ref. F1AL250V Littelfuse)	A	1
Operating angle		- 70° / 0° / +70° (I - 0 - II)
Number of UM T0 operations	Cycles	10000
Operation speed (0-I-II-0)	Cycles/hour	120
Operating temperature	RH90%	- 25°C + 55°C
Transportation and storage temperature	RH90%	- 40°C + 70°C
Weight	Kg	1,8

Pos.	Direction	Pos.	Operating time ^{*(1)}
0	→	I	0,75 sec
I	→	0	0,75 sec
0	→	II	0,75 sec
II	→	0	0,75 sec
I	→	II	1,5 sec
II	→	I	1,5 sec

^{*(1)} According to IEC/EN 60947-3 (based in our own tests)

Rated operational voltage	120Vac/dc	230Vac/dc	277Vac/dc
Frequency	Hz	50/60	
Operating voltage range (based in our own tests)	ΔV	0,85*V to 1,15*V	
Operating voltage range according to IEC/EN 60947-6	ΔV	0,95*V to 1,10*V	
Cable of voltage supply	mm ²	1,5 - 2,5	
Cable section area Input & MODBUS Signals	mm ²	0,5 - 1,5	
Cable section area Outputs	mm ²	0,5 - 1,5	
Inrush Current	A	17	
Nominal Current during operation UM T2	A	4,75	2,1
Nominal Current during operation UM T3	A	7,5	3,3
Use current (I _{rms})	A	0,041	
Use current (I _{max})	A	0,275	
Operation time CCF size 2 - UM T2	ms	180	174
Operation time SSF size 4 CCF C3 UM T3	ms	166	154
Number of UM T2 operations for CCF size 2 500 - 630A ^{*(1) *(2)}	Cycles	4000 / 10000	
Operation rate (0-I-II-0) for CCF size 2 500 - 630A ^{*(1)}	Cycles/hour	60 / 120	
Number of UM T2 operations for CCF size 2 800A ^{*(1) *(2)}	Cycles	2500 / 10000	
Operation rate (0-I-II-0) for CCF size 2 800A ^{*(1)}	Cycles/hour	20 / 120	
Number of UM T3 operations for SSF size 4 CCF size 3 ^{*(1) *(2)}	Cycles	2500 / 7000	
Operation rate (0-I-II-0) for SSF size 4 CCF size 3 ^{*(1)}	Cycles/hour	20 / 60	
Operating temperature	T/Un RH90%	-25°C + 55°C	
Transportation and storage temperature	RH90%	- 40°C + 70°C	
Weight T2/T3	Kg	3,96 / 4,4	

^{*(1)} According to IEC/EN 60947-3 / Based in our own tests

^{*(2)} Please consult us for more operations

For inverted mounting there are references for **MU** with inverted frontal plates. Supply under request.

Dimensions (mm)

UM T2-T3

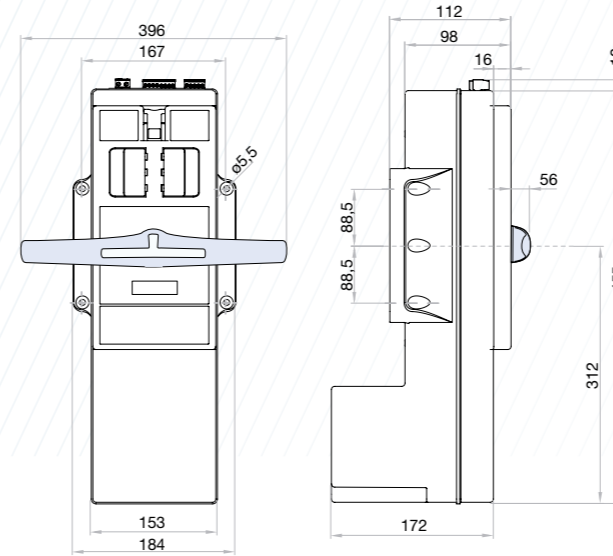

UM T0

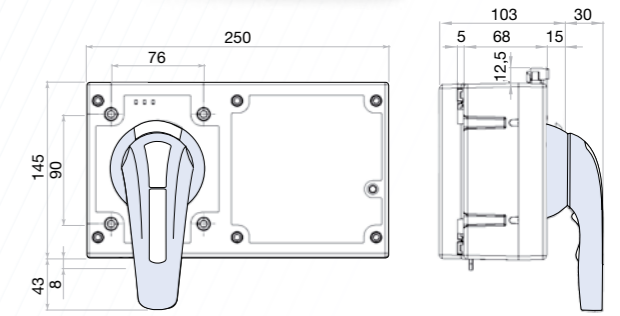

S5000F size 0 + UM T0

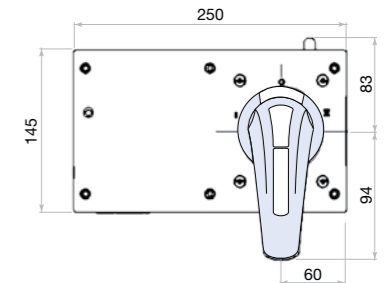
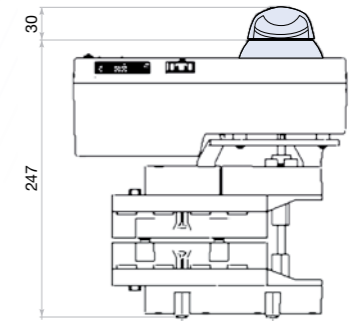

CCF size 2&3 + UM T2-T3

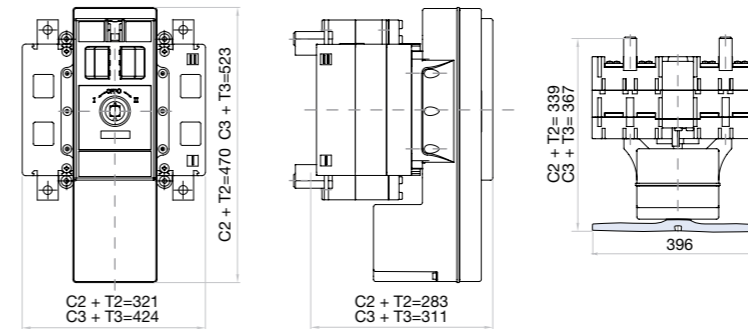

CCF size 1 + UM T0

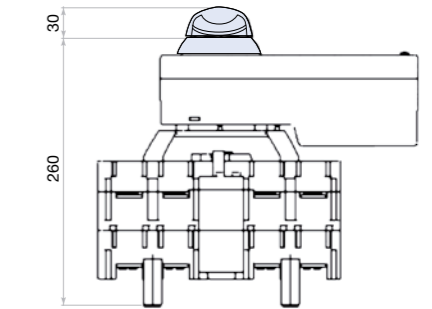

S5000F size 4 + UM T3

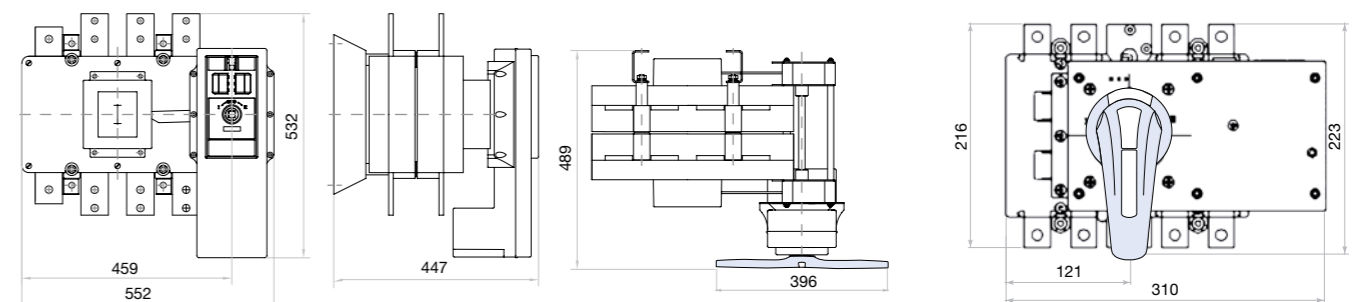

DC Switch - disconnectors

DC switch – disconnectors with high operating load capacity and a high level disconnection insulation; high reliability and safety in abnormal situations, available in different construction models, with a wide range of currents in different DC voltages and a variety of accessories.

series ZFV series S5 DC | S5M DC series S6 DC

According to:
IEC/EN 60947-1 y 3 IEC
UL508i
UL98B
RoHS

Testing and approvals:



The DC switch – disconnectors in its different series, are manufactured with high safety self-extinguishing materials, providing an excellent level of electrical insulation, low smoke emission and high resistance to electromechanical stress.

They comply with environmental requirements and undergo strict quality controls for a reliable product that meets the most demanding requirements.

They consist of a sandwich-type body containing self-cleaning blade type contacts,

with pre-arc zones to ensure long term, fault-free energy transmission and coated with silver alloy for long electromechanical life. The jump mechanism provides quick and independent switching due to the accumulation of elastic potential energy, which is transmitted at high speed to the contacts for arc extinction.

The switch - disconnectors S6 DC do not require external bridging links; thus reducing installation time and simplifying subsequent maintenance operations.

Functional and ergonomic handle

- > Good grip and excellent torque/resistance
- > Padlockable handle in **O OFF** position (up to three locks Ø 5-8 mm)
- > Door interlock in **ON I** position
- > Door interlock in **O OFF** position, with lock on
- > Release feature in **ON I** position (with the use of a tool for maintenance operations). The handle internal lock is automatically restored
- > Self-centering shaft for door handle



Relevant characteristics for photovoltaic installations

- > U_i (V) Rated insulation voltage 1000 Vdc.
- > U_{oc} (V) Open circuit voltage of the photovoltaic system.
- > U_{ef} (V) Photovoltaic installation functioning voltage on load.
- > I_{ef} (A) Installation working current under load.
- > I_{sc} (A) Short-circuit current of the photovoltaic installation.
- > In certain places of Pv Systems, inductive component must be considered (cables, inverter, etc.).
- > The sizing of the switch must be done considering open circuit voltage as maximum operation voltage.

- > It is necessary to comply with:
 $U_i \geq U_{oc}$
We recommend to set U_i between 10 and 15% over U_{oc} .
 $U_e \geq U_{ef}$
 $I_e \geq I_{ef}$
 $I_e \geq I_{sc}$

Range coding:

The DC S5|S5M|S6|S6N series, are identified by a code that describes their most important characteristics as described below.

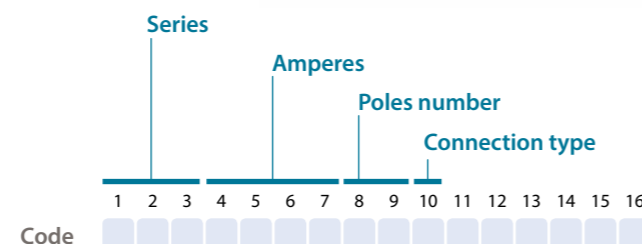

series ZFV



IP66

1 2 3 4 5 6
Z F V

Small design.
Base mounting by screws or DIN rail.
Non polarized.
Up to 1500Vdc.

series S5 DC



1 2 3 4 5 6
S 5 -

Wide range of currents.
Base mounting by screws.
Non polarized.
Up to 1000Vdc.

series S5M DC



1 2 3 4 5 6
S 5 M

Back to back arrangement.
Base mounting by screws.
Non polarized.
Multi-string 1000Vdc.
3P+3P o 4P+4P 1500Vdc.

series ZFV



IP66

1 2 3 4 5 6
Z F V

ZFV plastic enclosed switch.
Non polarized.
Up to 1500Vdc.

series S6 DC



1 2 3 4 5 6
S 6 -

Wide range of currents.
Different configurations to choose.
Base mounting by screws.
Non polarized.
Up to 1000Vdc.

series S6N DC



1 2 3 4 5 6
S 6 N

Back to back arrangement.
Different configurations to choose.
Base mounting by screws.
Non polarized.
Up to 1500Vdc.

ZFV Switch - disconnecter for DC current 2P

Size 00-0
A 16|25|32|40|55
600 - 1000 - 1500 Vdc

IP66

Accessories

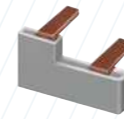

>> Insulated bridging links included
CODE ZFV-B1 16-32 A
ZFV-B2 40-55 A

Dimensions (mm)

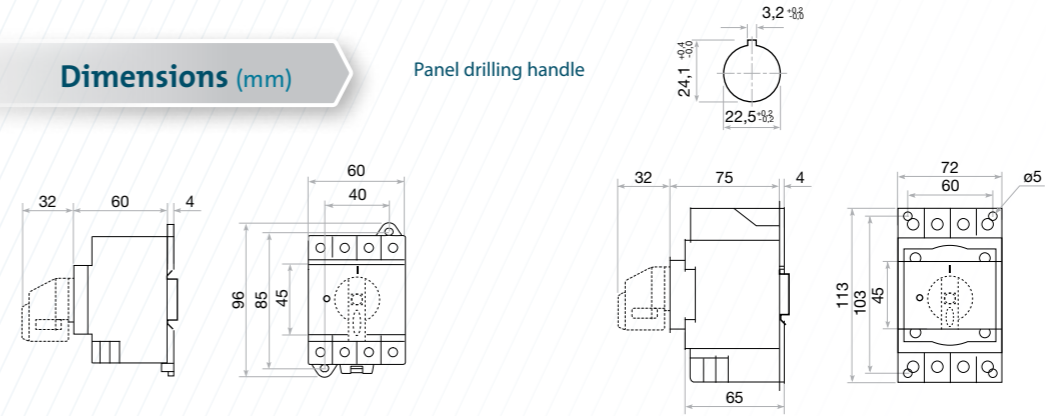

ZFV16-32

ZFV40-55

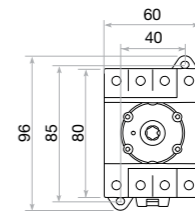
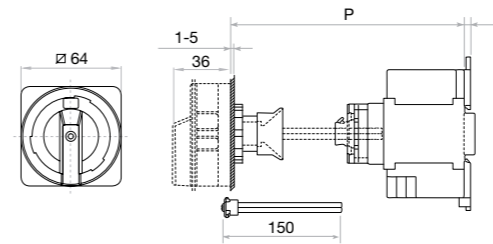

P
max = 150
min = 89
Other lengths (shafts) are available under request

ZFV16-32

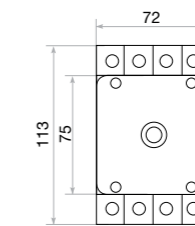
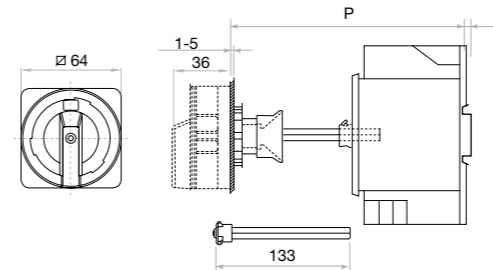

P
max = 194
min = 103
Other lengths (shafts) are available under request

ZFV40-55

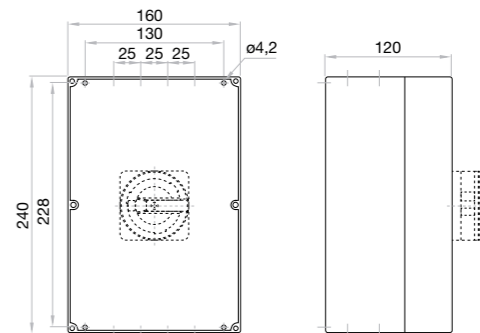
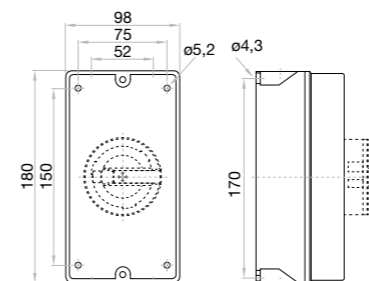
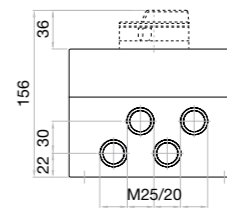
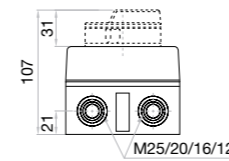

ZFV32

ZFV55

CODE 2P	16A	25A	32A	40A	55A
ZFV16SMAH1A40	ZFV16VZVH4A40	-	-	-	-
ZFV25SMAH1A40	ZFV25VZVH4A40	-	-	-	-
ZFV32SMAH1A40	ZFV32VZVH4A40	-	-	-	-
ZFV40SMAH1A40	ZFV40VZVH4A40	-	-	-	-
ZFV55SMAH1A40	ZFV55VZVH4A40	-	-	-	-

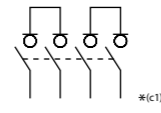

Technical information



According to IEC/EN 60947-3
UL508i

IEC/EN 60947-3		ZFV16	ZFV25	ZFV32	ZFV40	ZFV55
Rated operational current	le DC21B 2 Poles in series	IEC 1000Vdc A 9	11	13	20	25
	le DC21B 4 Poles in series	IEC 1500Vdc A 3	4	5	6	8
Rated conditional short-circuit current		1000Vdc A 16	25	32	40	55
Max. fuse size		1500Vdc A 16	20	23	30	40
Maximum cable cross sections (included jumper)		kAeff 5	5	5	10	10
Solid or stranded		gL (gG) A 40	63	80	125	160
Flexible		mm ² 4-16	4-16	4-16	2,5-25	2,5-25
Flexible (+ multicore cable end)		mm ² 4-10	4-10	4-10	4-16	4-16
Size of terminal screw		mm ² 4-10	4-10	4-10	2,5-16	2,5-16
Tightening torque		M4 Pz2	M4 Pz2	M4 Pz2	M5Pz2	M5Pz2
		Nm 1,7-1,8	1,7-1,8	1,7-1,8	2,5-2,8	2,5-2,8

UL508i LISTED E362647		ZFV16	ZFV25	ZFV32	ZFV40	ZFV55
Ampere-Rating "General use"	2 Poles in series	UL 600Vdc A 16	20	25	40	55
	4 Poles in series	UL 1000Vdc A -	-	-	16	20
Fuse size (RK5) 5 kA/600V	Industrial Control Switch	UL 600Vdc A 16	25	32	40	55
Fuse size (RK5) 5 kA/1000V	Industrial Control Switch	UL 1000Vdc A -	-	-	40	55
Maximum cable cross sections (included jumper)		A 40	60	80	-	-
Solid or stranded		-	-	-	90	125
Flexible		AWG 12-10	12-10	12-10	16-10	16-10
Flexible (+ multicore cable end)		AWG 12-6	12-6	12-6	14-4	14-4
Size of terminal screw		AWG 12-6	12-6	12-6	-	-
Tightening torque		M4 Pz2	M4 Pz2	M4 Pz2	M5Pz2	M5Pz2
		Nm 1,7-1,8	1,7-1,8	1,7-1,8	2,5-2,8	2,5-2,8

* (c1) Other configurations are available under request

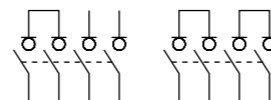



S5000 DC Switch - disconnecter for DC current 4P

Size 0

A 40

900Vdc

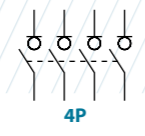
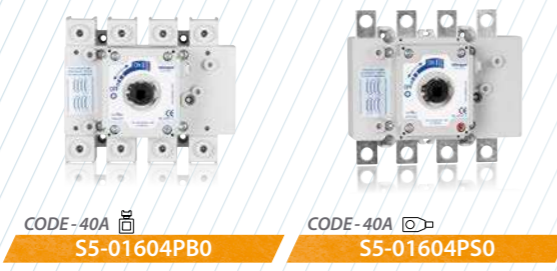

Technical information



According to IEC/EN 60947-1
IEC/EN 60947-3

		40	
Rated thermal current in ambient at	lth 40° C	A	40
	50° C	A	40
	60° C	A	40
Rated insulation voltage DC20	Ui	V	1000
Rated dielectric strength	50 Hz., 1 min.	V	4000
Rated impulse withstand voltage	Uimp	kV	8
Rated operational current ^{*(1)} DC21B	Ue		
	le 900 Vdc	A	40

Short - circuit behaviour

Short - circuit making capacity ^{*(2)}	Icm	kA (peak)	13
Maximum power dissipation		A ² s (x 10 ³)	198
Minimum number of mechanical operations ^{*(3)}		Cycles	30000
Minimum number of electrical operations	DC21B 900V	Cycles	300
Maximum weight (without jumpers)		Kg	1

^{*(1)} Other voltages and / or utilization categories. Please consult
^{*(2)} Without limiting protective device (short-circuit maintained 50... 100 ms.)
^{*(3)} Please consult us for more operations

Connection diagram

Connection diagram

Bridging links

Terminal protection

Accessories

- >> Direct handle**
CODE DS-SI01
- >> Panel handle** included shaft ^{*(e1)}
IP65
CODE DS-SA01
- >> Panel handle** without shaft
IP65
CODE DS-SA03
- >> Auxiliary contacts**
1NO+1NC CODE D5LAU01
2NO+2NC CODE D5LAU02

Ie = 16 A (resistive loads)
4 A (inductive loads) at 250 Vac.
- >> Terminal protection**
CODE DS-CU01
(1 unit for input or output)
- >> Bridging links** (2 units)
A B CODE DS-PI05
C CODE DS-PI01
CONSULT
- >> DIN rail mounting**
CODE DS-DN01
(1 kit)

>> Shafts

Standard shaft included ^{*(e1)}

L (mm)	P (mm)	CODE
177	87...197,5	

Shaft extensions

Type 1

L (mm)	P (mm)	CODE
250	87...278	DS-EP04

Type 2

L (mm)	P (mm)	CODE
387	87...415	DS-EP05

Dimensions (mm)

Panel drilling for panel handle

For panel handle

S max (Cu)	M
mm ²	Nxm
95	4

S max (Cu)	H max (Cu)	L max (Cu)	M
mm ²	mm	mm	Nxm
95	5	25	M8 13



S5000 DC Switch - disconnecter for DC current 4P

Size 1
A 100|160|250|400
 1000Vdc

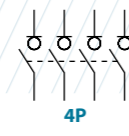

Technical information

According to IEC/EN 60947-1
IEC/EN 60947-3



			100	160	250	400
Rated thermal current in ambient at	40° C	A	125	200	315	400
	50° C	A	125	200	315	400
	60° C	A	125	200	280	320
Rated insulation voltage DC20	Ui	V	1500	1500	1500	1500
Rated dielectric strength	50 Hz., 1 min.	V	5000	5000	5000	5000
Rated impulse withstand voltage	Uimp	kV	8	8	8	8
Rated operational current ⁽¹⁾	Ie Ue	A	100	160	250	400
DC21B		A	100	160	250	400

			100	160	250	400
Short - circuit behaviour						
Short - circuit making capacity ⁽²⁾	Icm	kA (peak)	20	20	20	20
Maximum power dissipation	A²s (x 10³)		1000	1000	1000	1000
Minimum number of mechanical operations ⁽³⁾	Cycles		20000	20000	20000	20000
Minimum number of electrical operations	DC21B 1000V Cycles		200	200	200	200
Maximum weight (without jumpers)	Kg		1,9	1,9	1,9	1,9

⁽¹⁾ Other voltages and / or utilization categories. Please consult
⁽²⁾ Without limiting protective device (short-circuit maintained 50... 100 ms.)
⁽³⁾ Please consult us for more operations

Connection diagram

Connection diagram

Bridging links

Terminal shrouds

Accessories

- Direct handle**
CODE DS-SI11
- Panel handle** included shaft ^(e1)
IP65|UL50E/NEMA 250
Types: 1, 3R, 4, 4X y 12
CODE DS-SA11
- Panel handle** without shaft
IP65|UL50E/NEMA 250
Types: 1, 3R, 4, 4X y 12
CODE DS-SA14
- Shafts**
Standard shaft included ^(e1)

L (mm)	P (mm)	CODE
227	103... 256	

Shaft extensions

Type 1		
L (mm)	P (mm)	CODE
375	103... 415	DS-EP14
Type 2		
L (mm)	P (mm)	CODE
536	103... 576	DS-EP15
- Auxiliary contacts**
1NO+1NC CODE D5LAU01
2NO+2NC CODE D5LAU02
 Ie = 16 A (resistive loads)
 4 A (inductive loads) at 250 Vac.
- Terminal protection**
CODE DS-CU12
(1 unit for input or output)
- Terminal shrouds** (2 units)

	A	B	C
TOP	DS-CU18	DS-CU10	DS-CU10
BOTTOM	DS-CU19	DS-CU11	DS-CU18
- Bridging links** (2 units)

	A	B	C
CODE	DS-PI11	DS-PI14	CONSULT

Dimensions (mm)

Panel drilling for panel handle

	H	I	J	øT
100 A	130	150	20	M8
160 A	143	167	25	M10

	S max (Cu) mm²	H max (Cu) mm	L max (Cu) mm	M
100 A	185	7	25	M8
160 A				M10
250 A				M18

	S max (Cu) mm²	Z max	H max (Cu) mm	L max (Cu) mm	M
400 A	240	44	7	40	M10 24



S5000 DC Switch - disconnecter for DC current 4P - 2P

Size 2
A 500|630
 1000Vdc

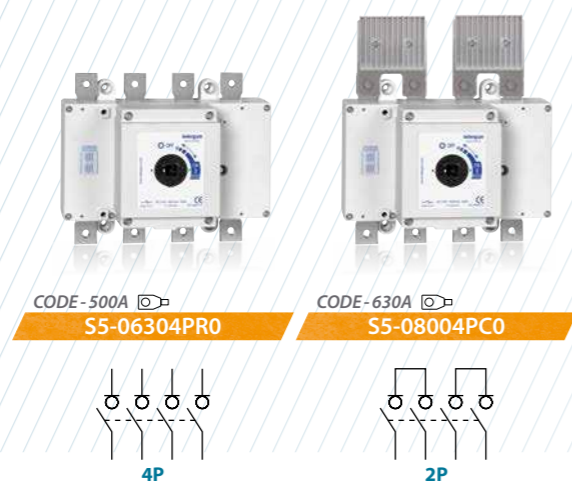

Technical information

According to IEC/EN 60947-1
 IEC/EN 60947-3



		500		630	
Rated thermal current in ambient at	lth	40° C	A	500	630
		50° C	A	500	630
		60° C	A	400	500
Rated insulation voltage DC20	Ui	V	1500	1500	
Rated dielectric strength	50 Hz., 1 min.	V	8000	8000	
Rated impulse withstand voltage	Uimp	kV	12	12	
Rated operational current ⁽¹⁾	le	Ue			
	DC21B	1000 Vdc	A	500	630

tests:

		500		630	
Short - circuit behaviour					
Short - circuit making capacity ⁽²⁾	lcm	kA (peak)	26	26	
Maximum power dissipation	A ² s (x 10 ³)		1600	1600	
Minimum number of mechanical operations ⁽³⁾		Cycles	10000	10000	
Minimum number of electrical operations	DC21B 1000V	Cycles	200	200	
Maximum weight (without jumpers)		Kg	4,5	4,5	

⁽¹⁾ Other voltages and / or utilization categories. Please consult
⁽²⁾ Without limiting protective device (short-circuit maintained 50... 100 ms)
⁽³⁾ Please consult us for more operations

Connection diagram

Connection diagram

Bridging links

Terminal shrouds

A S5-06304PRO

B S5-06304PRO
S5-08004PCO

C

Accessories

Direct handle
 CODE DS-LI21

Panel handle included shaft ^(e1)
 IP65|UL50E/NEMA 250
 Types: 1, 3R, 4, 4X y 12
 CODE DS-LA21

Panel handle without shaft
 IP65|UL50E/NEMA 250
 Types: 1, 3R, 4, 4X y 12
 CODE DS-LA24

Shafts
Standard shaft included ^(e1)
 L (mm) | P (mm) |
 195 | 134... 240 |

Shaft extensions
 Type 1
 L (mm) | P (mm) | CODE
 345 | 134... 400 | DS-EP23
 Type 2
 L (mm) | P (mm) | CODE
 535 | 134... 560 | DS-EP24

Auxiliary contacts
 1NO+1NC CODE D5LAU01
 2NO+2NC CODE D5LAU02
 Ie = 16 A (resistive loads)
 4 A (inductive loads) at 250 Vac.

Terminal protection
 CODE DS-CU22
 (1 unit for input or output)

Terminal shrouds (2 units for 4P)

	A	B	C
TOP	DS-CU28	DS-CU20	DS-CU20
BOTTOM	DS-CU29	DS-CU21	DS-CU28

Bridging links (2 units)
 For S5-06304PRO B CODE DS-PI21 (2 units)
 A C CONSULT

^(P2) For S5-08004PCO B CODE DS-PI2D (2 units)
 A C CONSULT

^(P2) To meet the operation and electrical features, the product installed must be incorporate these bridging links. Please consult.

Dimensions (mm)

Panel drilling for panel handle

500 A

630 A

S max (Cu)	H max (Cu)	L max (Cu)	T	M
mm ²	mm	mm		Nxm
2x240	2x5	40 50	M10	24

S5000 DC Switch - disconnecter for DC current 4P - 2P

Size 3

A 850|1250

1000Vdc



Technical information



tests:
AIT AUSTRIAN INSTITUTE OF TECHNOLOGY
TOMORROW TODAY

According to IEC/EN 60947-1
IEC/EN 60947-3

		850		1250	
Rated thermal current in ambient at	Ith	40° C	A	850	1250
		50° C	A	850	1250
		60° C	A	700	1000
Rated insulation voltage DC20	Ui	V	1500	1500	
Rated dielectric strength	50 Hz, 1 min.	V	8000	8000	
Rated impulse withstand voltage	Uimp	kV	12	12	
Rated operational current ^{*(1)}	le	Ue			
	DC21B	1000 Vdc	A	850	1250

		850		1250	
Short - circuit behaviour					
Short - circuit making capacity ^{*(2)}	Icm	kA (peak)	60	60	
Maximum power dissipation		A ² s (x 10 ³)	4900	4900	
Minimum number of mechanical operations ^{*(3)}		Cycles	10000	10000	
Minimum number of electrical operations	DC21B	Cycles	100	100	
	1000V				
Maximum weight (without jumpers)		Kg	7,6	7,6	

^{*(1)} Other voltages and / or utilization categories. Please consult
^{*(2)} Without limiting protective device (short-circuit maintained 50... 100 ms.)
^{*(3)} Please consult us for more operations

Connection diagram

Connection diagram

Bridging links

Terminal shrouds

A S5-12504PC0

B S5-12504PC0
S5-12502ECO

C

Accessories

Direct handle
CODE DS-LI31

Panel handle included shaft ^{*(e1)}
IP65|UL50E/NEMA 250
Types: 1, 3R, 4, 4X y 12
CODE DS-LA31

Panel handle without shaft
IP65|UL50E/NEMA 250
Types: 1, 3R, 4, 4X y 12
CODE DS-LA33

Auxiliary contacts
1NO+1NC CODE D5LAU01
2NO+2NC CODE D5LAU02
le = 16 A (resistive loads)
4 A (inductive loads) at 250 Vac.

Terminal shrouds (2 units for 4P)

	A	B	C
TOP	DS-CU38	DS-CU30	DS-CU30
BOTTOM	DS-CU39	DS-CU31	DS-CU38

Shafts

Standard shaft included ^{*(e1)}

L (mm)	P (mm)	CODE
186	145... 242	

Shaft extensions

Type 1

L (mm)	P (mm)	CODE
336	145... 402	DS-EP32

Type 2

L (mm)	P (mm)	CODE
535	145... 600	DS-EP24

Bridging links

(2 units)

For S5-12504PC0 **A B** CODE DS-PI31 (2 units)
C CONSULT

^{*(P2)} For S5-12502ECO **B** CODE DS-PI3D (2 units)
A C CONSULT

^{*(P2)} To meet the operation and electrical features, the product installed must be incorporate these bridging links. Please consult.

Dimensions (mm)

Panel drilling for panel handle

850 A

1250 A

S max (Cu)	H max (Cu)	L max (Cu)	T	M
mm ²	mm	mm		Nxm
2x300	2x10	50	M14	45

S5000 DC Switch - disconnecter for DC current 4P - 2P

Size 4
A 1250|1800|2000
 1000Vdc

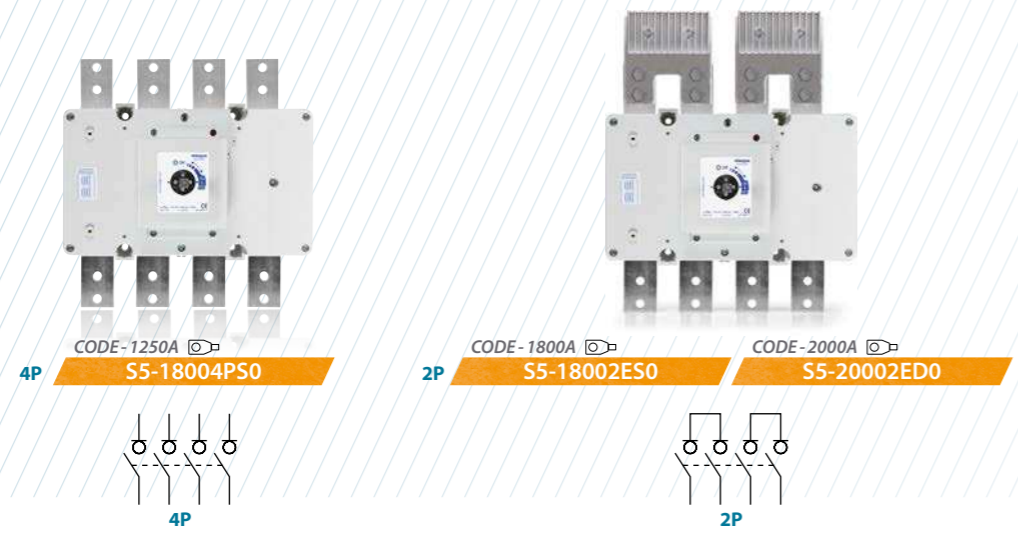

CODE-1250A S5-18004PS0

CODE-1800A S5-18002ES0

CODE-2000A S5-20002ED0

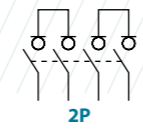
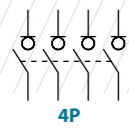

Technical information

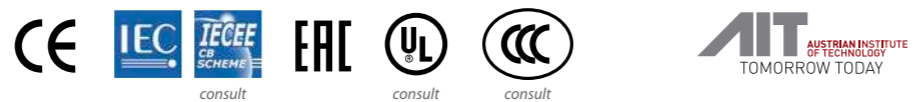

According to IEC/EN 60947-1
 IEC/EN 60947-3

			1250	1800	2000
Rated thermal current in ambient at	lth	40° C	A 1250	1800	2000
		50° C	A 1250	1620	1800
		60° C	A 1250	1400	1600
Rated insulation voltage DC20	Ui	V	1500	1500	1500
Rated dielectric strength	50 Hz, 1 min.	V	10000	10000	10000
Rated impulse withstand voltage	Uimp	kV	12	12	12
Rated operational current ⁽¹⁾	Ie	Ue			
		DC21B	1000Vdc	A 1250	1800

			1250	1800	2000
Short - circuit behaviour					
Short - circuit making capacity ⁽²⁾	Icm	kA (peak)	60	60	60
Minimum number of mechanical operations ⁽³⁾		Cycles	10000	10000	10000
Minimum number of electrical operations	DC21B 1000V	Cycles	100	100	100
Maximum weight (without jumpers)		Kg	20,8	20,8	20,8

⁽¹⁾ Other voltages and/or utilization categories. Please consult
⁽²⁾ Without limiting protective device (short-circuit maintained 50... 100 ms.)
⁽³⁾ Please consult us for more operations

Connection diagram

Connection diagram

A S5-18004PS0

B S5-18004PS0
S5-18002ES0
S5-20002ED0

C

Bridging links

Terminal shrouds

Accessories

>> Direct handle
 CODE DS-LI41

>> Panel handle included shaft ^(e1)
 IP65|UL50E/NEMA 250
 Types: 1, 3R, 4, 4X y 12
 CODE DS-LA41

>> Panel handle without shaft
 IP65|UL50E/NEMA 250
 Types: 1, 3R, 4, 4X y 12
 CODE DS-LA43

>> Shafts

Standard shaft included ^(e1)

L (mm)	P (mm)	CODE
239	235... 400	

Shaft extensions

Type 1		
L (mm)	P (mm)	CODE
485	235... 686	DS-EP44
Type 2		
L (mm)	P (mm)	CODE
635	235... 836	DS-EP45

>> Auxiliary contacts

1NO+1NC CODE D5LAU01
 2NO+2NC CODE D5LAU02

Ie = 16 A (resistive loads)
 4 A (inductive loads) at 250 Vac.

>> Terminal shrouds (2 units for 4P)

	A	B	C
TOP	DS-CU48	DS-CU40	DS-CU40
BOTTOM	DS-CU49	DS-CU41	DS-CU48

>> Bridging links (2 units)

For S5-18004PS0 **A B** CODE DS-PI41 (2 units)
C CONSULT

^(P2) For S5-18002ES0 S5-20002ED0 **B** CODE DS-PI4D (2 units)
C CONSULT

^(P2) To meet the operation and electrical features, the product installed must incorporate these bridging links. Please consult.

Dimensions (mm)

Panel drilling for panel handle

1250 A

1800 A
2000 A

H max (Cu)	L max (Cu)	M
2x7	80	M14 55



S5000 DC Switch - disconnecter for DC current 2P

Size 5
A 2000|2500|3150
 1000Vdc



CODE-2000A S5-20002ES0 CODE-2500A S5-25002ES0 CODE-3150A S5-31502ES0

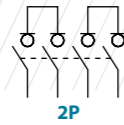

Technical information



According to IEC/EN 60947-1
IEC/EN 60947-3

		2000 2500 3150			
Rated thermal current in ambient at	40° C	A	2000	2500	3150
	50° C	A	2000	2500	2850
	60° C	A	2000	2205	2500
Rated insulation voltage DC20	Ui	V	1500	1500	1500
Rated dielectric strength	50 Hz., 1 min.	V	10000	10000	10000
Rated impulse withstand voltage	Uimp	kV	8	8	8
Rated operational current DC21B ^{*(1)}	le	Ue	2000	2500	3150
		1000 Vdc	A		

		2000 2500 3150			
Short - circuit behaviour					
Short - circuit making capacity ^{*(2)}	Icm	kA (peak)	80	80	80
Minimum number of mechanical operations ^{*(3)}		Cycles	2500	2500	2500
Minimum number of electrical operations	DC21B 1000V	Cycles	100	100	100
Maximum weight (without jumpers)		Kg	58	58	58

^{*(1)} Other voltages and / or utilization categories. Please consult
^{*(2)} Without limiting protective device (short-circuit maintained 50... 100 ms.)
^{*(3)} Please consult us for more operations

Accessories



» Direct handle
CODE DS-LI41



» Panel handle included shaft ^{*(e1)}
IP65|UL50E/NEMA 250
Types: 1, 3R, 4, 4X y 12
CODE DS-LA41



» Panel handle without shaft
IP65|UL50E/NEMA 250
Types: 1, 3R, 4, 4X y 12
CODE DS-LA43

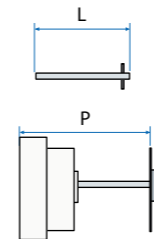

» Shafts
Standard shaft included ^{*(e1)}
L (mm) | P (mm)
239 | 420... 580



» Auxiliary contacts
1NO+1NC CODE DS-AU11
2NO+2NC CODE DS-AU12
le = 16 A (resistive loads)
4 A (inductive loads) at 250 Vac.



» Bridging links ^{*(P2)}
2000A CODE DS-PI51 (2 units) + D5LPC45 (4 units)
2500A CODE DS-PI51 (2 units) + D5LPC45 (4 units)
3150A CODE x2 DS-PI4D (2 units) + x2 D5LPC45 (4 units)

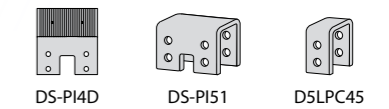

^{*(P2)} To meet the operation and electrical features, the product installed must be incorporate these bridging links. Please consult.

Dimensions (mm)

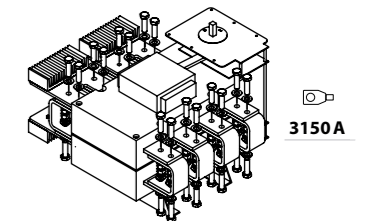
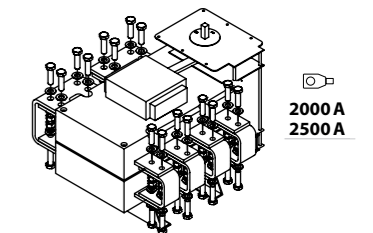
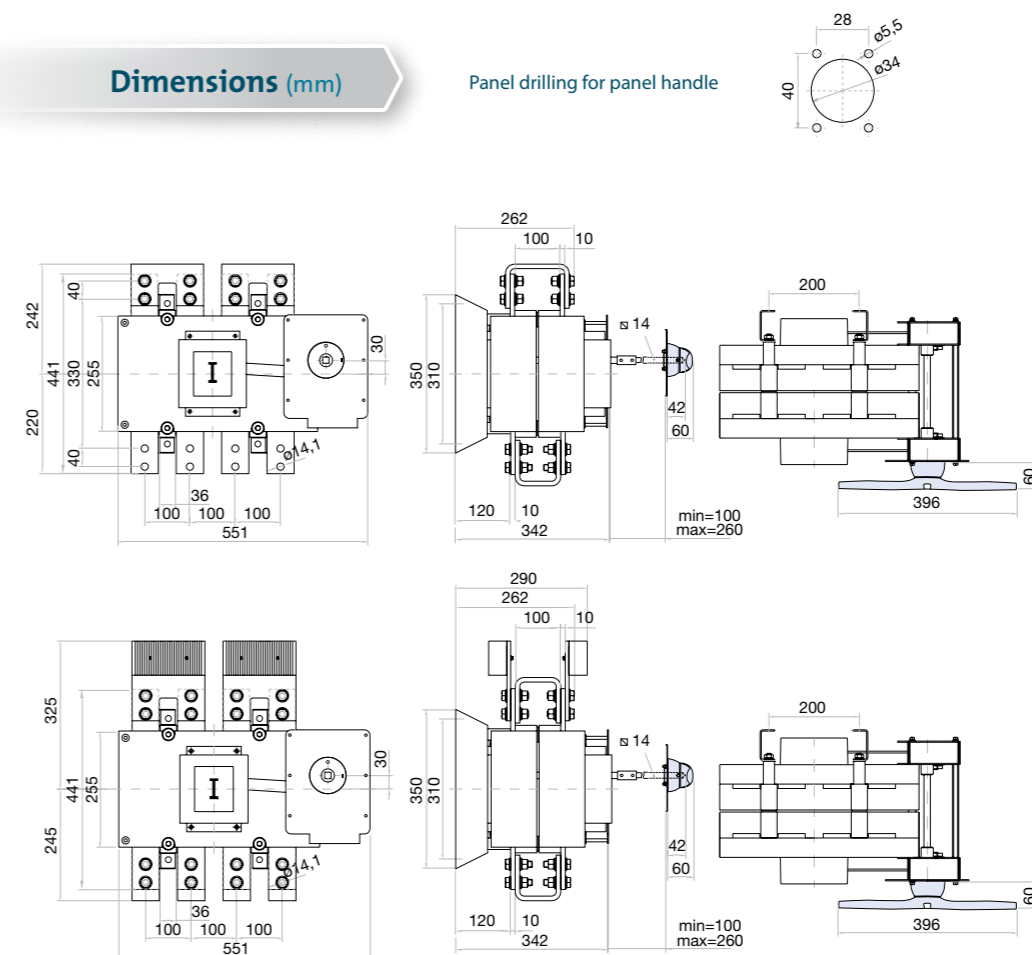

H max (Cu)	L max (Cu)	M
mm	mm	Nxm
3x12	80	M14 45

S5000M DC Switch - disconnecter for DC current 8P (multi-string)



Size 1

A 250

1000Vdc

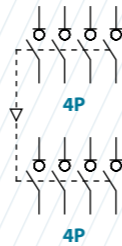

Technical information



According to IEC/EN 60947-3
GB14048.3



Rated thermal current in ambient at	I _{th}	40° C	A	250
		50° C	A	250
		60° C	A	250
Rated insulation voltage DC20	U _i	V	1500	
Rated dielectric strength	50 Hz, 1 min.	V	5000	
Rated impulse withstand voltage	U _{imp}	kV	8	
Rated operational current ^{*(1)} DC21B	I _e	U _e		
		400 Vdc	A	250
		600 Vdc	A	250
		800 Vdc	A	250
		1000 Vdc	A	250

Short - circuit behaviour			
Short - circuit making capacity ^{*(2)}	I _{cm}	kA (peak)	20
Maximum power dissipation	A ² s (x 10 ³)	1000	
Minimum number of mechanical operations ^{*(3)}	Cycles	20000	
Minimum number of electrical operations	DC21B 1000Vdc	Cycles	200
Maximum weight	Kg	5,8	

^{*(1)} Other voltages and / or utilization categories. Please consult
^{*(2)} Without limiting protective device (short-circuit maintained 50... 100 ms.)
^{*(3)} Please consult us for more operations

Connection diagram

Connection diagram

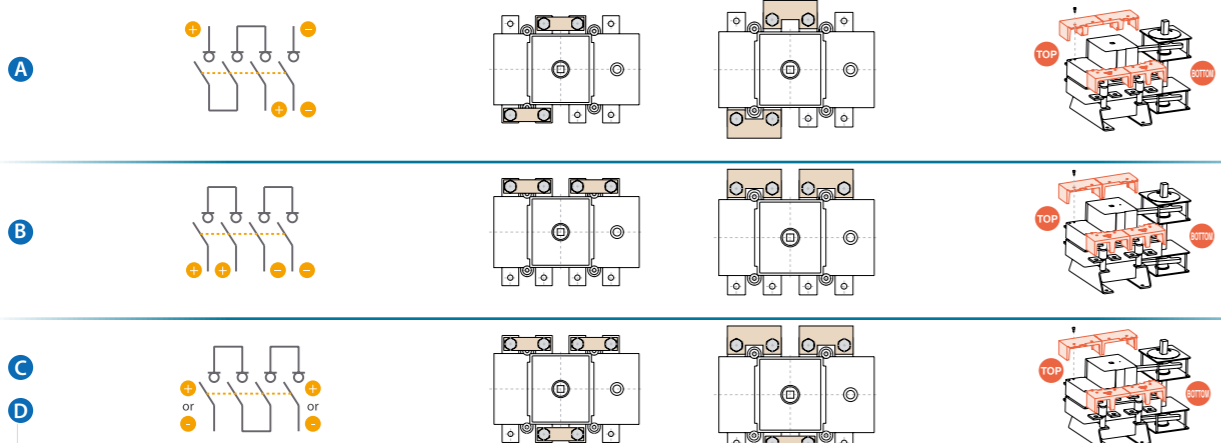

Accessories

- Direct handle**
CODE DS-LI12
- Panel handle** included shaft ^{*(e1)}
IP65|UL50E/NEMA 250
Types: 1, 3R, 4, 4X y 12
CODE DS-LA12
- Panel handle** without shaft
IP65|UL50E/NEMA 250
Types: 1, 3R, 4, 4X y 12
CODE DS-LA15
- Shafts**
Standard shaft included ^{*(e1)}
L (mm) | P (mm)
277 | 288... 422
- Auxiliary contacts**
1NO+1NC CODE DS-AU11
2NO+2NC CODE DS-AU12
I_e = 16 A (resistive loads)
4 A (inductive loads) at 250 Vac.
- Terminal shrouds** (2 units)
TOP: DS-CU18 (A), DS-CU10 (B), DS-CU10 (C, D)
BOTTOM: DS-CU19 (A), DS-CU11 (B), DS-CU18 (C, D)
The shrouds can only be fitted in the front switch.
- Bridging links** (2 or 3 units)
A B CODE DS-PI120U | C D CODE DS-PI130U
A B CODE DS-PI170U | C D CODE DS-PI160U

Dimensions (mm)

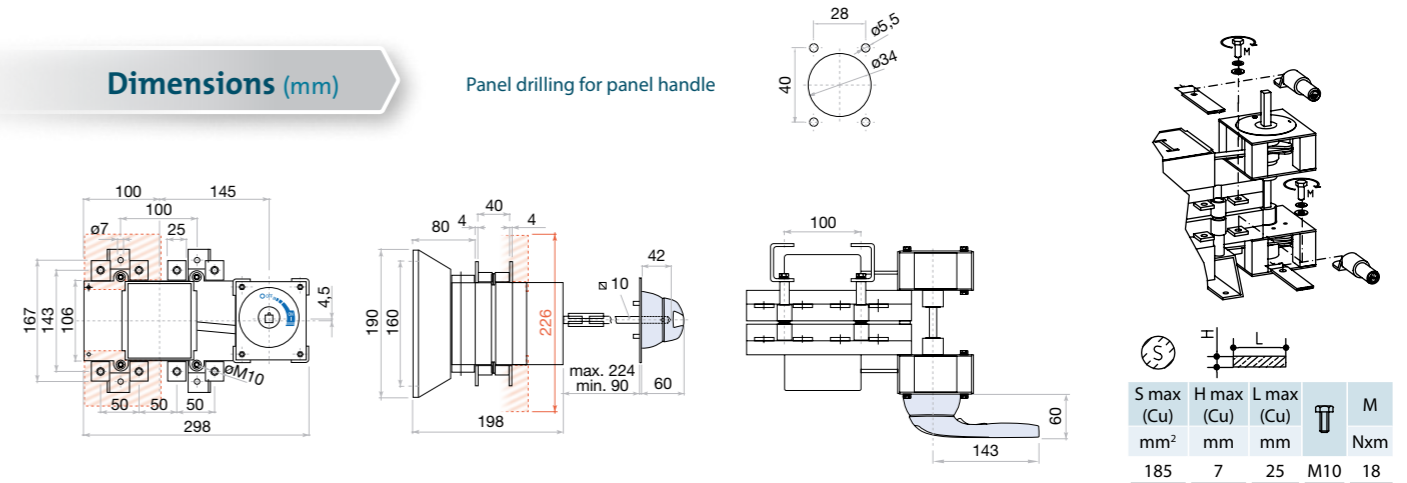

S5000M DC Switch - disconnecter for DC current 8P (multi-string)



Size 2

A 400

1000Vdc

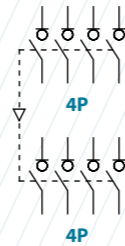

Accessories



» **Direct handle**
CODE DS-LI22



» **Panel handle** included shaft ^{*(e1)}
IP65|UL50E/NEMA 250
Types: 1, 3R, 4, 4X y 12
CODE DS-LA22

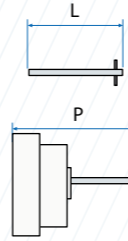

» **Shafts**
Standard shaft included ^{*(e1)}
L (mm) | P (mm)
239 | 325... 490



» **Auxiliary contacts**
1NO+1NC CODE DS-AU11
2NO+2NC CODE DS-AU12
I_e = 16 A (resistive loads)
4 A (inductive loads) at 250 Vac.



» **Terminal shrouds** (2 units)

	A	B	C D
TOP	DS-CU28	DS-CU20	DS-CU20
BOTTOM	DS-CU29	DS-CU21	DS-CU28

The shrouds can only be fitted in the front switch.



» **Bridging links** (2 or 3 units)

	A B	CODE DS-PI220U	C D	CODE DS-PI230U
	A B	CODE DS-PI270U	C D	CODE DS-PI260U

Technical information



According to IEC/EN 60947-3
GB14048.3

Rated thermal current in ambient at	I _{th}	40° C	A	400
		50° C	A	400
		60° C	A	400
Rated insulation voltage DC20	U _i	V	1500	
Rated dielectric strength	50 Hz, 1 min.	V	8000	
Rated impulse withstand voltage	U _{imp}	kV	12	
Rated operational current ^{*(1)} DC21B	I _e	U _e		
		400 Vdc	A	400
		600 Vdc	A	400
		800 Vdc	A	400
		1000 Vdc	A	400

^{*(1)} Other voltages and / or utilization categories. Please consult
^{*(2)} Without limiting protective device (short-circuit maintained 50... 100 ms.)
^{*(3)} Please consult us for more operations

Connection diagram

Connection diagram

	Connection diagram	Bridging links		Terminal shrouds (On front switch only)
		Front switch	Rear switch	
A				
B				
C D				

tests:



Short - circuit behaviour			
Short - circuit making capacity ^{*(2)}	I _{cm}	kA (peak)	26
Maximum power dissipation		A ² s (x 10 ³)	1600
Minimum number of mechanical operations ^{*(3)}		Cycles	10000
Minimum number of electrical operations	DC21B 1000Vdc	Cycles	200
Maximum weight		Kg	13

Dimensions (mm)

Panel drilling for panel handle

S max (Cu) mm ²	H max (Cu) mm	L max (Cu) mm	T	M
2x240	2x5	40	M10	24

S5000M DC Switch - disconnecter for DC current 8P (multi-string)

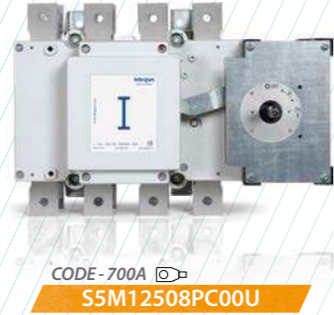

Size 3

A 700

1000Vdc

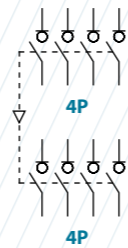

Technical information



According to IEC/EN 60947-3
GB14048.3



Rated thermal current in ambient at	I _{th}	40° C	A	700
		50° C	A	700
		60° C	A	700
Rated insulation voltage DC20	U _i	V	1500	
Rated dielectric strength	50 Hz, 1 min.	V	8000	
Rated impulse withstand voltage	U _{imp}	kV	12	
Rated operational current ^{*(1)} DC21B	I _e	U _e		
		400 Vdc	A	700
		600 Vdc	A	700
		800 Vdc	A	700
		1000 Vdc	A	700

Short - circuit behaviour

Short - circuit making capacity ^{*(2)}	I _{cm}	kA (peak)	60
Maximum power dissipation	A ² s (x 10 ³)	4900	
Minimum number of mechanical operations ^{*(3)}	Cycles	10000	
Minimum number of electrical operations	DC21B 1000Vdc	Cycles	100
Maximum weight	Kg	20	

^{*(1)} Other voltages and / or utilization categories. Please consult
^{*(2)} Without limiting protective device (short-circuit maintained 50... 100 ms.)
^{*(3)} Please consult us for more operations

Connection diagram

Connection diagram

A		Bridging links		
		Front switch	Rear switch	
B		Bridging links		
		Front switch	Rear switch	
C D		Bridging links		
		Front switch	Rear switch	

Accessories



Direct handle
CODE DS-LI41



Panel handle included shaft ^{*(e1)}
IP65|UL50E/NEMA 250
Types: 1, 3R, 4, 4X y 12
CODE DS-LA41



Panel handle without shaft
IP65|UL50E/NEMA 250
Types: 1, 3R, 4, 4X y 12
CODE DS-LA43

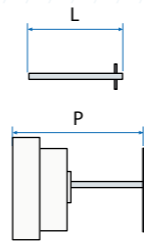

Shafts
Standard shaft included ^{*(e1)}
L (mm) | P (mm)
239 | 408... 573



Auxiliary contacts
1NO+1NC CODE DS-AU11
2NO+2NC CODE DS-AU12
I_e = 16 A (resistive loads)
4 A (inductive loads) at 250 Vac.



Terminal shrouds (2 units)
A B C D
TOP DS-CU38 DS-CU30 DS-CU30
BOTTOM DS-CU39 DS-CU31 DS-CU38

TThe shrouds can only be fitted in the front switch.



Bridging links (2 or 3 units)
A B CODE DS-PI320U C D CODE DS-PI330U
A B CODE DS-PI370U C D CODE DS-PI360U

Dimensions (mm)

Panel drilling for panel handle

S max (Cu)	H max (Cu)	L max (Cu)	M
mm ²	mm	mm	Nxm
2x300	2x10	50	M14 45

S5000M DC Switch - disconnecter for DC current 8P (multi-string)

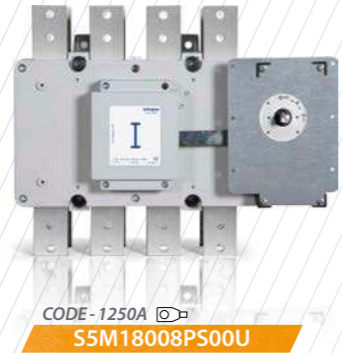

Size 4

A 1250

1000Vdc

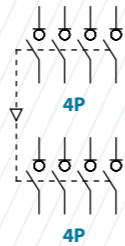

Technical information



According to IEC/EN 60947-3
GB14048.3

Rated thermal current in ambient at	I _{th}	40° C	A	1250
		50° C	A	1250
		60° C	A	1250
Rated insulation voltage DC20	U _i	V	1500	
Rated dielectric strength	50 Hz, 1 min.	V	10000	
Rated impulse withstand voltage	U _{imp}	kV	12	
Rated operational current ^{*(1)} DC21B	I _e	U _e		
		400 Vdc	A	1250
		600 Vdc	A	1250
		800 Vdc	A	1250
		1000 Vdc	A	1250

^{*(1)} Other voltages and / or utilization categories. Please consult
^{*(2)} Without limiting protective device (short-circuit maintained 50... 100 ms.)
^{*(3)} Please consult us for more operations

Connection diagram

Connection diagram

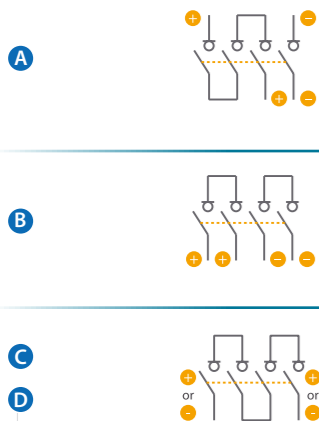

Bridging links
Front switch Rear switch

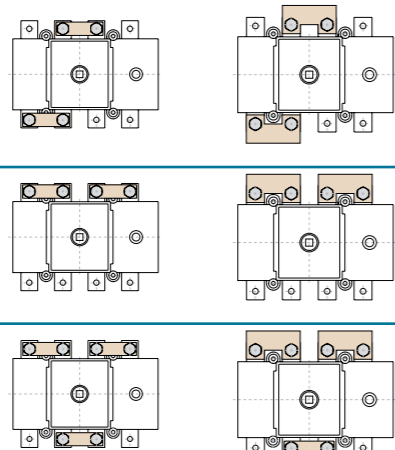

Terminal shrouds
(On front switch only)

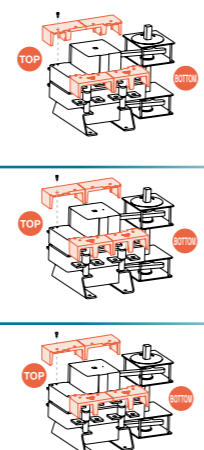

tests:



Short - circuit behaviour			
Short - circuit making capacity ^{*(2)}	I _{cm}	kA (peak)	60
Minimum number of mechanical operations ^{*(3)}		Cycles	10000
Minimum number of electrical operations	DC21B 1000Vdc	Cycles	100
Maximum weight		Kg	47,3

Accessories



» Direct handle
CODE DS-LI41



» Panel handle included shaft ^{*(e1)}
IP65|UL50E/NEMA 250
Types: 1, 3R, 4, 4X y 12
CODE DS-LA41



» Panel handle without shaft
IP65|UL50E/NEMA 250
Types: 1, 3R, 4, 4X y 12
CODE DS-LA43

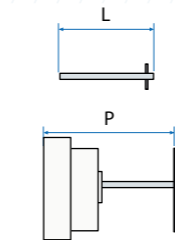

» Shafts
Standard shaft included ^{*(e1)}
L (mm) | P (mm)
239 | 408... 573



» Auxiliary contacts
1NO+1NC CODE DS-AU11
2NO+2NC CODE DS-AU12
I_e = 16 A (resistive loads)
4 A (inductive loads) at 250 Vac.



» Terminal shrouds (2 units)

	A	B	C D
TOP	DS-CU48	DS-CU40	DS-CU40
BOTTOM	DS-CU49	DS-CU41	DS-CU48

The shrouds can only be fitted in the front switch.



» Bridging links (2 or 3 units)

	A B	CODE DS-PI420U	C D	CODE DS-PI430U
	A B	CODE DS-PI470U	C D	CODE DS-PI460U

Dimensions (mm)

Panel drilling for panel handle

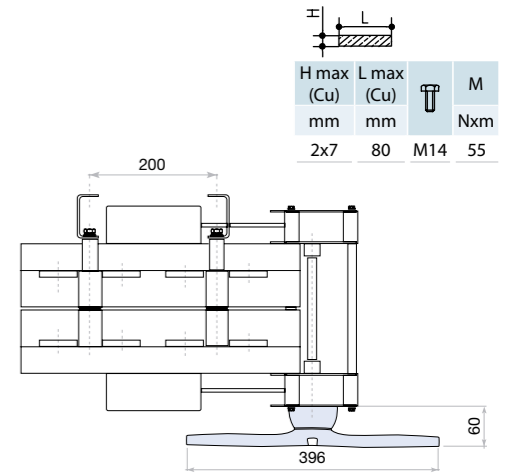
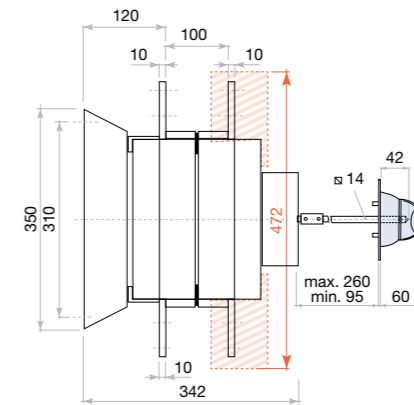
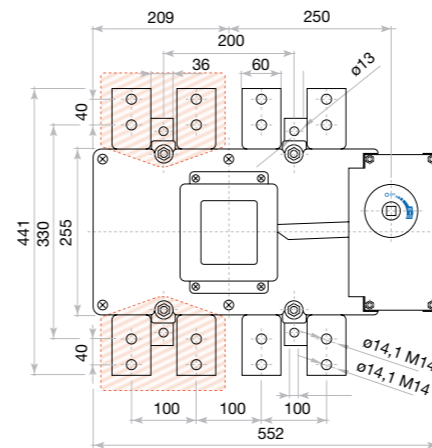
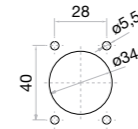



S5000M DC Switch - disconnecter for DC current 3P+3P 4P+4P

Size 1
A 200|315
 1500Vdc

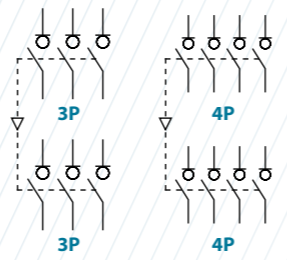
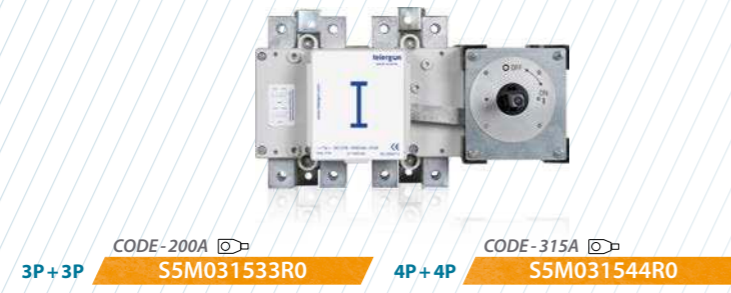

Technical information



According to IEC-EN 60947-1
 IEC-EN 60947-3

			3+3	4+4
Rated thermal current in ambient at	40° C	A	200	315
	50° C	A	200	315
	60° C	A	200	315
Rated insulation voltage DC20	Ui	V	1500	1500
Rated dielectric strength	50 Hz., 1 min.	V	5000	5000
Rated impulse withstand voltage	Uimp	kV	8	8
Rated operational current	le	DC21B 1500 Vdc	A 200	315
Rated making capacity	4+4	DC21 1500 Vdc	A -	315

Short - circuit behaviour			
Maximum cut - off current ^{*(1)}	lcm	kA (peak)	20
Short - time withstand current (1 sec.)	lcw	kA rms	12
Conditional short - circuit current (rms value) ^{*(2)}		kA rms	100
Maximum cut - off current (peak value)		kA (peak)	33
Maximum power dissipation	A ² s (x10 ³)		1000
Minimum number of mechanical operations	Cycles		20000
Minimum number of electrical operations	DC21B 1500 Vdc	Cycles	200
Maximum weight 3+3		Kg	5,5
Maximum weight 4+4		Kg	5,8

^{*(1)} Without limiting protective device (short-circuit maintained 50... 100 ms.)
^{*(2)} With limiting protective device which set a limit to peak value short-circuit making capacity and maximum power dissipation to indicated values

Connection diagram

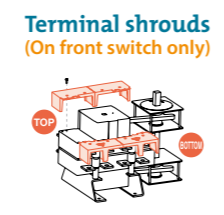
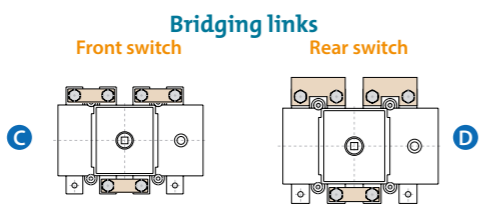
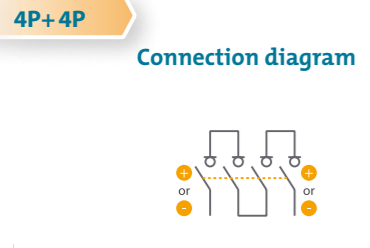
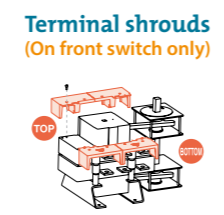
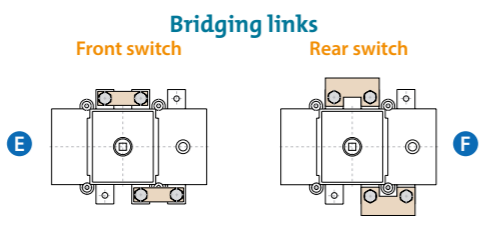
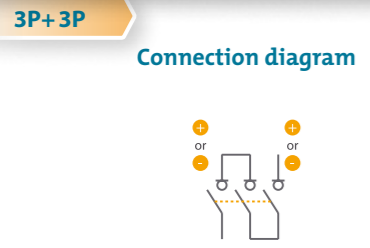

Accessories

- Direct handle**
CODE DS-LI12
- Panel handle** included shaft ^{*(e1)}
IP65|UL50E/NEMA 250
Types: 1, 3R, 4, 4X y 12
CODE DS-LA12
- Panel handle** without shaft
IP65|UL50E/NEMA 250
Types: 1, 3R, 4, 4X y 12
CODE DS-LA15
- Shafts**
Standard shaft included ^{*(e1)}
L (mm) | P (mm)
227 | 288... 422
- Auxiliary contacts**
1NO+1NC CODE DS-AU11
2NO+2NC CODE DS-AU12
le = 16 A (resistive loads)
4 A (inductive loads) at 250 Vac.
- Terminal shrouds** (2 units)
E | C
TOP DS-CU180U | DS-CU100U
BOTTOM DS-CU100U | DS-CU180U
The shrouds can only be fitted in the front switch.
- Bridging links** (2 or 3 units)
3P+3P | 4P+4P
E | C | DS-PI120U | DS-PI130U
F | D | DS-PI170U | DS-PI160U

Dimensions (mm)

Panel drilling for panel handle

S max (Cu)	H max (Cu)	L max (Cu)	T	M
mm ²	mm	mm		Nxm
185	7	25	M10	18

S5000M DC Switch - disconnecter for DC current 3P+3P 4P+4P

Size 2
A 400|500
1500Vdc

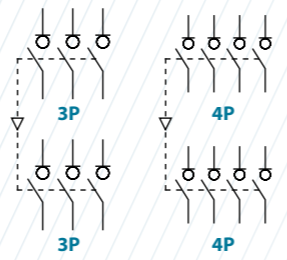

Accessories

- Direct handle**
CODE DS-LI22
- Panel handle** included shaft ^{*(e1)}
IP65|UL50E/NEMA 250
Types: 1, 3R, 4, 4X y 12
CODE DS-LA22
- Shafts**
Standard shaft included ^{*(e1)}
L (mm) | P (mm)
239 | 325... 490
- Auxiliary contacts**
1NO+1NC CODE DS-AU11
2NO+2NC CODE DS-AU12
I_e = 16 A (resistive loads)
4 A (inductive loads) at 250 Vac.
- Terminal shrouds** (2 units)
E DS-CU280U | C DS-CU200U
TOP DS-CU280U | BOTTOM DS-CU200U
The shrouds can only be fitted in the front switch.
- Bridging links** (2 or 3 units)
3P+3P | 4P+4P
E DS-PI220U | C DS-PI230U
F DS-PI270U | D DS-PI260U

Technical information



According to IEC-EN 60947-1
IEC-EN 60947-3

			3+3	4+4
Rated thermal current in ambient at	I _{th}	40° C	A 400	500
		50° C	A 400	500
		60° C	A 400	500
Rated insulation voltage DC20	U _i	V	1500	1500
Rated dielectric strength		50 Hz., 1 min.	V 8000	8000
Rated impulse withstand voltage	U _{imp}	kV	12	12
Rated operational current	I _e	DC21B 1500 Vdc	A 400	500
Rated making capacity		4+4 DC21 1500 Vdc	A -	500

Short - circuit behaviour			
Maximum cut - off current ^{*(1)}	I _{cm}	kA (peak)	26
Short - time withstand current (1 sec.)	I _{cw}	kA rms	16
Conditional short - circuit current (rms value) ^{*(2)}		kA rms	100
Maximum cut - off current (peak value)		kA (peak)	39
Maximum power dissipation		A ² s (x10 ³)	1600
Minimum number of mechanical operations		Cycles	10000
Minimum number of electrical operations	DC21B 1500 Vdc	Cycles	200
Maximum weight 3+3		Kg	12,3
Maximum weight 4+4		Kg	13

^{*(1)} Without limiting protective device (short-circuit maintained 50... 100 ms.)
^{*(2)} With limiting protective device which set a limit to peak value short-circuit making capacity and maximum power dissipation to indicated values

Connection diagram

3P+3P

Connection diagram

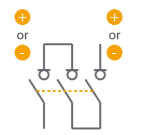

Bridging links

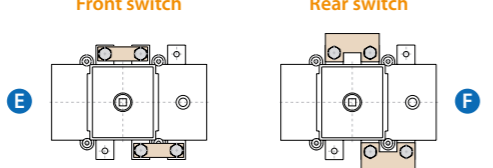

Terminal shrouds (On front switch only)

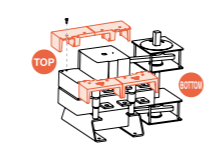

4P+4P

Connection diagram



Bridging links

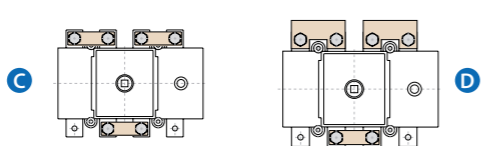

Terminal shrouds (On front switch only)

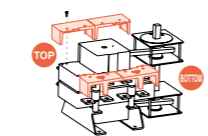

Dimensions (mm)

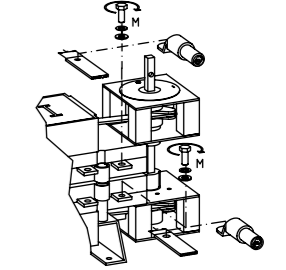
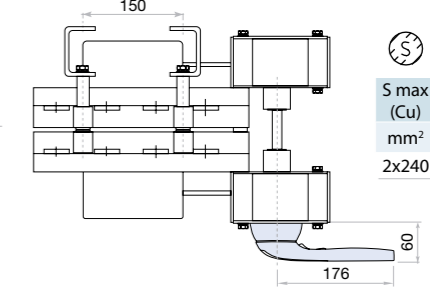
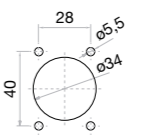
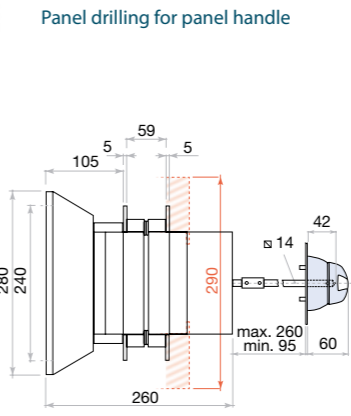
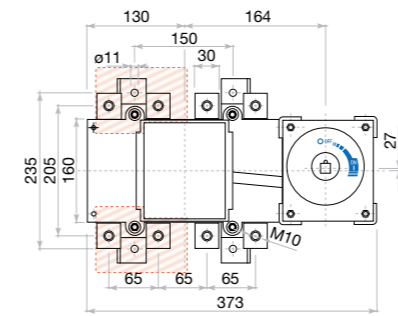

S max (Cu) mm ²	H max (Cu) mm	L max (Cu) mm	T M
2x240	2x5	40	M10 24

S5000M DC Switch - disconnecter for DC current 3P+3P 4P+4P

Size 3
A 600|800
1500Vdc

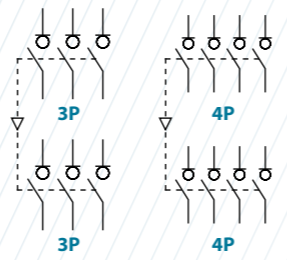

Technical information



According to IEC-EN 60947-1
IEC-EN 60947-3

		3+3		4+4	
Rated thermal current in ambient at	lth	40° C	A	600	800
		50° C	A	600	800
		60° C	A	600	800
Rated insulation voltage DC20	Ui	V	1500	1500	
Rated dielectric strength	50 Hz., 1 min.	V	8000	8000	
Rated impulse withstand voltage	Uimp	kV	12	12	
Rated operational current	le	DC21B 1500 Vdc	A	600	800
Rated making capacity	4+4	DC21 1500 Vdc	A	-	800

*⁽¹⁾ Without limiting protective device (short-circuit maintained 50... 100 ms.)
*⁽²⁾ With limiting protective device which set a limit to peak value short-circuit making capacity and maximum power dissipation to indicated values

tests:

Short - circuit behaviour			
Maximum cut - off current * ⁽¹⁾	lcm	kA (peak)	60
Short - time withstand current (1 sec.)	lcw	kA rms	25
Conditional short - circuit current (rms value) * ⁽²⁾		kA rms	72
Maximum cut - off current (peak value)		kA (peak)	55
Maximum power dissipation		A ² s (x10 ³)	4900
Minimum number of mechanical operations		Cycles	10000
Minimum number of electrical operations	DC21B 1500Vdc	Cycles	200
Maximum weight 3+3		Kg	18,5
Maximum weight 4+4		Kg	20

Connection diagram

3P+3P

Connection diagram

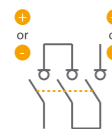

Bridging links

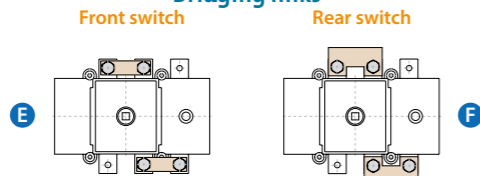

Terminal shrouds (On front switch only)

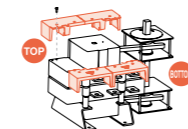

4P+4P

Connection diagram



Bridging links

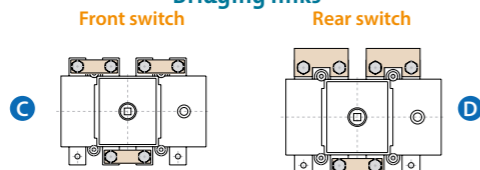

Terminal shrouds (On front switch only)

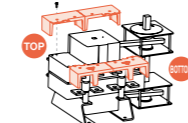

Accessories



Direct handle
CODE DS-LI41



Panel handle included shaft *^(e1)
IP65|UL50E/NEMA 250
Types: 1, 3R, 4, 4X y 12
CODE DS-LA41



Panel handle without shaft
IP65|UL50E/NEMA 250
Types: 1, 3R, 4, 4X y 12
CODE DS-LA43

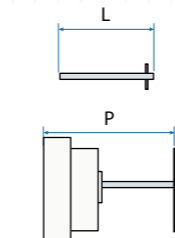

Shafts
Standard shaft included *^(e1)
L (mm) | P (mm)
239 | 408... 573



Auxiliary contacts
1NO+1NC CODE DS-AU11
2NO+2NC CODE DS-AU12
le = 16 A (resistive loads)
4 A (inductive loads) at 250 Vac.



Terminal shrouds (2 units)
E C
TOP DS-CU380U | DS-CU300U
BOTTOM DS-CU300U | DS-CU380U

The shrouds can only be fitted in the front switch.



Bridging links (2 or 3 units)
3P+3P | 4P+4P
E DS-PI320U | C DS-PI330U
F DS-PI370U | D DS-PI360U

Dimensions (mm)

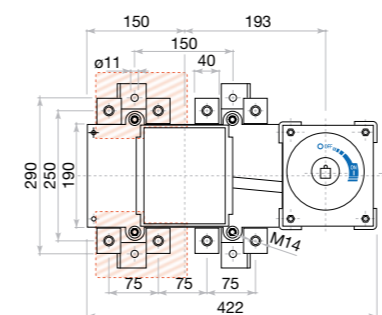

Panel drilling for panel handle

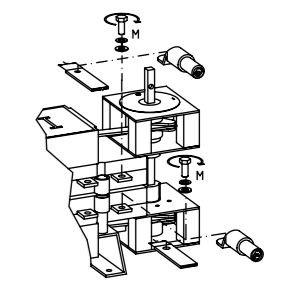
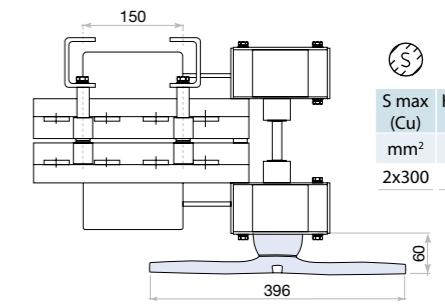
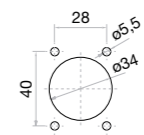
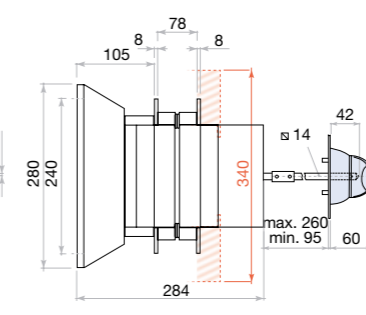

S max (Cu)	H max (Cu)	L max (Cu)	M
2x300	2x10	50	M14 45



S5000M DC Switch - disconnecter for DC current 3P+3P 4P+4P

Size 4
A 1000|1250
 1500Vdc

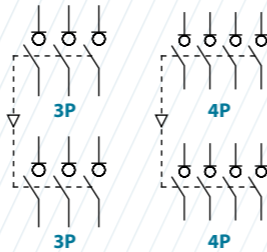
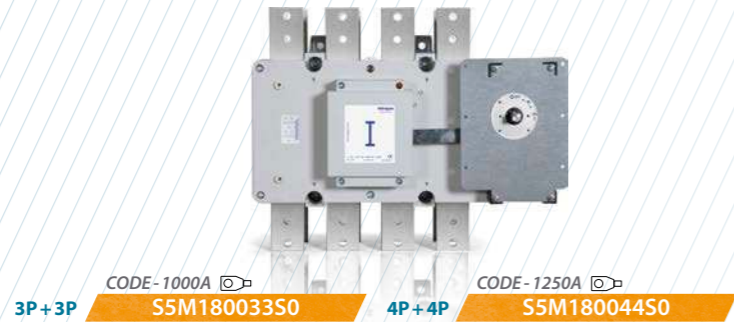

Technical information



According to IEC-EN 60947-1
 IEC-EN 60947-3

		3+3		4+4	
Rated thermal current in ambient at	40° C	A	1000	1250	
	50° C	A	1000	1250	
	60° C	A	1000	1250	
Rated insulation voltage DC20	Ui	V	1500	1500	
Rated dielectric strength	50 Hz., 1 min.	V	10000	10000	
Rated impulse withstand voltage	Uimp	kV	12	12	
Rated operational current	le	DC21B 1500 Vdc	A	1000	1250
Rated making capacity	4+4	DC21 1500 Vdc	A	-	1250

*⁽¹⁾ Without limiting protective device (short-circuit maintained 50... 100 ms.)

Short - circuit behaviour

Maximum cut - off current ⁽¹⁾	Icm	kA (peak)	75
Short - time withstand current (1 sec.)	Icw	kA rms	50
Minimum number of mechanical operations		Cycles	10000
Minimum number of electrical operations	DC21B 1500V	Cycles	100
Maximum weight 3+3		Kg	42,9
Maximum weight 4+4		Kg	47,3

Connection diagram

3P+3P

Connection diagram

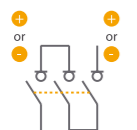

Bridging links

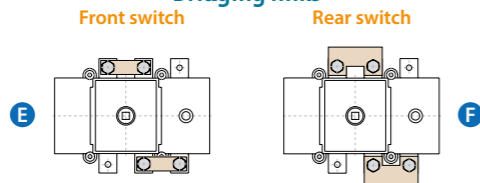

Terminal shrouds (On front switch only)

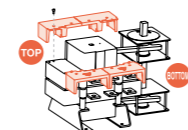

4P+4P

Connection diagram



Bridging links



Terminal shrouds (On front switch only)

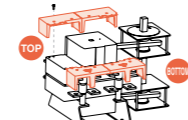

Accessories



Direct handle
 CODE DS-LI41



Panel handle included shaft ^(e1)
 IP65|UL50E/NEMA 250
 Types: 1, 3R, 4, 4X y 12
 CODE DS-LA41



Panel handle without shaft
 IP65|UL50E/NEMA 250
 Types: 1, 3R, 4, 4X y 12
 CODE DS-LA43

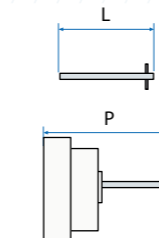

Shafts
 Standard shaft included ^(e1)
 L (mm) | P (mm)
 239 | 408... 573

Dimensions (mm)

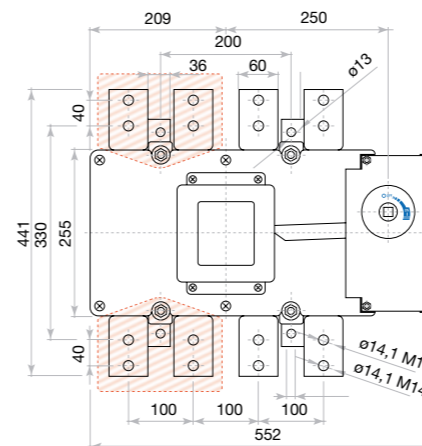

Panel drilling for panel handle

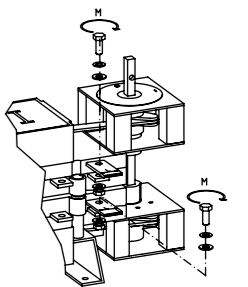
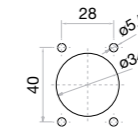
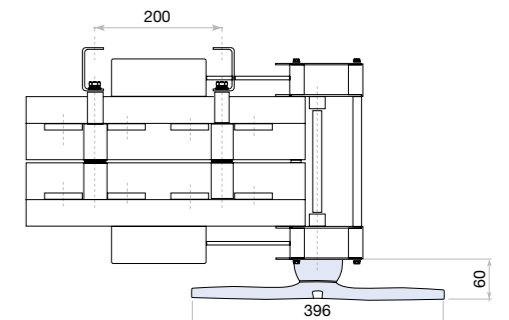
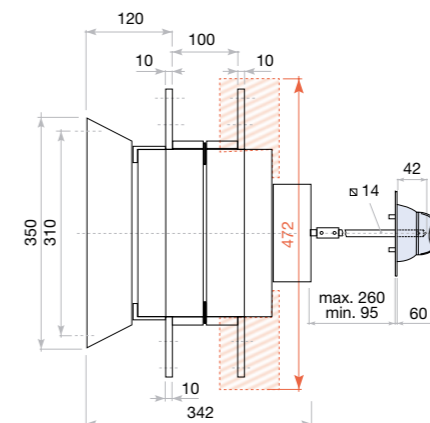

H max (Cu)	L max (Cu)	T	M
mm	mm	Nxm	
2x7	80	M14	55

Auxiliary contacts
 1NO+1NC CODE DS-AU11
 2NO+2NC CODE DS-AU12
 Ie = 16 A (resistive loads)
 4 A (inductive loads) at 250 Vac.

Terminal shrouds (2 units)
 3P+3P 4P+4P
 E C
 TOP DS-CU480U DS-CU400U
 BOTTOM DS-CU400U DS-CU480U

The shrouds can only be fitted in the front switch.

Bridging links (2 or 3 units)
 3P+3P 4P+4P
 E C
 F D
 DS-PI420U DS-PI430U
 DS-PI470U DS-PI460U

S6000 DC Switch - disconnecter base mounting 1P - 2P

Size 1
A 125|160|200|250|315|400
 500 - 750 - 1000Vdc

CODE - 500Vdc

125A	S6-0125__S0
160A	S6-0160__S0
200A	S6-0200__S0
250A	S6-0250__S0
315A	S6-0315__S0
400A	S6-0400__D0

CODE - 750Vdc

125A	S6-0125__S0
160A	S6-0160__S0
200A	S6-0200__S0
250A	S6-0250__S0
315A	S6-0315__S0
400A	S6-0400__D0

CODE - 1000Vdc

125A	S6-0125__S0
160A	S6-0160__S0
200A	S6-0200__S0
250A	S6-0250__S0
315A	S6-0315__S0
400A	S6-0400__D0

Wiring diagrams for configurations: 2L, 2G, 2H, 2J, 2K, 2A, 2C, 2B, 2D, 2E, 2F, 2X, 2Y, 1M, 1Q, 1V, 1W.

Accessories

- Direct handle**
CODE DS-SI11
- Panel handle** included shaft ^(e1)
IP65|UL50E/NEMA 250
Types: 1, 3R, 4, 4X y 12
CODE DS-SA11
- Panel handle** without shaft
IP65|UL50E/NEMA 250
Types: 1, 3R, 4, 4X y 12
CODE DS-SA14
- Terminal shrouds**
CODE DR-CU11 (1 unit)
CODE DR-CU12 (1 unit)
CODE DR-CU13 (1 unit)
- Phase barriers**
CODE DR-SF11 (1 unit)
CODE DR-SF12 (2 units)
CODE DR-SF13 (3 units)
- Spacers**
CODE DR-EL11 (4 units)
- Safety key lock device**
Simple CODE DS-CA11
Double CODE DS-CE11
For external handle, lock the handle by means of a key in position "OFF" (under request, in "ON"), the key can only be removed with the handle locked.
- Shafts**
Standard shaft included ^(e1)
L (mm) | P (mm) | CODE
227 | 103... 256 |
Shaft extensions
Type 1
L (mm) | P (mm) | CODE
375 | 103... 415 | DS-EP14
Type 2
L (mm) | P (mm) | CODE
536 | 103... 576 | DS-EP15
- Auxiliary contacts**
1NO+1NC CODE D5LAU01
2NO+2NC CODE D5LAU02
Ie = 16 A (resistive loads)
4 A (inductive loads) at 250 Vac.

Dimensions (mm)

Panel drilling for panel handle

Size	S max (Cu) mm ²	H max (Cu) mm	L max (Cu) mm	T	M
125 A	95	5	25	M10	18
160 A	95	5	25	M10	18
200 A	120	7	25	M10	18
250 A	150	7	25	M10	18
315 A	185	7	25	M10	18
400 A	240 ⁽⁵⁾	7	35 ⁽⁵⁾	M10	18

⁽⁵⁾ Using phase barriers DR-SF__ to maintain the required clearance.

Technical information



According to IEC/EN 60947-1
IEC/EN 60947-3

		125	160	200	250	315	400
Rated thermal I _{th} current in ambient at	40° C	A 125	160	200	250	315	400
	50° C	A 125	160	200	250	315	400
	60° C	A 125	160	200	250	315	400
Rated insulation voltage (DC)	Ui	V 1500	1500	1500	1500	1500	1500
Rated dielectric strength	50 Hz, 1 min.	V 5000	5000	5000	5000	5000	5000
Rated impulse withstand voltage	U _{imp}	kV 12	12	12	12	12	12
Rated operational current ⁽¹⁾ I _e	Code 500Vdc	A 125	160	200	250	315	400
	Code 750Vdc DC21B	A 125	160	200	250	315	400
	Code 1000Vdc	A 125	160	200	250	315	400

		125	160	200	250	315	400
Short - circuit behaviour							
Rated short-circuit making capacity ⁽²⁾	I _{cm} kA (peak)	10	10	10	10	10	10
Rated short-time withstand current (1sec)	I _{cw} kA rms	10	10	10	10	10	10
Conditional short - circuit current ⁽³⁾	kA rms	100	100	100	100	100	100
Mechanical features							
Minimum number of mechanical operations ⁽⁴⁾	Cycles	20000	20000	20000	20000	20000	20000
Maximum weight		Consult according to code					

⁽¹⁾ Other voltages and / or utilization categories. Please consult
⁽²⁾ Without limiting protective device (short-circuit maintained 50... 100 ms.)
⁽³⁾ With limiting protective device which set a limit to peak value short-circuit making capacity and maximum power dissipation to indicated values
⁽⁴⁾ Please consult us for more operations

S6000 DC UL Switch - disconnecter base mounting 1P - 2P

Size 1
A 250
 500 - 750 - 1000Vdc

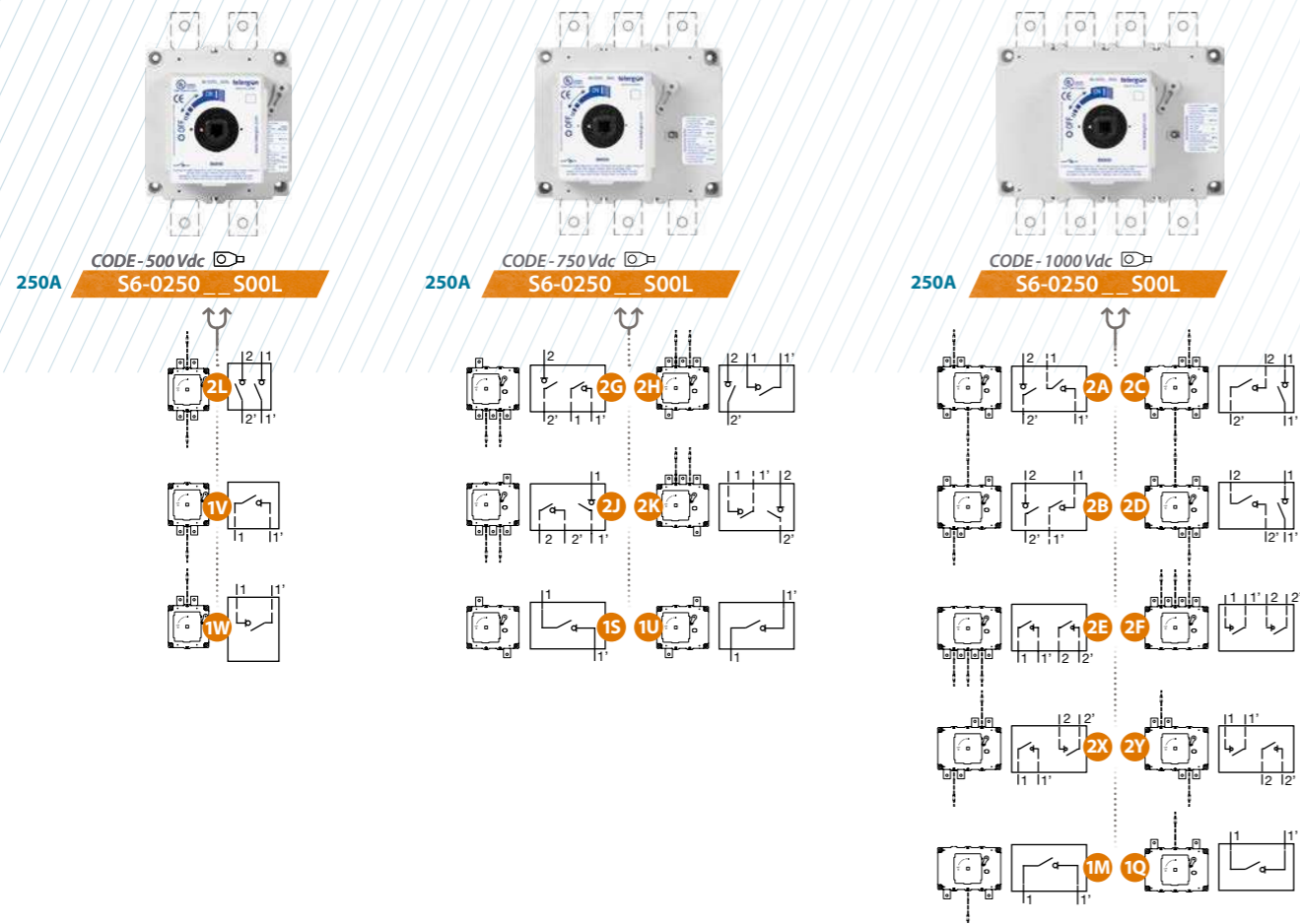

Accessories

- Direct handle**
CODE DS-SI11
- Panel handle** included shaft *(e1)
IP65|UL50E/NEMA 250
Types: 1, 3R, 4, 4X y 12
CODE DS-SA11
- Panel handle** without shaft
IP65|UL50E/NEMA 250
Types: 1, 3R, 4, 4X y 12
CODE DS-SA14
- Terminal shrouds**
CODE DR-CU11 (1 unit)
CODE DR-CU12 (1 unit)
CODE DR-CU13 (1 unit)
- Phase barriers**
CODE DR-SF11 (1 unit)
CODE DR-SF12 (2 units)
CODE DR-SF13 (3 units)
- Spacers**
CODE DR-EL11 (4 units)
- Terminal lug**
CODE DR-TL11 (2 units)
(Using phase barriers DR-SF__ to maintain the required clearance)
- Shafts**
Standard shaft included *(e1)
L (mm) | P (mm) |
227 | 103... 256
Shaft extensions
Type 1
L (mm) | P (mm) | CODE
375 | 103... 415 | DS-EP14
Type 2
L (mm) | P (mm) | CODE
536 | 103... 576 | DS-EP15
- Auxiliary contacts**
1NO+1NC CODE D5LAU01
2NO+2NC CODE D5LAU02
Ie = 16 A (resistive loads)
4 A (inductive loads) at 250 Vac.

Dimensions (mm)

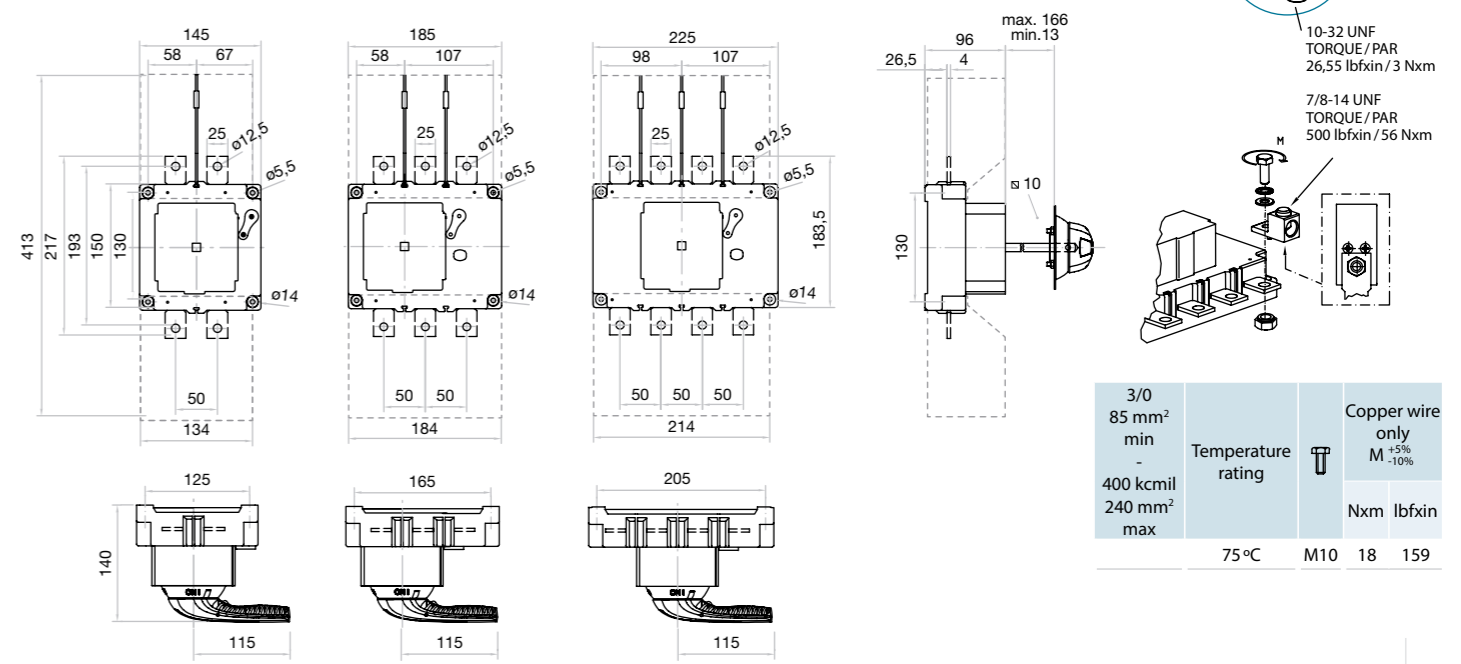

Technical information



tests: **AIT** AUSTRIAN INSTITUTE OF TECHNOLOGY TOMORROW TODAY

According to UL98B

LISTED E333311				250
Rated thermal current	I _{th}	-20°C to +50°C	A	250
Ampere - Rating	Code	500Vdc	A	250
		750Vdc	A	250
		1000Vdc	A	250
Rated short-circuit current	I _{cc}		kA	10
Overload				
Number of operations on overload (2xI _e)			Cycles	25
Endurance				
Number of electrical operations			Cycles	400
Maximum weight			Consult according to code	
Wiring capacity				
Minimum connection wire range/AWG		MCM		400
Maximum connection wire range/AWG		MCM		400

250 A
 Conforms to UL98B. Minus 20 to +50°C. PV disconnects switch. Location Category B 1000Vdc 250 A Torque: 159 lbf-in. Short circuit rating: 10 kA
 Suitable for Use in PV Systems in accordance with Article 690 of the NEC IEC-60947-3 Uimp 12kV DC21B-1000Vdc-250A Ui 1500Vdc Ith 250 A

3/0 85 mm ² min	Temperature rating	Copper wire only M +5% -10%
400 kcmil 240 mm ² max		
	75°C	M10 18 159





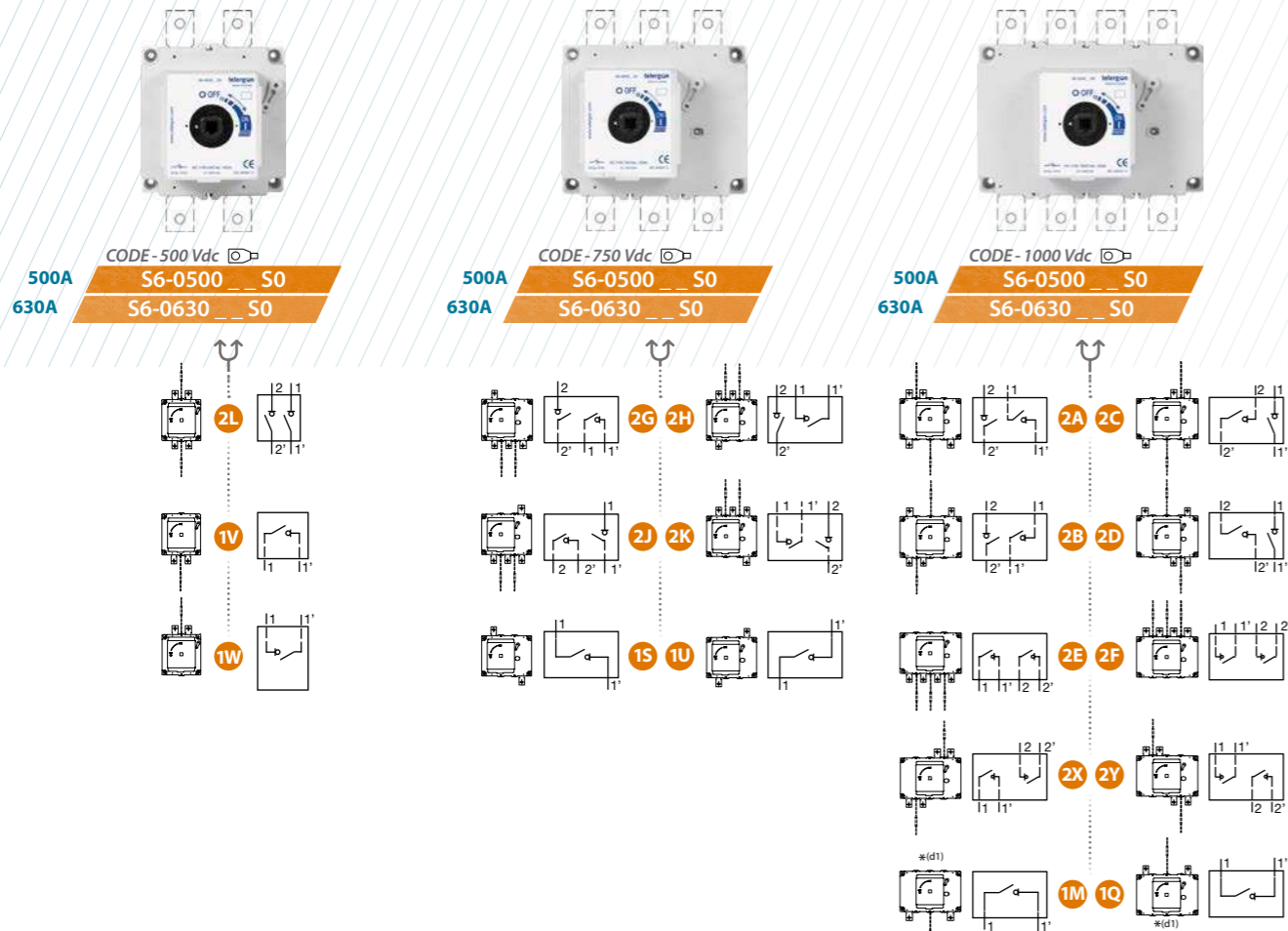

S6000 DC Switch - disconnecter base mounting 1P - 2P

Size 2
A 500|630
500 - 750 - 1000Vdc



*[d1] Only for 500 A.

Accessories

- 
>> Direct handle
 CODE DS-LI21
- 
>> Panel handle included shaft ^{*(e1)}
 IP65|UL50E/NEMA 250
 Types: 1, 3R, 4, 4X y 12
 CODE DS-LA21
- 
>> Panel handle without shaft
 IP65|UL50E/NEMA 250
 Types: 1, 3R, 4, 4X y 12
 CODE DS-LA24
- 
>> Terminal shrouds
 CODE DR-CU21 (1 unit)
 CODE DR-CU22 (1 unit)
 CODE DR-CU23 (1 unit)
- 
>> Phase barriers
 CODE DR-SF21 (1 unit)
 CODE DR-SF22 (2 units)
 CODE DR-SF23 (3 units)
- 
>> Spacers
 CODE DR-EL21 (4 units)
- 
>> Safety key lock device
 Simple CODE DS-CB21
 Double CODE DS-CF21

 For external handle, lock the handle by means of a key in position "OFF" (under request, in "ON"), the key can only be removed with the handle locked

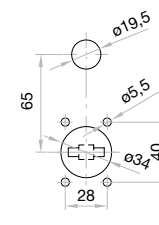
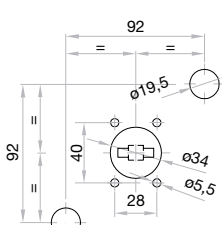
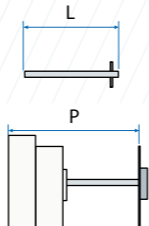
 Panel drilling for handle and keylock device
 Simple  Double 
- 
>> Shafts
Standard shaft included ^{*(e1)}
 L (mm) | P (mm) |
 195 | 134... 240 |

Shaft extensions
 Type 1
 L (mm) | P (mm) | CODE |
 345 | 134... 400 | DS-EP23 |

 Type 2
 L (mm) | P (mm) | CODE |
 535 | 134... 560 | DS-EP24 |
- 
>> Auxiliary contacts
 1NO+1NC CODE D5LAU01
 2NO+2NC CODE D5LAU02

 Ie = 16 A (resistive loads)
 4 A (inductive loads) at 250 Vac.

Dimensions (mm)

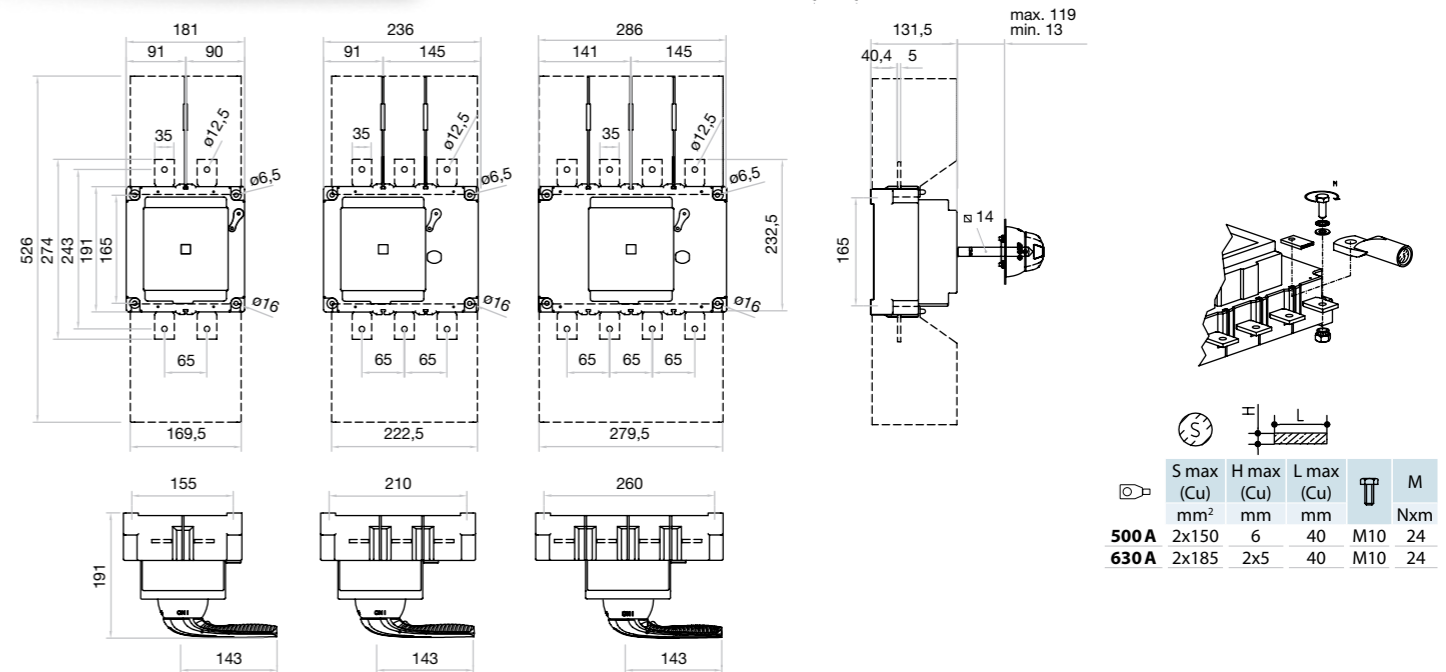

Technical information



tests: **AIT** AUSTRIAN INSTITUTE OF TECHNOLOGY TOMORROW TODAY

According to IEC/EN 60947-1
IEC/EN 60947-3

			500	630
Rated thermal current in ambient at	I _{th}	40° C	A 500	630
		50° C	A 500	630
		60° C	A 500	630
Rated insulation voltage (DC)	U _i	V	1500	1500
Rated dielectric strength		50 Hz, 1 min.	V 8000	8000
Rated impulse withstand voltage	U _{imp}	kV	12	12
Rated operational current ^{*(1)} I _e		Code 500Vdc	A 500	630
		Code 750Vdc DC21B	A 500	630
		Code 1000Vdc	A 500	630

			500	630
Short - circuit behaviour				
Rated short-circuit making capacity ^{*(2)}	I _{cm}	kA (peak)	10	10
Rated short-time withstand current (1sec)	I _{cw}	kA rms	10	10
Conditional short - circuit current ^{*(3)}		kA rms	100	100
Mechanical features				
Minimum number of mechanical operations ^{*(4)}		Cycles	10000	10000
Maximum weight		Consult according to code		

^{*(1)} Other voltages and / or utilization categories. Please consult

^{*(2)} Without limiting protective device (short-circuit maintained 50... 100 ms.)

^{*(3)} With limiting protective device which set a limit to peak value short-circuit making capacity and maximum power dissipation to indicated values

^{*(4)} Please consult us for more operations

S6000 DC UL Switch - disconnecter base mounting 1P - 2P

Size 2
A 400
 500 - 750 - 1000Vdc

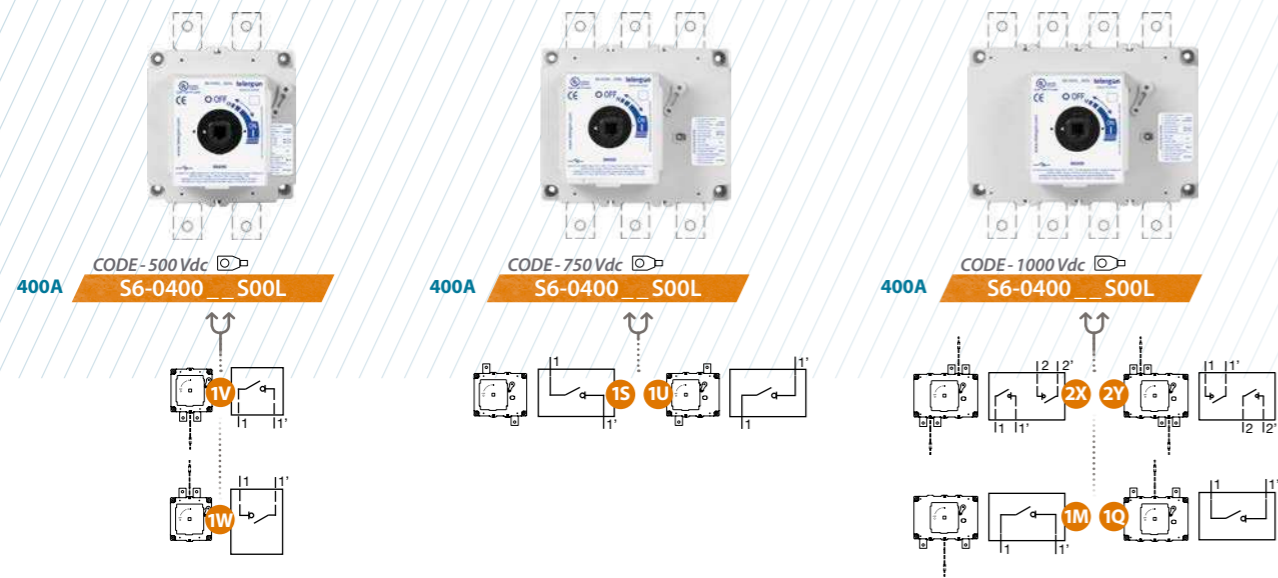

Accessories

- Direct handle**
CODE DS-LI21
- Panel handle** included shaft ^{*(e1)}
IP65 | UL50E/NEMA 250
Types: 1, 3R, 4, 4X y 12
CODE DS-LA21
- Panel handle** without shaft
IP65 | UL50E/NEMA 250
Types: 1, 3R, 4, 4X y 12
CODE DS-LA24
- Terminal shrouds**
CODE DR-CU21 (1 unit)
CODE DR-CU22 (1 unit)
CODE DR-CU23 (1 unit)
- Phase barriers**
CODE DR-SF21 (1 unit)
CODE DR-SF22 (2 units)
CODE DR-SF23 (3 units)
- Spacers**
CODE DR-EL21 (4 units)
- Terminal lug**
CODE DR-TL21 (2 units)
CODE DR-TL22 (2 units)
(Using phase barriers DR-SF__ to maintain the required clearance)
- Shafts**

Standard shaft included ^{*(e1)}		
L (mm)	P (mm)	CODE
195	134... 240	
Shaft extensions		
Type 1		
L (mm)	P (mm)	CODE
345	134... 400	DS-EP23
Type 2		
L (mm)	P (mm)	CODE
535	134... 560	DS-EP24
- Auxiliary contacts**
 1NO+1NC CODE D5LAU01
 2NO+2NC CODE D5LAU02
 Ie = 16 A (resistive loads)
 4 A (inductive loads) at 250 Vac.

Technical information



tests: **AIT** AUSTRIAN INSTITUTE OF TECHNOLOGY TOMORROW TODAY

According to UL98 B

LISTED E333311			
Rated thermal current	Ith	-20°C to +50°C	A 400
Rated operational current	Ie	Code 500Vdc	A 400
		Code 750Vdc	A 400
		Code 1000Vdc	A 400
Rated short-circuit current	Icc	kA	10
Overload			
Number of operations on overload (2xIe)		Cycles	25
Endurance			
Number of electrical operations		Cycles	400
Maximum weight		Consult according to code	
Wiring capacity			
Minimum connection wire range/AWG		MCM	2x300
Maximum connection wire range/AWG		MCM	2x350

400 A
 Conforms to UL98B. Minus 20 to +50°C. PV disconnects switch. Location Category B
 1000 Vdc 400 A Torque: 212 lbf.in. Short circuit rating: 10 kA
 Suitable for Use in PV Systems in accordance with Article 690 of the NEC
 IEC-60947-3 Uimp 12 kV DC21B - 1000 Vdc - 400 A Ui 1500 Vdc Ith 400 A

Dimensions (mm)

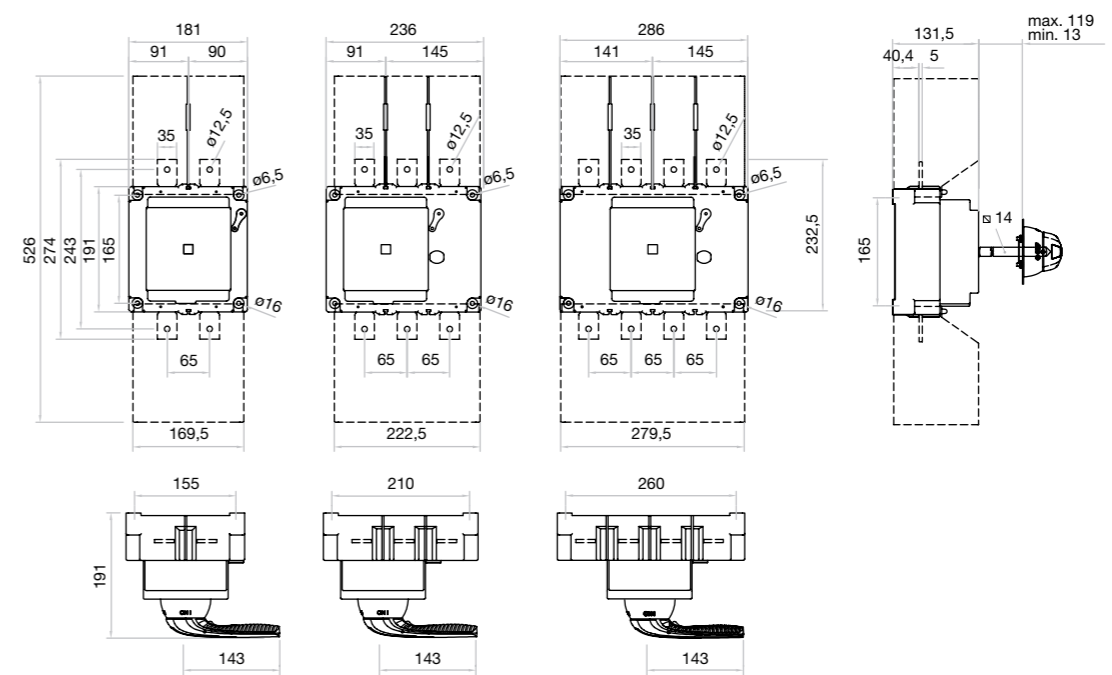

Panel drilling for panel handle

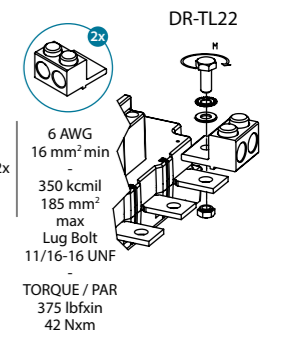
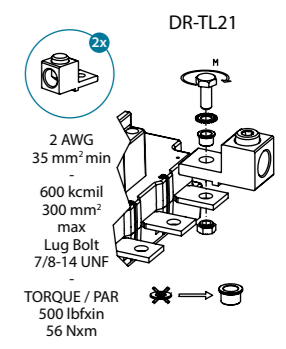
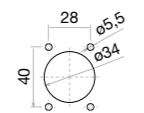

Temperature rating	Copper wire only M ±5% Nxm lbf.in	75°C	M10	24	212
--------------------	---	------	-----	----	-----

S6000N DC Switch - disconnecter base mounting 1P - 1P

Size 1
A 315|400
1500Vdc



315A
400A

CODE-1500 Vdc
S6N0315MMS0
S6N0400MMD0

CODE-1500 Vdc
S6N0315QQS0
S6N0400QQD0

CODE-1500 Vdc
S6N0315MQS0
S6N0400MQD0

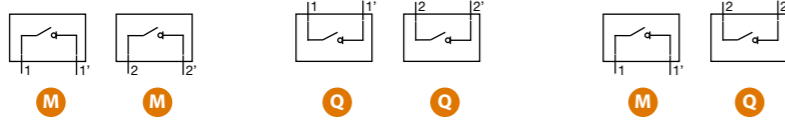

Technical information



tests: **AIT** AUSTRIAN INSTITUTE OF TECHNOLOGY TOMORROW TODAY

According to IEC/EN 60947-1
IEC/EN 60947-3

			315	400
Rated thermal current in ambient at	Ith	40° C	A 315	400
		50° C	A 315	400
		60° C	A 315	360
Rated insulation voltage (DC)	Ui	V	1500	1500
Rated dielectric strength		50 Hz., 1 min.	V 5000	5000
Rated impulse withstand voltage		Uimp	kV 12	12
Rated operational current ^{*(1)}	Ie	1500Vdc DC21B A	315	400

			315	400
Short - circuit behaviour				
Rated short-circuit making capacity ^{*(2)}	Icm	kA (peak)	10	10
Rated short-time withstand current (1sec)	Icw	kA rms	10	10
Conditional short - circuit current ^{*(3)}		kA rms	100	100
Mechanical features				
Minimum number of mechanical operations ^{*(4)}	Cycles		8000	8000
Maximum weight			4,25	4,29

^{*(1)} Other voltages and / or utilization categories. Please consult
^{*(2)} Without limiting protective device (short-circuit maintained 50... 100 ms.)
^{*(3)} With limiting protective device which set a limit to peak value short-circuit making capacity and maximum power dissipation to indicated values
^{*(4)} Please consult us for more operations

Accessories

Direct handle
CODE DS-SI11

Panel handle included shaft ^{*(e1)}
IP65|UL50E/NEMA 250
Types: 1, 3R, 4, 4X y 12
CODE DS-SA11

Panel handle without shaft
IP65|UL50E/NEMA 250
Types: 1, 3R, 4, 4X y 12
CODE DS-SA14

Auxiliary contacts
1NO+1NC CODE D5LAU01
2NO+2NC CODE D5LAU02

Ie = 16 A (resistive loads)
4 A (inductive loads) at 250 Vac.

Shafts
Standard shaft included ^{*(e1)}
L (mm) | P (mm)
227 | 179... 398,5

Shaft extensions
Type 1
L (mm) | P (mm) | CODE
375 | 179... 398,5 | DS-EP14

Type 2
L (mm) | P (mm) | CODE
536 | 179... 707,5 | DS-EP15

Dimensions (mm)

Panel drilling for panel handle

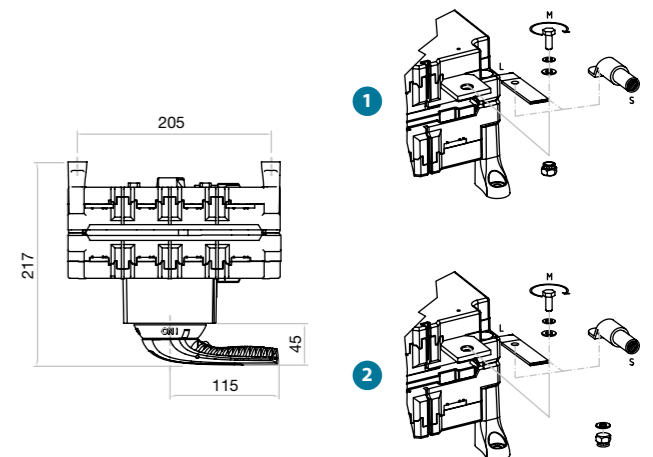
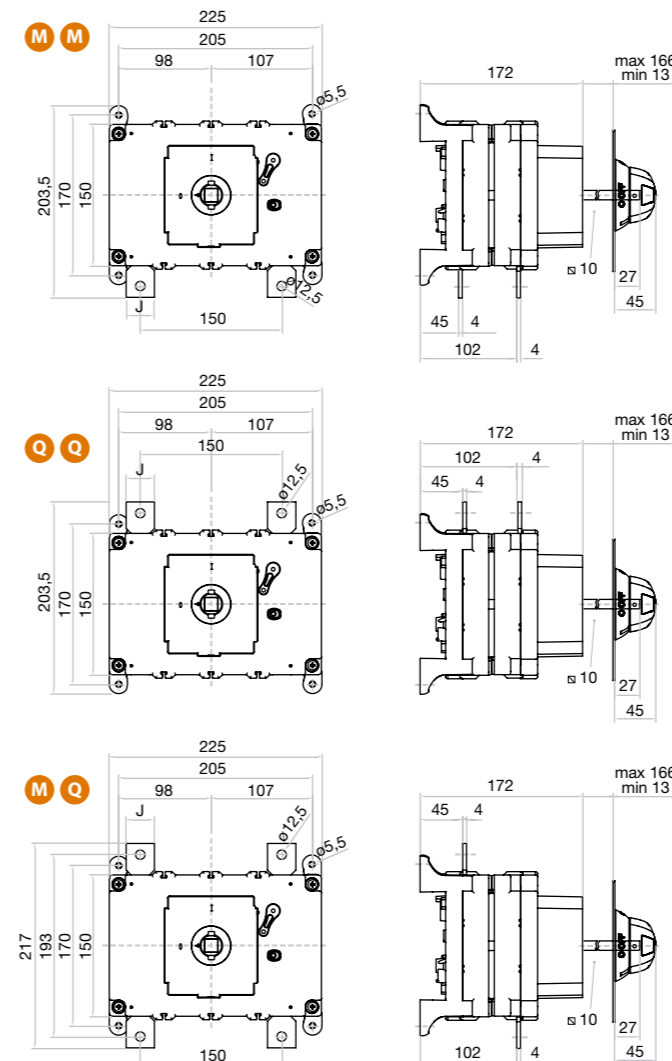
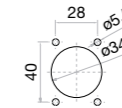

	J	S max (Cu) mm ²	H max (Cu) mm	L max (Cu) mm	T	M
					Nxm	
315 A	25	185	7	25	M10	18
400 A	30	240	7	35	M10	18

Table with multiple columns for Code and Page. It lists various electrical components such as DS-LI12, DS-LI21, DS-LI22, etc., along with their corresponding page numbers in a grid format.

You will find references of accessories that being common, they may appear on several pages of this catalogue. The references with the DC indication, belong to the products for Direct Current.

Utilization categories

Utilization categories according to IEC/EN 60947-3			
Nature of current	Utilization category		Typical applications
	Category A ^{*(2)}	Category B ^{*(3)}	
AC	AC-20A ^{*(1)}	AC-20B ^{*(1)}	Connecting and disconnecting under no-load conditions
	AC-21A	AC-21B	Switching of resistive loads including moderate overloads
	AC-22A	AC-22B	Switching of mixed resistive and inductive loads, including moderate overloads
	AC-23A	AC-23B	Switching of motor loads or other highly inductive loads
DC	DC-20A ^{*(1)}	DC-20B ^{*(1)}	Connecting and disconnecting under no-load conditions
	DC-21A	DC-21B	Switching of resistive loads including moderate overloads
	DC-22A	DC-22B	Switching of mixed resistive and inductive loads, including moderate overloads (e.g.: motores shunt)
	DC-23A	DC-23B	Switching of highly inductive loads (e.g. series motors)

^{*(1)} The use of these utilization categories is not permitted in the EE.UU.
^{*(2)} **A** Repeatedly operation
^{*(3)} **B** Not very repeatedly operation

Category AC-23 includes occasional switching of individual motors. The switching of capacitors or of tungsten filament lamps shall be subject to agreement between manufacturer and user.

The utilization categories referred do not apply to an equipment normally used to start, accelerate and /or stop individual motors. The utilization categories for such equipment are explained next:

Utilization category	Typical applications	
AC	AC-2	Slip-ring motors: starting, plugging ^{a)} , switching off
	AC-3	Squirrel-cage motors: starting, switching off of motors during running
	AC-4	Squirrel-cage motors: starting, plugging ^{a)} , inching ^{b)}
DC	DC-3	Shunt motors: starting, plugging ^{a)} , inching ^{b)} , dynamic breaking of d.c. motors
	DC-5	Serie-motors: starting, plugging ^{a)} , inching ^{b)} , dynamic breaking of d.c. motors

NOTE - The switching of motor circuits, capacitors or tungsten filament lamps shall be subject to special agreement between manufacturer and user.
^{a)} Plugging means stopping or reversing the motor rapidly by reversing motor primary connections while the motor is running.
^{b)} Inching (jogging) means energizing a motor once or repeatedly for short periods to obtain small movements of the driven mechanism.

» MAINTENANCE RECOMMENDATIONS:

Electrical installations and their components should be periodically checked to be in good working condition and manoeuvrability, be detected possible damage after accidents or wear by use or ageing. The condition of electrical connections should be checked, as the vibrations produced by circulating electricity loosens them over time and affects the performance and durability of the components as well as the equipment itself.

Neglecting this may not only damage or break components, systems and machinery, but can also cause accidents and injury to persons.

Before working on equipment or components which may be electrically live, the appropriate safety precautions should be taken (for operators, users and the public) by using personal protective equipment (e.g. appropriate work clothes, goggles, helmet, gloves and insulating footwear) and using the appropriate tools for the job; as well as establishing measures to restrict the movements of other people (by using warning signs, barriers, mechanical locks or restricted access, for example). Prior to using these items, they should be checked to be in good condition and properly fit for purpose (e.g. clothes without wear or tear and properly insulated tools).

Electrical work should be performed on equipment and in an area which is not electrically live by duly qualified and authorised personnel following the applicable regulations in each case.

Telergon, S.A.U. reserves the right to modify the products herein illustrated without prior notice. Technical data and description in the catalogue are accurate at the printing date, but no liabilities for errors or omissions are accepted. No danger or hazard to health and safety will be caused when products are installed, maintained and used in applications for which it is designed, in accordance with "professional practices" and manufacturer's instructions.

Products supplied by TELERGON are warranted for a period of 2 years against any manufacturing defect. TELERGON's guarantee is limited to the repair or replacement of the defective goods in the shortest possible time. This warranty does not cover the abuse or improper use by the user according to the technical instructions included in the sale by TELERGON, according to the current legislation, or their tampering or misuse. This warranty does not reach in any way third parties, being only applicable to the Customer.

February 2016

© Telergon, S.A.U. all rights reserved
 Upgrades, changes or corrections to this document at www.telergon.com, until new edition of the same.

The previous information is only advisory, it does not replace the specifications of the standard which will be consulted for its exact knowledge.



TDM-CATGEN-I-022016
COD. 01002032

> **telergon**
g o r i a n t e a m

> Telergon, S.A.U.
Ctra. Castellón (Pol. La Cartuja)
ES-50720 La Cartuja Baja
Zaragoza / Spain

> Tel.: + 34 976 50 08 76
Fax: + 34 976 50 03 14

> E-mail: comercial@telergon.es
www.telergon.com